



506 WEST BERCKMAN STREET  
FRUITLAND PARK, FL 34731

PHONE: 352 360-6727  
FAX: 352 360-6652

<b>Board Members:</b> Al Goldberg, Chairman Daniel Dicus, Vice Chair Carlisle Burch Fred Collins Walter Birriel	<b>Others:</b> Greg Beliveau, LPG Tracy Kelley, CDD Kelly Turner, Administrative Assistant Sharon Williams, Probationary Administrative Assistant
--------------------------------------------------------------------------------------------------------------------------------	------------------------------------------------------------------------------------------------------------------------------------------------------------

---

**AGENDA**  
**PLANNING & ZONING BOARD**  
**NOVEMBER 19, 2020**  
**6:00PM**

---

- I. **INVOCATION AND PLEDGE OF ALLEGIANCE:**
- II. **ROLL CALL:**
- III. **MINUTES FROM PREVIOUS MEETING:** Approve regular Planning and Zoning Board meeting minutes from October 15, 2020.
- IV. **OLD BUSINESS:** None
- V. **NEW BUSINESS:**
  - A. First Baptist Church Village Park Campus Preliminary and Final Plat (Alternate Keys 3911258 & 1287863)

Preliminary and Final plat applications submitted by Kaye Jameson, Clymer, Farner & Barley, Inc., on behalf of Art Ayris, First Baptist Church of Leesburg. Proposed subdivision of existing parcel will facilitate future commercial development. The proposed development will have four (4) commercial lots ranging in size from approximately sixty thousand (60,000) to one hundred thousand (100,000) square feet. Tract A, as shown on the plat, will serve as the access easement for the three (3) lots located west of Village Park Drive. A separate access easement area is shown for lot four (4), located east of Village Park Drive. Individual site plan applications will be submitted for each commercial parcel at the time of development.
  - B. Walmart Variance (Alternate Key 1170605)

Variance application submitted by Mark Asplund, Senior Project Manager of Walmart East Stores LP, owner of subject parcel. Applicant has designated Engineer Leopoldo Ayala, CPH, Inc., as acting agent. The applicant is seeking a variance from the Design Standards, as found in Section 162.060 of the City of Fruitland Park Land Development Regulations. The requested variance, if approved, will allow for a reduction in the parking space size from 10' x 20' to 10' x 18'. Wal-Mart has elected to modify the current site configuration for the addition of a stand-alone Wal-Mart Liquor Store within the existing parking lot. Proposed parking space size would be consistent with existing parking spaces, as approved in the original construction plans.

**BOARD MEMBERS' COMMENTS:**

**PUBLIC COMMENTS:**

This section is reserved for members of the public to bring up matters of concern or opportunities for praise. Note: Pursuant to F.S. 286.0114 and the City of Fruitland Park's Public Participation Policy adopted by Resolution 2013-023, members of the public shall be given a reasonable opportunity to be heard on propositions before the Planning and Zoning Board. Pursuant to Resolution 2013-023, public comments are limited to three minutes.

**ADJOURNMENT:**



506 WEST BERCKMAN STREET  
FRUITLAND PARK, FL 34731

PHONE: 352 360-6727  
FAX: 352 360-6652

**Board Members:**

Al Goldberg, Chairman  
Daniel Dicus, Vice Chair  
Carlisle Burch  
Fred Collins  
Walter Birriel

**Others:** Greg Beliveau, LPG

Tracy Kelley, CDD  
Kelly Turner, Administrative Assistant

---

**MINUTES**  
**PLANNING & ZONING BOARD**  
**OCTOBER 15, 2020**  
**6:00PM**

---

- I. **INVOCATION AND PLEDGE OF ALLEGIANCE:** Meeting called to order at 6:01PM. Administrative Assistant Turner led the invocation and Pledge of Allegiance.
- II. **ROLL CALL:** Board members present with the exception of Board member Birriel. Present LPG Beliveau, CDD Kelley and Administrative Assistant Turner.
- III. **MINUTES FROM PREVIOUS MEETING:** Approve regular Planning and Zoning Board meeting minutes from October 15, 2020. Motion to approve by Board member Collins. Second by Board member Burch. Approved 4-0.
- IV. **OLD BUSINESS:** None
- V. **NEW BUSINESS:**

A. Fruitland Park Commons CPUD Application (Alt Key 1288088)

Annexation, Rezoning and Large Scale Comprehensive Plan Amendment (LSCPA) application submitted by John Rehak on behalf of Benchmark Development I, LLC. The initial application proposed rezoning from Lake County Agricultural (A) to City of Fruitland Park General Commercial (C-2). Per City Land Planner recommendation, applicant resubmitted application to reflect rezoning to Commercial Planned Unit Development (CPUD), to include a conceptual plan. Applicant proposes LSCPA to designate the property Commercial-High Intensity to allow for commercial development including restaurant, hotel and retail uses.

LPG Beliveau gave introduction to the development applications. Proposed development currently zoned Lake County Agricultural (A); application submitted to

annex into the City of Fruitland Park and rezone to Commercial Planned Unit Development (CPUD). Development applications submitted in order to utilize parcel for a shopping center. The applicant has two similar shopping centers in Lady Lake. There are three applications, annexation, rezoning, and large scale comprehensive plan amendment (LSCPA). The property is currently owned by Lake County School Board who has appointed Benchmark Development I, LLC, to act as their agent for development application submittals.

LPG reviewed annexation application and recommends approval, as proposed annexation is in compliance with City of Fruitland Park Land Development Regulations. Likewise LPG recommends approval on the proposed LCCPA. The only item that LPG has comments on is the rezoning application. The front setback shown on the plan is twenty-five (25) feet whereas fifty (50) feet is required. Applicant agreed to adhere to the fifty (50) foot setback. Landscaping will comply with adopted Land Development Regulations, therefore no variance is required. LPG recommends a change to the Master Development Agreement (MDA) to comply with the proposed Comprehensive Plan Amendment. LPG Beliveau recommended a change to the verbiage outlined on page two; item "w" added to allow for a twenty (20) percent deviation from the conceptual plan without having to amend the Planned Unit Development (PUD) or Comprehensive Plan policy. The adopted Future Land Use (FLU) element already allows for a twenty (20) percent deviation, so adding this clause is recommended to comply with the transportation matrix, as long as the transportation maximums from the transportation study are not exceeded.

Board member Collins asked if the twenty (20) percent applies to the number of allowed hotel rooms. LPG clarified the concept plan shows 130 rooms, which may be increased by twenty (20) percent, so long as a decrease is made in another area.

LPG Beliveau clarified the required landscape buffer is twenty-five (25) feet while the required building setback is fifty (50) feet.

LPG Beliveau gave notification update; nineteen (19) mailings were sent to surrounding property owners, one (1) was returned opposed, zero (0) were returned unopposed and zero (0) were returned undeliverable.

LPG Beliveau stated access is being coordinated with Lake County Public Works Department. A future connection to Oliver Lane will be sought after. A dual boulevard is hopeful to the North.

City of Fruitland Park water and sewer are available to serve the development.

A full access median is proposed. No traffic light is proposed at this time. Future development may warrant a traffic signal.



Board member Dicus asked whether Benchmark Development I, LLC, has purchased the property from the Lake County School Board. LPG Beliveau responded the property is under contract pending development application approvals.

Martin DelleBovi in attendance on behalf of Benchmark Development I, LLC, and available to answer any questions. My. DelleBovi stated environmental assessments have been completed. There have been no impacts to subject property regarding a historic spill from a tank located on a neighboring property; property has been tested and cleared. Mr. DelleBovi is aware of environmental requirements regarding sand skinks. Benchmark Development I, LLC, will secure specific permit in the future; if the permit is issued forty-five (45) days prior to moving dirt, the permit will expire and a reapplication will be necessary. An environmental assessment report has been submitted and if the presence of sand skinks are found upon permitting, applicants understand the process of relocation.

Benchmark Development I, LLC, is the process of securing an access permit with Lake County Public Works Department.

Board member Dicus made motion to accept the annexation request as presented. Second by Board member Collins. Approved 4-0.

Board member Collins made motion to accept the rezoning request as presented. Second by Board member Burch. Approved 4-0.

Board member Collins made motion to repeal the previous vote in regards to the rezoning application. Second by Board member Dicus. Approved 4-0.

Board member Collins made motion to accept the rezoning as amended. Second by Board member Dicus. Approved 4-0.

Board member Dicus made motion to accept the Large Scale Comprehensive Plan Amendment as presented. Second by Board member Collins. Approved 4-0.

**BOARD MEMBERS' COMMENTS:** Chair Goldberg thanked Planning and Zoning Board members for their attendance.

**PUBLIC COMMENTS:** Carl Yauk, 1123 Ritter Road, The Villages, FL, questioned whether subject property is currently located within the City Limits of Fruitland Park. LPG Beliveau responded the item is on the agenda for annexation.

Mr. Yauk questioned whether applicant may develop the property if they do not incorporate into the City of Fruitland Park. LPG Beliveau responded the applicant may approach Lake County with

their request. Mr. Yauk questioned whether the applicant must be incorporated within the City of Fruitland Park to accomplish development request. LPG Beliveau responded Lake County would require the applicant to apply with the City of Fruitland Park for utility services. The City of Fruitland Park Commission could then decide whether the developer must annex into the City of Fruitland Park. Mr. Yauk questioned if the applicant could develop without incorporating into the City of Fruitland Park. LPG Beliveau responded they may attempt to develop without incorporating into the City of Fruitland Park.

Mr. Yauk questioned whether the development would generate liabilities to the City. Will there be additional costs to be incurred by the City for utilities? LPG Beliveau responded costs to connect are borne by the developer. Mr. Yauk questioned whether additional costs would be incurred by the City for Police and Fire services? LPG Beliveau stated city police and fire services are already provided in the area in which subject property is located. Mr. Yauk questioned the height of the proposed hotel. CDD Kelley responded the height of the hotel will be listed on the Site Plan application. Mr. Yauk questioned if additional fire equipment is required to service the hotel, who incurs the cost of this equipment? LPG Beliveau responded another developer has previously been approved to develop five (5) and six (6) story buildings, contingent upon the purchase of fire equipment needed to service said buildings. Board member Collins stated the maximum hotel height in subject development agreement is forty-five (45) feet. LPG Beliveau stated the City currently has the equipment required to serve the proposed hotel.

Board Chair Goldberg announced the three minute allotment for public comments has been exceeded. LPG Beliveau stated additional comments may be directed to Tracy Kelley, Director, Community Development Department, during normal business hours.

Mr. DelleBovi stated fire department requirements must be met prior to building permit approval. If the proposed hotel exceeds proposed height, additional requirements would be levied at that time.

**ADJOURNMENT: 6:32PM**



**City of Fruitland Park, Florida**  
**Community Development Department**  
 506 W. Berckman St., Fruitland Park, Florida 34731  
 Tel: (352) 360-6727 Fax: (352) 360-6652  
 www.fruitlandpark.org

<i>Staff Use Only</i>	
Case No.:	_____
Fee Paid:	_____
Receipt No.:	_____

## Development Application

Contact Information:

Owner Name: FBCL PROPERTIES, INC.  
 Address: 220 N. 13TH STREET, LEESBURG, FL 34748  
 Phone: \_\_\_\_\_ Email: ARTAYRIS@FBCLEESBURG.ORG

Applicant Name: KAYE JAMESON, P.S.M. - CLYMER, FARNER & BARLEY, INC  
 Address: 4450 NE 83RD ROAD, WILDWOOD, FL 34785  
 Phone: \_\_\_\_\_ Email: KJAMESON@CFB-INC.COM

Engineer Name: CLYMER, FARNER, BARLEY, INC.  
 Address: 4450 NE 83RD RD., WILDWOOD, FL 34785  
 Phone: 352-748-3126 Email: KJAMESON@CFB-INC.COM

Property and Project Information:

**PROJECT NAME\*:** VILLAGE PARK COMMERCIAL SUBDIVISION

\*A project name is required for all submissions. Please choose a name representative of the project for ease of reference.

Property Address: \_\_\_\_\_  
 Parcel Number(s): ALT KEY # 1287863 & 3911258 Section: 05 Township: 19S Range 24E  
 Area of Property: 7.33 ACRES Nearest Intersection: VILLAGE PARK DRIVE & CR 466-A  
 Existing Zoning: PUD Existing Future Land Use Designation: \_\_\_\_\_  
 Proposed Zoning: N/A Proposed Future Land Use Designation: N/A

The property is presently used for: \_\_\_\_\_  
 The property is proposed to be used for: COMMERCIAL DEVELOPMENT  
 Do you currently have City Utilities? \_\_\_\_\_

Application Type:

- |                                          |                                                |                                                 |                                                |
|------------------------------------------|------------------------------------------------|-------------------------------------------------|------------------------------------------------|
| <input type="checkbox"/> Annexation      | <input type="checkbox"/> Comp Plan Amendment   | <input type="checkbox"/> Rezoning               | <input type="checkbox"/> Planned Development   |
| <input type="checkbox"/> Variance        | <input type="checkbox"/> Special Exception Use | <input type="checkbox"/> Conditional Use Permit | <input checked="" type="checkbox"/> Final Plat |
| <input type="checkbox"/> Minor Lot Split | <input type="checkbox"/> Preliminary Plan      | <input type="checkbox"/> Construction Plan      | <input type="checkbox"/> ROW/Plat Vacate       |
| <input type="checkbox"/> Site Plan       | <input type="checkbox"/> Minor Site Plan       | <input type="checkbox"/> Replat of Subdivision  |                                                |

Please describe your request in detail: \_\_\_\_\_

**Required Data, Documents, Forms & Fees**

Attached to this application is a list of **REQUIRED** data, documents and forms for each application type as well as the adopted fee schedule. These items must be included when submitting the application package. Failure to include the supporting data will deem your application package **INCOMPLETE** and will not be processed for review.

Printed Name: ART AYRIS

Signature: *Art Ayris* Date: 8-26-20

If application is being submitted by any person other than the legal owner(s) of the property, the applicant must have written authorization from the owner to submit application.

OWNER'S AFFIDAVIT

STATE OF FLORIDA

COUNTY OF LAKE

Before me the undersigned authority, personally appeared ART AYRIS

FIRST BAPTIST LEESBURG, who being by me first duly sworn on oath deposes and says:

1) That he/she is the fee-simple owner of the property legally described on attached page of this application.

2) That he/she desires FBCB | CFB to allow DEVELOPMENT  
APPLICATION TO BE PROCESSED FOR A

PRELIMINARY AND FINAL PLAT.  
3) That he/she has appointed KAYE JAMESON - Clymer, Farmer, Barkley to act as agent on his/her behalf to accomplish the above. The owner is required to complete the Applicant's Affidavit of this application if no agent is appointed to act on his/her behalf.

[Signature]  
Affiant (Owner's Signature)

State of Florida

County of LAKE

The Foregoing instrument was acknowledged before me this 24<sup>th</sup> day of AUGUST, 20 20,  
by ART A. AYRIS who is personally known to me or has produced  
\_\_\_\_\_ as identification and who did or did not take an oath

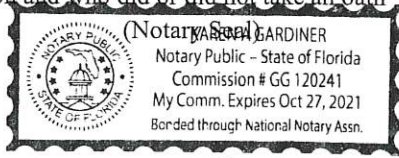

Notary Public - State of Florida  
Commission No GG 120241  
My Commission Expires 10-27-2021

[Signature]  
Signature  
KAREN A. GARDINER  
Printed Name

APPLICANT AFFIDAVIT

STATE OF FLORIDA

COUNTY OF LAKE

Before me the undersigned authority, personally appeared ART AYRIS  
FIRST BAPTIST WESBURG, who being by me first duly sworn on oath deposes and says:

- 1) That he/she affirms and certifies that he/she understandings and will comply with all ordinances, regulations, and provisions of the City of Fruitland Park, Florida, and that all statements and diagrams submitted herewith are true and accurate to the best of his/her knowledge and belief, and further that this application and attachments shall become part of the Official Records of the City of Fruitland Park, Florida, and are not returnable.
- 2) That the submittal requirements for the application have been completed and attached hereto as part of that application.
- 3) That he/she desires KAYE JAMES to allow DEVELOPMENT APPLICATION TO BE PROCESSED FOR A PRELIMINARY AND FINAL PLAT.

[Signature]  
Affiant (Applicant's Signature)

State of Florida  
County of LAKE

The Foregoing instrument was acknowledged before me this 24<sup>th</sup> day of AUGUST, 2020,  
by ART A. AYRIS who is personally known to me or has produced  
\_\_\_\_\_ as identification and who did or did not take an oath

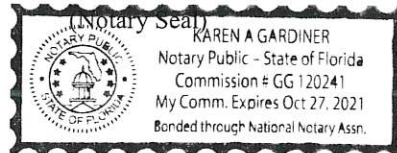

Notary Public - State of Florida  
Commission No GG120241  
My Commission Expires 10-27-2021

[Signature]  
Signature  
KAREN A. GARDINER  
Printed Name

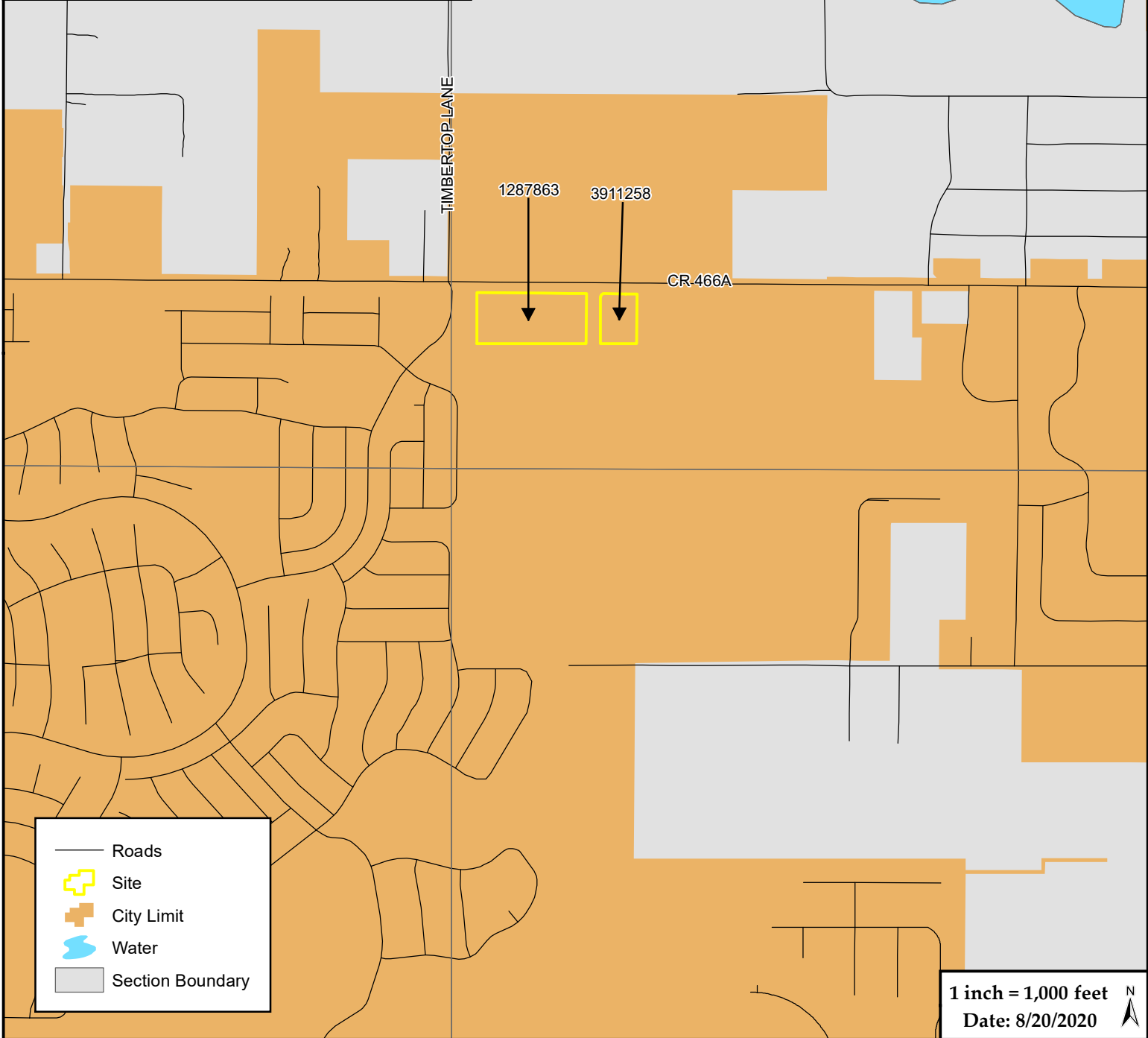
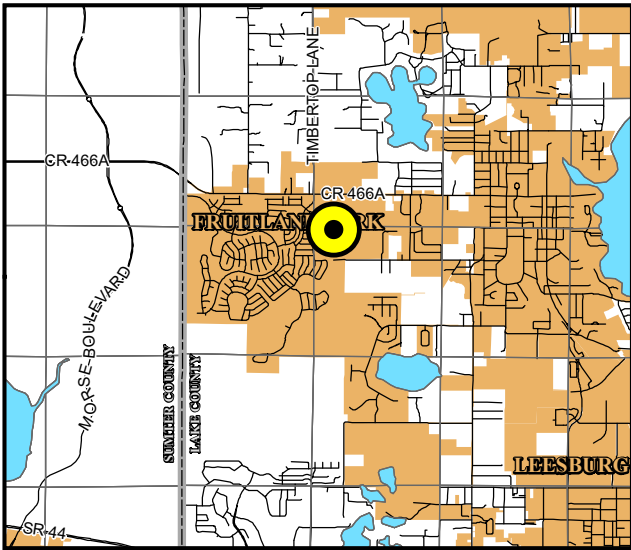

	Roads
	Site
	City Limit
	Water
	Section Boundary

1 inch = 1,000 feet  
 Date: 8/20/2020



Document Path: A:\8 Submittals\ Village Park Center\ Village Park Center - Location.mxd



Sections 05, 07, 08, 17, 18  
 Township 19S  
 Range 23E

### Location Map

**Village Park Center  
 Fruitland Park, FL**



**1<sup>ST</sup> REVISED DEVELOPMENT REVIEW LETTER  
FIRST BAPTIST CHURCH VILLAGE PARK CAMPUS  
PRELIMINARY AND FINAL PLAT APPLICATION  
NOVEMBER 5, 2020**

**Property Owner(s):** FBCL Properties, INC.  
**Applicant/Agent:** Kaye Jameson, P.S.M., Clymer Farner Barley, INC.  
**Phone:** (352) 748-3126  
**Email:** [kjameson@cfb-inc.com](mailto:kjameson@cfb-inc.com)  
**Address:** 4450 NE 83<sup>rd</sup> Rd  
Wildwood, FL 34785

**Project Name:** FBC Preliminary and Final Plat  
**Parcel IDs:** 05-19-24-0003-000-02200 & 05-19-24-0003-000-07400  
**Alt Keys:** 1287863 & 3911258  
**Project Addresses:**  
1000 Village Park Dr & Pine Ridge Dairy Rd  
Fruitland Park, FL 34731

Herein are the comments following the response to request for additional information number one (RAI #1), received October 22, 2020:

**City Attorney Review:**

1. In the Plat Dedication, No. 2 – please remove “subject to provisions and restrictions set forth in the Declaration.” The City’s utility easement cannot be subject to declarations that can be amended by the members upon a vote.
2. In the Plat Dedication, move the paragraph that begins, “The Association is an existing Florida corporation...” under Notes. It is confusing to have located in the dedication and the Association is not currently an owner of any of the property; therefore, not a signatory.
3. In Certificate of Surveyor the applicant included reference to Chapter 157 as requested; however, please insert after Chapter 157 “, LDRs”.

**City Engineer (BESH) Review:**

It appears Chapter 177 requirements have been met. See attached plat checklist.

**City Land Planner Review:**

Final concurrency analysis required at time of site plan approval of commercial lots.

**City Building Review:**

No comments.

**\*See response to RAI # 2, received 11/12/20 KT**

**City Code Enforcement Review:**

No comments.

**City Fire Review:**

No additional comments received following response to RAI #1 submittal.

**City Police Review:**

No comments received at time of review.

**City Public Works Department Review:**

No comments.

**City Staff Review:**

Request for additional information #2 to be satisfied prior to scheduled Planning and Zoning Board meeting.

**City of Leesburg Utilities Review:**

No additional comments received following response to RAI #1 submittal.

**Lake County Public Schools Review:**

No comments.

**Lake County Public Works Review:**

No additional comments received following response to RAI #1 submittal.



**BESH HALFF, INC.**  
**902 N. Sinclair Avenue**  
**Tavares, Florida 32778**  
 352-343-8481-Office  
 352-343-8495-Fax

**PLAT REVIEW CHECK LIST-CITY OF FRUITLAND PARK**  
*with references to Florida Statute*

**PLAT NAME:** Village Park Commercial Subdivision – Second Review

**CHECKED BY:** JENNINGS E. GRIFFIN, PLS 4486

**DATE:** 11-05-20

CHAPTER 177, FLORIDA STATUTES, REQUIREMENTS

**Legend:**

**OK= Complies with chapter 177 F.S.**

**N/A=not applicable**

**NO=needs more information**

1. ORIGINAL DRAWING BLACK PERMANENT DRAWING INK ON FILM (0.003 INCHES MINIMUM THICKNESS). 177.091 (1)	NO	NOT ON MYLAR
2. SHEET SIZE – 24" X 36"; ½" MARGIN ON TOP, BOTTOM, & RIGHT; 3" LEFT MARGIN. <i>Per Lake County Code Chapter XIV Section 14.07 2.</i>	OK	
3. MAP BOOK _____ PAGE _____, UPPER RIGHT HAND CORNER, per clerk of court.	OK	
4. SHEET NO. _____ OF _____ 177.091 (3)	OK	
5. INDEX SHEET IF MULTIPLE PAGES WITH MATCHLINES. 177.091. (3)	N/A	
6. CLEARLY LABELED MATCHLINES TO SHOW WHERE SHEETS MATCH OR ADJOIN. 177.091 (3)	N/A	
7. STATED AND GRAPHIC SCALE. 177.091 (4)	OK	
8. SUFFICIENT SIZE LETTERING AND SCALE TO SHOW DETAIL. 177.091 (4)  <i>And Per Lake County Code Chapter XIV Section 14.07</i>	OK	

<p>9. PLAT NAME ON EACH SHEET (THE SAME SIZE AND TYPE OF LETTERING, INCLUDING THE WORDS "SECTION", "UNIT", "REPLAT", "AMENDED", ETC.). 177.091 (5) &amp; 177.051 (1)</p>	OK	
<p>10. NAME OF SURVEYOR OR SURVEY BUSINESS, STREET, AND MAILING ADDRESS ON EACH SHEET. 177.091 (5)</p>	OK	
<p>11. NORTH ARROW. 177.091 (6)</p>	OK	
<p>12. BEARING REFERENCE TO A WELL ESTABLISHED AND MONUMENTED LINE. 177.091 (6)</p>	OK	
<p>13. PERMANENT REFERENCE MONUMENTS AT EVERY CORNER WITH APPROPRIATE SYMBOL OR DESIGNATION (LB OR LS NUMBER PRIOR TO PLATTING. 177.091 (7)</p>	OK	
<p>14. PERMANENT CONTROL POINTS ON THE CENTERLINE OF R.O.W. WITH APPROPRIATE SYMBOL OR DESIGNATION (LB OR LS NUMBER) WITHIN 1 (ONE) YEAR OR BEFORE BOND EXPIRATION. 177.091 (8)</p>	N/A	
<p>15. MONUMENTS AT LOT CORNERS – BEFORE THE TRANSFER OF ANY LOT OR BOND EXPIRATION. 177.091 (9)</p>	OK	
<p>16. SECTION, TOWNSHIP, AND RANGE UNDER THE NAME OF THE PLAT WITH REPLATTING INFORMATION, IF ANY. 177.091 (10) &amp; 177.091 (17)</p>	OK	
<p>17. NAME OF THE CITY, TOWN, VILLAGE, COUNTY, AND STATE THAT THE LAND BEING PLATTED IS IN. 177.091 (10)</p>	OK	
<p>18. CAPTION (DESCRIPTION) MUST BE SO COMPLETE THAT FROM IT, WITHOUT REFERENCE TO THE PLAT, THE STARTING POINT AND BOUNDARY CAN BE DETERMINED. 177.091 (11)</p>	OK	

19. ADOPTION AND DEDICATION WITH NOTARY. 177.081 (2) & 177.091 (12)	OK	
20. CERTIFICATE OF APPROVAL AND ACCEPTANCE BY GOVERNING BODY. 177.071 & 177.091 (12)	OK	
21. CERTIFICATE OF CLERK. 177.091 (13)	OK	
22. SURVEYOR'S CERTIFICATE 177.091 (13)	OK	
23. SURVEYOR'S CERTIFICATE INCLUDES "THAT THE PLAT WAS PREPARED UNDER HIS OR HER DIRECTION AND SUPERVISION AND THAT THE PLAT COMPLIES WITH ALL OF THE SURVEY REQUIREMENTS OF CHAPTER 177, PART 1, PLATTING.". 177.061	OK	
24. PRINTED NAME OF THE SURVEYOR; LICENSE NUMBER; SURVEY BUSINESS NAME, IF ANY; LB NUMBER, IF ANY; AND ADDRESS UNDER THE SURVEYOR'S CERTIFICATE 177.061	OK	
25. CERTIFICATE OF REVIEW BY PROFESSIONAL SURVEYOR AND MAPPER. 177.081 (1)	OK	
26. SECTION LINES AND ¼ SECTION LINES. 177.091 (14)	OK	
27. POINT OF REFERENCE, IF ANY. 177.091 (14)	OK	
28. POINT OF BEGINNING. 177.091 (14)	OK	
29. BEARINGS AND DISTANCES AROUND BOUNDARY. 177.091 (14)	OK	
30. STREET NAMES. 177.091 (15)	OK	



31. R.O.W. WIDTHS. 177.091 (15)	OK	
32. WATERWAYS. 177.091 (15)	N/A	
33. LOCATION AND WIDTH OF PROPOSED EASEMENTS. 177.091 (16)	OK	
34. LOCATION AND WIDTH OF EXISTING EASEMENTS IDENTIFIED IN THE TITLE OPINION. 177.091 (16)	OK	
35. BEARINGS AND DISTANCES FOR NON CONCENTRIC OR NON PARALELL EASEMENTS. 177.091 (16)	OK	
36. IDENTIFY CONTIGUOUS PROPERTIES BY SUBDIVISION TITLE, PLAT BOOK AND PAGE OR IF UNPLATTED, SO STATE. 177.091 (17)	OK	
37. LOT AND BLOCK NUMBERS MUST BE PROGRESSIVE. 177.091 (18)	OK	
38. BEARINGS AND DISTANCES ON ALL TRACTS. 177.091 (19)	OK	
39. BEARINGS AND DISTANCES ON ALL LOTS. 177.091 (19)	OK	
40. BEARINGS AND DISTANCES ON ALL ROADS. 177.091 (19)	N/A	
41. IF LOT OR BOUNDARY IRREGULAR, A WITNESS LINE MUST BE SHOWN. 177.091 (19)	N/A	
42. CURVILINEAR LOTS – SHOW RADIUS, ARC, AND DELTA. 177.091 (20)	OK	
43. RADIAL LINES WILL BE SO DESIGNATED. 177.091 (20)	N/A	
44. BEARINGS OR ANGLES ON ALL LINES. 177.091 (21)	OK	

45. BEARINGS AND DISTANCES ON CENTERLINE STREETS. 177.091 (22)	N/A	
46. CURVED CENTERLINES SHOW ARC, DELTA, RADIUS, CHORD, AND CHORD BEARING. 177.091 (22)	N/A	
47. DESIGNATE PARK AND RECREATION PARCELS, IF ANY. 177.091 (23)	N/A	
48. INTERIOR EXCEPTED PARCELS, AS DESCRIBED IN THE CAPTION, MUST BE LABELED "NOT A PART OF THIS PLAT". 177.091 (24)	N/A	
49. SHOW PURPOSE OF ALL AREAS DEDICATED ON THE PLAT. 177.091 (25)	OK	
50. TABULAR DATA MUST APPEAR ON SHEET WHICH IT APPLIES. 177.091 (26)	OK	
51. "NOTICE: THIS PLAT, AS RECORDED IN ITS GRAPHIC FORM, IS THE OFFICIAL DEPICTION OF THE SUBDIVIDED LANDS DESCRIBED HEREIN AND WILL IN NO CIRCUMSTANCES BE SUPPLANTED IN AUTHORITY BY ANY OTHER GRAPHIC OR DIGITAL FORM OF THE PLAT. THERE MAY BE ADDITIONAL RESTRICTIONS THAT ARE NOT RECORDED ON THIS PLAT THAT MAY BE FOUND IN THE PUBLIC RECORDS OF THIS COUNTY." 177.091 (27)	OK	
52. EASEMENTS REFERENCED FOR CABLE TELEVISION USE. 177.091 (28)	OK	
53. LEGEND OF ALL SYMBOLIZED ABBREVIATIONS. 177.091 (29)	OK	
54. BOUNDARY SURVEY. 177.041	OK	

55. CHECK ACCESS TO PUBLIC OR DEDICATED RIGHT OF WAY. <i>Informational</i>	OK	
----------------------------------------------------------------------------------	----	--

**NOTES:**

**CITY OF FRUITLAND PARK  
CHAPTER 157 SUBDIVISIONS  
CHECKLIST**

**Legend:**

**OK= Complies with Chapter 157**

**N/A=not applicable**

**NO=needs more information**

**CITY= For City use or does not apply to the Final plat**

20) Final Plat.

The approved final plat is the official record of the subdivision to be filed with the City Clerk and a copy shall be submitted to the Building Department. It is verification that the subdivided land has been developed substantially in accordance with the approved preliminary plat or that a bond has been posted which will secure the development as specified in the final plat, if applicable. The final plat must be approved by the City Commission and recorded in the Public Records of Lake County prior to the developer selling any lot or parcel.

A) Procedure. No final plat application shall be approved prior to the issuance of a land development permit. The plat shall be accompanied by: CITY

i) A complete final plat application furnished by the Building Department; CITY

ii) The appropriate filing fee and application; CITY

iii) Seven (7) copies of the final plat drawing showing the required information and certifications; CITY

iv) Security for maintenance of improvements meeting the requirements of the Land Development Code when a certificate of completion has been issued; CITY

v) A copy of the final protective covenants and deed restrictions, where such covenants and restrictions are required or established by the applicant; CITY

vi) All applicable informational requirements of the Land Development Code. CITY

vii) The City Manager or designee shall determine whether or not an application is complete and can be routed for interdepartmental review. No incomplete application shall be routed for review. CITY



viii) Current opinion of title prepared by a Florida attorney-at-law or title policy. OK

21) Format of Drawings. The final plat shall be:

- A) Prepared by a land surveyor registered and licensed in the State of Florida; OK
- B) On sheets twenty-four (24) inches by thirty-six (36) inches with one half inch margin on three sides and a three inch margin on the left side for binding; OK
- C) To a scale of no smaller than one inch represents one hundred (100) feet; OK
- D) Clearly drawn or printed with permanent black drawing ink; NO; NOT ON MYLAR
- E) On linen tracing cloth or stable base film a minimum of 0.003 inches thick coated upon completion with plastic material or a non-adhered scaled print on a stable base film made by photographic processes to ensure permanency; and NO: NOT ON MYLAR
- F) Printed with lettering no smaller than 1/8", with a commensurate letter-line width. CITY

23) Information Required. (All information as required in Chapter 177.091, F.S.). The final plat shall contain:

- A) A title block; OK
- B) The name of the proposed subdivision which shall not duplicate nor closely approximate the name of any other existing subdivision in the City. If the plat is an addition to an existing subdivision, it shall bear the same name as the existing subdivision; CITY
- C) The name of the city, county and state; OK
- D) The legal description; OK
- E) The date of preparation of the final plat and of any revisions; NO: NOT YET CERTIFIED
- F) A prominent "north arrow" on each sheet showing any portion of the subdivided lands; also, the reference bearing or azimuth in the notes or legend; OK
- G) The scale stated and graphically illustrated on each sheet; OK
- H) An index sheet on page one showing the entire subdivision and indexing the area shown on succeeding sheets. Each sheet must show the particular number of the sheet and the total number of sheets as well as clearly labeled match lines; OK



- I) The point of beginning shown together with the letters P.O.B. in bold letters when a point of beginning is used in the legal description; OK
- J) The initial point in the description shall be accurately tied to the nearest section corner, quarter section corner or government lot corner, and a certified corner record must be submitted to the Department of Natural Resources for such corner in accordance with Florida Statutes Section 177, part III; OK
- K) Boundary lines of the subdivided tract shown as a heavy line; OK
- L) All adjacent platted property identified by the subdivision name, plat book and page number; if not platted, so state; OK
- M) County and City limit lines within or abutting the tract; OK
- N) Permanent reference monuments and permanent control point locations as prescribed in Chapter 177, Florida Statutes, permanent reference monuments shall be installed prior to submission of final plat, permanent control points shall be installed within one year for the recording date; OK
- O) Survey data including all pertinent dimensions; OK
- P) Lot and block identification. Each lot and each block shall be identified; OK
- Q) Street names; OK
- R) The location and width of all existing or recorded streets intersecting or contiguous to the boundary of the plat; OK
- S) "Not included" parcels to be labeled "not a part of this plat"; N/A
- T) All easements including limited access easements shall be graphically depicted on the plat or included in the covenants and restrictions established by the applicant; CITY
- U) The following statements shall be noted on the plat in a prominent place:  
Notice: "There may be additional restrictions that are not recorded on this plat that may be found in the public records of Lake County"; OK
- V) A three inch by five inch space in the upper right hand corner of each sheet to be used by the Clerk of the Circuit Court for recording information. The following shall be depicted:  
PLAT BOOK: \_\_\_\_\_  
PAGE: \_\_\_\_\_ OK

W) The boundary of the final plat having a mathematical error of closure not greater than .01 foot. Any plat undertaking to establish a local tidal datum and determine the location of the mean high water line or mean low water line shall comply with the notification requirements of Florida Statutes Section 177.37. OK

23) Covenants, Restrictions, Reservations.

All covenants, restrictions or reservations placed by the developer or required by the City shall appear on the final plat or be established by separate recorded document, which documents shall be submitted to the City with the final plat. If done by separate document, the public record location of such documents shall be indicated beneath the subdivision name or in the margin as follows: "Covenants, restrictions, or reservations affecting the ownership or use of the property shown in this plat are filed in Official Record Book No. \_\_\_\_\_, page \_\_\_\_\_."  
CITY

24) Certification.

The final plat shall contain on the face or first page the following certifications, dedications and approvals, all executed and acknowledged as required by law, in the forms set forth below:

A) Dedications.

All areas reserved for use by the residents of the subdivision and all areas or facilities intended for public use, shall be specifically dedicated by the owner of the land at the time the plat is recorded. All streets, rights-of-way, easements, recreation facilities designed to serve more than one property owner shall be dedicated to the City, Community Development District or residents within the subdivision". The dedication to Community Development Districts and/or residents within the subdivision shall be dedicated without recourse to the City or any other public agency. All dedications shall be in the following forms or as approved by the City Attorney:

**CERTIFICATE OF DEDICATION**

**(Corporate)**

**STATE OF \_\_\_\_\_**

**COUNTY OF \_\_\_\_\_**

**KNOW ALL MEN BY THESE PRESENTS,** that (exact corporate name), a (state) corporation, fee simple owner of the land described and platted herein, as (exact name of subdivision), being in the City of Fruitland Park, Lake County, Florida, have caused said lands to be surveyed and platted as shown hereon and does hereby dedicate as follows: OK

**CERTIFICATE OF DEDICATION**

**(Individual)**

**STATE OF \_\_\_\_\_**

**COUNTY OF \_\_\_\_\_**

**KNOW ALL MEN BY THESE PRESENTS,** that (exact

owner's name), fee simple owner of the land described and platted herein, as (exact name of subdivision), being in the City of Fruitland Park, Lake County, Florida, has caused said lands to be surveyed and platted as shown hereon and does hereby dedicate as follows: N/A

**(SELECT AS APPROPRIATE):**

B) Streets and Right-of-ways. (For public streets)

All streets and rights-of-way shown on this plat (name specifically if less than all) are hereby dedicated in perpetuity to the City of Fruitland Park for the use and benefit of the public for proper purposes.

B) Streets and Right-of ways. (For public streets)

All streets and rights-of-ways shown on this plat (name specifically if less than all) are hereby dedicated in perpetuity to the City of Fruitland Park for the use and benefit of the public for proper purposes.

**i) Private Streets.**

All streets and rights-of-way shown on this plat (name specifically if less than all) are hereby declared to be and shall remain private. They are dedicated for the use and benefit of the owners and residents of this subdivision, and shall be of the perpetual maintenance obligation of the (state exact legal name of maintenance entity). All public authorities, including but not limited to police, fire, ambulance, and utility providers shall have the right to use the streets in the course of performing their respective duties. The City of Fruitland Park shall have no responsibility, duty or liability whatsoever regarding such streets. N/A

**ii) Utility Easements.**

The utility easements shown are reserved by the Developer for the construction, installation, maintenance and operation of utilities. CITY

**iii) Drainage and Stormwater Management Easements.**

The drainage easements and stormwater management tracts or easements as shown are reserved by the Developer or conveyed to a CDD or DD for construction, operation and maintenance of drainage facilities CITY

**iv) Park and Recreation Areas.**

The park and recreation areas are reserved by the Developer. N/A

**v) Limited Access Easements.**

The limited access easements as shown are reserved by the Developer or its assignees for the purposes of control and jurisdiction over access rights. N/A



vi) **Conservation Easements.**

Conservation easements as shown are dedicated to the appropriate agency for the purpose of preservation of environmentally sensitive areas. N/A

**(ADD APPROPRIATE CONCLUSION):**

**(Corporate)**

**IN WITNESS WHEREOF**, the above named corporation has caused these presents to be signed by its \_\_\_\_\_ and its corporate seal to be affixed hereto by and with the authority of its board of directors this \_\_\_\_\_ day of \_\_\_\_\_, \_\_\_\_\_.

**(FULL CORPORATE NAME)**, a corporation of the State of \_\_\_\_\_, By: \_\_\_\_\_ (Signature of president or vice president or chief executive

CITY (VERBIAGE HAS BEEN REVISED BY STATE)

**(Individual)**

**IN WITNESS WHEREOF**, (I) (we), (name(s)), have hereunto set (my) (our) hand(s) and seal(s) this \_\_\_\_\_ day of \_\_\_\_\_, \_\_\_\_\_.

WITNESSES:

\_\_\_\_\_  
(Typed Name) \_\_\_\_\_ (Signature)

N/A

(ADD ACKNOWLEDGEMENT OF THOSE EXECUTING THE DEDICATION)

25) Joinder and Consent to Dedication by Mortgagor or Other Party in Interest.

**MORTGAGOR'S CONSENT**

**STATE OF** \_\_\_\_\_  
**COUNTY OF** \_\_\_\_\_

The undersigned hereby certified that it is the holder of (a) mortgage(s), lien(s), or other encumbrance(s) upon the property described hereon and does hereby join in and consent to the dedication of the land described in said dedication by the owner thereof and agrees that its mortgage(s), lien(s) or other encumbrance(s) which (is) (are) recorded in Official Record Book \_\_\_\_\_ at page(s) \_\_\_\_\_ of the public records of Lake County, Florida, shall be subordinated to the dedication shown hereon.

IN WITNESS WHEREOF, (I) (we), \_\_\_\_\_ do hereunto set (my) (our) hand(s) and seal(s) this \_\_\_\_\_ day of \_\_\_\_\_, \_\_\_\_\_.

WITNESS

MORTGAGOR

\_\_\_\_\_ (Signature) \_\_\_\_\_ (Signature)

\_\_\_\_\_ (Typed name) \_\_\_\_\_ (Typed name)

N/A

**ADD ACKNOWLEDGMENT OF THOSE EXECUTING MORTGAGOR'S CONSENT**

**NOTE:** In accordance with Florida Statutes, Section 177.081, this joinder may be executed by a separate instrument joining in and ratifying the plat and all dedications thereon. If this means of joinder is used, such fact must be stated on the plat together with a reference to the location in the public records of such separate instrument.

N/A

26) Certificate of Title.

A title certification shall appear on the face or first page of each plat or may be submitted by a separate document, and shall state:

CITY

A) The lands as described and shown on the plat are in the name of, and apparent record title is held by, the person, persons, or organizations executing the dedication;

OK

B) That all taxes have been paid on said property as required by Section 197.192, Florida Statutes, as amended; and

OK

C) The official record book and page number of all mortgages, liens, or other encumbrances against the land, and the names of all persons holding an interest in such mortgage, lien or encumbrance.

CITY

The title certification shall be an opinion of a Florida attorney-at-law or the certification of an abstract or title insurance company licensed to do business in Florida. The City reserves the right to require that the title certification be brought current at the time of final plat approval.

OK

27) Certification of Surveyor. The plat shall contain:

A) The signature, registration number and official seal of the land surveyor certifying the survey data compiled and shown on the plat complies with all of the requirements of Chapter 177, Florida Statutes, as amended, chapter in the following forms:

NO (NOT YET SIGNED)

**CERTIFICATE OF SURVEYOR**

**KNOW ALL MEN BY THESE PRESENTS,** That the undersigned, being a licensed and registered land surveyor, does hereby certify that on \_\_\_\_\_ he completed the survey of the lands as shown in the foregoing plat; that said plat is a correct presentation of the lands therein described and platted or subdivided; that permanent reference monuments have been placed and each P.C.P. will be set as shown thereon within one year of the plat recording date as required by Chapter 177, Florida Statutes and Subdivisions and Platting, Chapter \_\_\_\_; and that said land is located in Fruitland Park, Florida.

Dated \_\_\_\_\_ Registration No. \_\_\_\_\_;  
OK

B) A statement that permanent reference monuments, "P.R.M.", have been set in compliance with Chapter 177, Florida Statutes, as amended; and OK

C) Each P.C.P. will be set under the direction and supervision of the surveyor within one year from the date the plat was recorded.  
N/A

28) Certificate of Approval by the City Commission.

The plat shall contain the approval and signature block for the City Commission and the acknowledgment and signature block of the Clerk of Circuit Court and the City Attorney. In the event the plat contains dedications to the City, this certificate shall also indicate whether the City accepts in whole or in part the dedications made. The following form is acceptable:

**CERTIFICATE OF APPROVAL BY CITY COMMISSION**

**THIS IS TO CERTIFY,** that on \_\_\_\_\_, the foregoing plat was approved by the City Commission of Fruitland Park, Florida. (Address acceptance of dedications in whole or in part, as appropriate).

\_\_\_\_\_  
Mayor  
Attest:

\_\_\_\_\_  
City Clerk

APPROVED AS TO FORM AND LEGAL SUFFICIENCY

\_\_\_\_\_  
City Attorney OK

29) Certificate of Approval by the Planning & Zoning Board.

The final plat shall contain the approval and signature of the Planning and Zoning Board Chairman in the following form:

**CERTIFICATE OF APPROVAL BY THE PLANNING AND ZONING BOARD**

Examined and Approved \_\_\_\_\_ Date \_\_\_\_\_  
OK

30) Clerk's Certification.

State of Florida  
County of Lake

I, Clerk of the Circuit Court of Lake County, Florida, do hereby certify that I have examined this plat of \_\_\_\_\_ subdivision and that it complies with all the requirements of

Chapter 177 of the Laws of Florida. This plat filed for record this \_\_\_\_ day of \_\_\_\_\_, \_\_\_\_\_, and recorded on Page \_\_\_\_ of Plat Book \_\_\_\_ in the office of the Clerk of Circuit Court of Lake County, Florida.

By: \_\_\_\_\_  
Clerk of Circuit Court, Lake County, Florida.  
OK

31) Instrument Prepared By.

The name and address of the Surveyor or Surveying Company who prepared the plat shall be contained on the plat. OK

32) Signatures.

All signatures required shall be originals on the final plat and shall be made in permanent black ink. NO (NOT YET SIGNED)

**NOTES:**

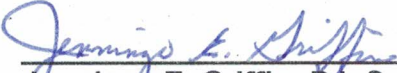
  
\_\_\_\_\_  
Jennings E. Griffin, P.L.S. #4486  
BESH HALFF, Inc.

C:



November 11, 2020

**Via Hand Delivery**

Ms. Kelly Turner  
Community Development Department  
City of Fruitland Park  
506 W. Berckman Street  
Fruitland Park, FL 34731

RE: **FBC Preliminary and Final Plat response to RAI # 2 SUBMITTAL**  
**(CFB # S19230.0000)**

Dear Ms. Turner:

Enclosed please find the following with regards to the above-referenced record plat submittal.

1. 1 signed mylar of the final plat.
2. One (1) cd with all documents.

**BESH HALFF, INC. comments- dated November 5, 2020**

1. Original drawing black permanent drawing ink on film (0.003 inches minimum thickness). 177.091 (1) (check list item 1) *Not on mylar yet*  
**Mylar is included with this submittal.**

**CITY OF FRUITLAND PARK CHAPTER 157 SUBDIVISIONS CHECKLIST COMMENTS**

- 21(D). Clearly drawn or printed with permanent black drawing ink; *Not on mylar yet.*  
**Mylar is included with this submittal.**
- 21(E). On linen tracing cloth or stable base film a minimum of 0.003 inches thick coated upon completion with plastic material or a non-adhered scaled print on a stable base film made by photographic processes to ensure permanency; *Not on mylar yet*  
**Mylar is included with this submittal.**
- 23(E). The date of preparation of the final plat and of any revisions: *Not yet certified.*  
**Final plat is included with this submittal.**
- 27 (A). Certification of Surveyor. The plat shall contain the signature, registration number and official seal of the land surveyor certifying the survey data, etc. *Not yet signed.*



**Signed mylar is included with this submittal.**

32. Signatures. All signatures required shall be originals on the final plat and shall be made in permanent black ink.  
*Not yet signed.*  
**Signed mylar is included with this submittal.**

**ANITA GERACI-CARVER, P.A. comments-**

**COMMENTS:**

1. In the Plat Dedication, No. 2 – please remove “subject to provisions and restrictions set forth in the Declaration.” The City’s utility easement cannot be subject to declarations that can be amended by members upon a vote.  
**This portion has now been removed as requested.**
2. In the Plat Dedication, move the paragraph that begins, (the Association is an existing Florida corporation...” under Notes. It is confusing to have located in the dedication and the Association is not currently an owner of any of the property, therefore, not a signatory.  
**This portion has been moved to the Notes as requested.**
3. In Certificate of Surveyor the applicate included reference to Chapter 157 as requested, however, please insert after Chapter 157 “,LDRs”.  
**This has been added as requested.**

Please contact us with the next available City Commission date.

Should you have any questions or need additional information, please contact our office.

Sincerely,

CLYMER, FARNER, BARLEY, INC.

  
Kaye M. Jameson, P.S.M.

KMJ/lc

encl.

cc: First Baptist Church

# BOUNDARY SURVEY

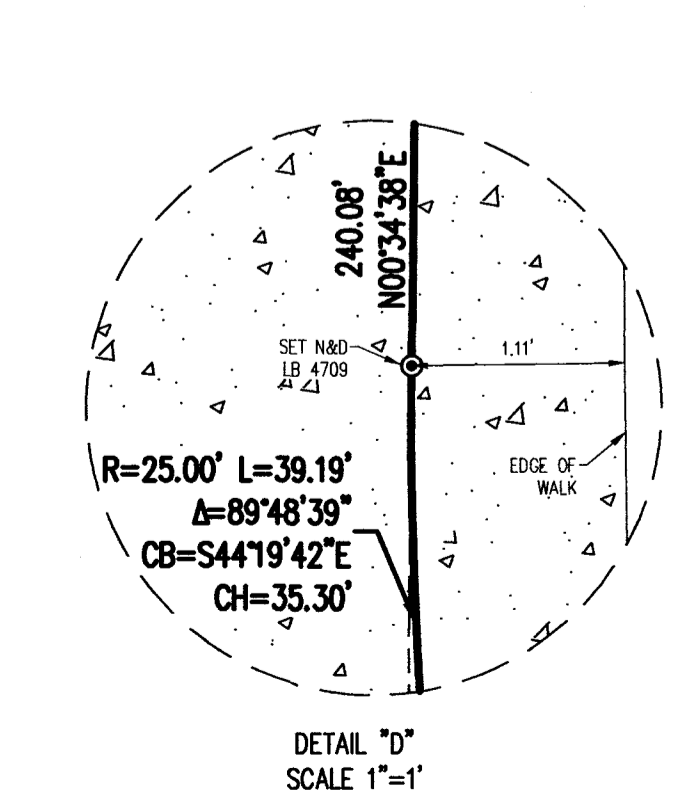
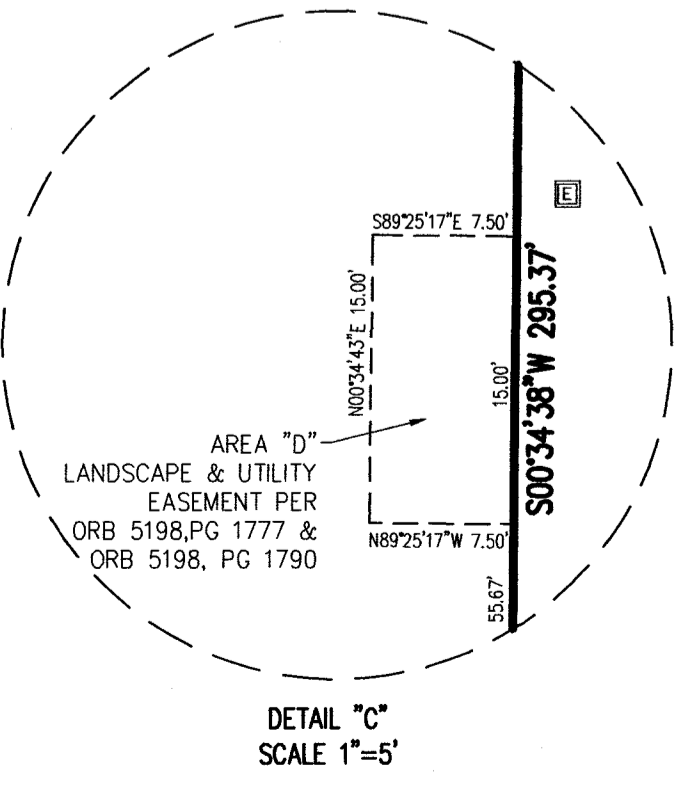
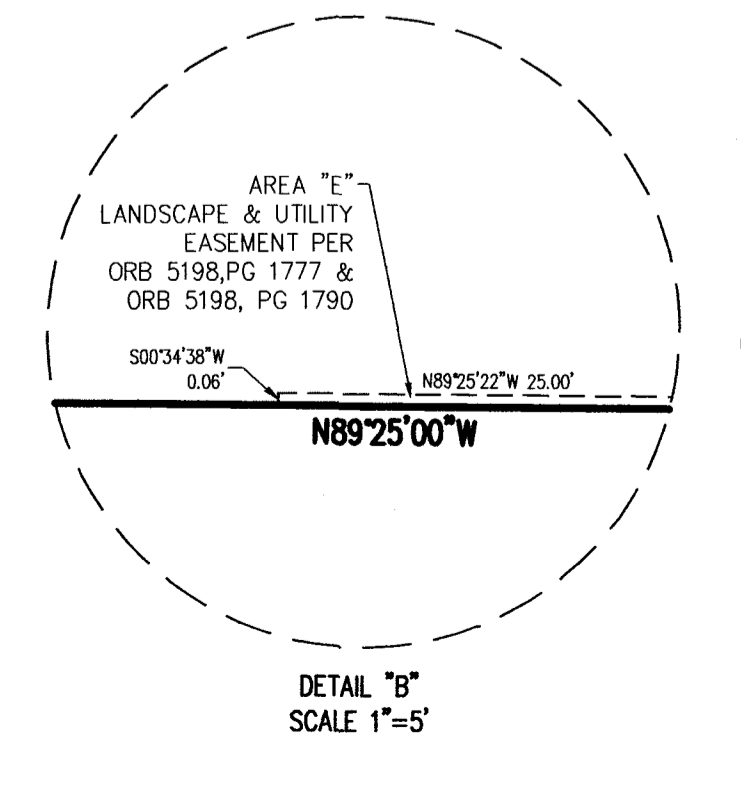
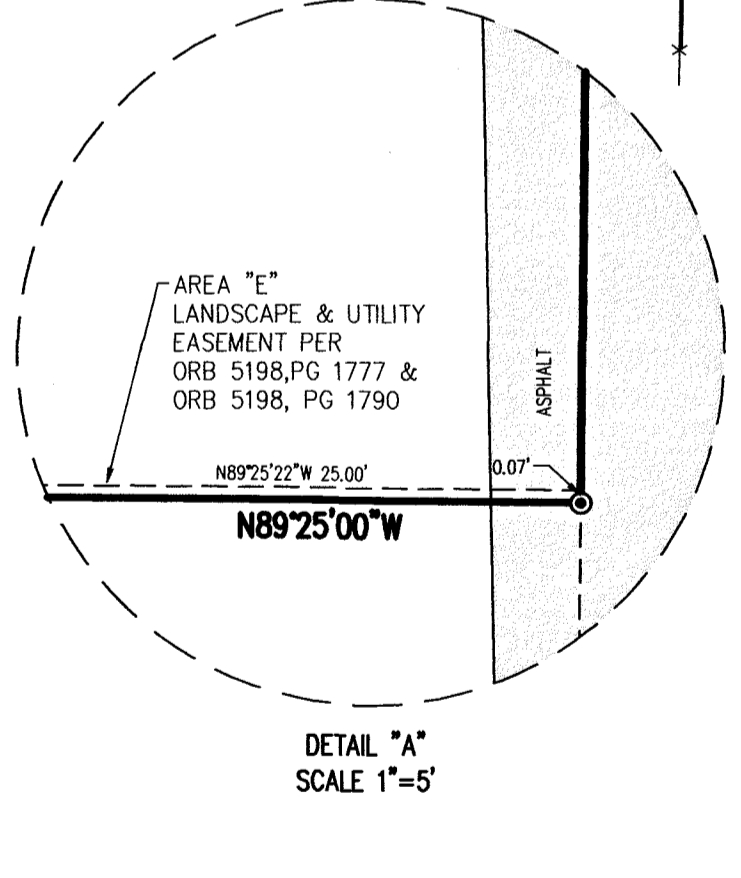
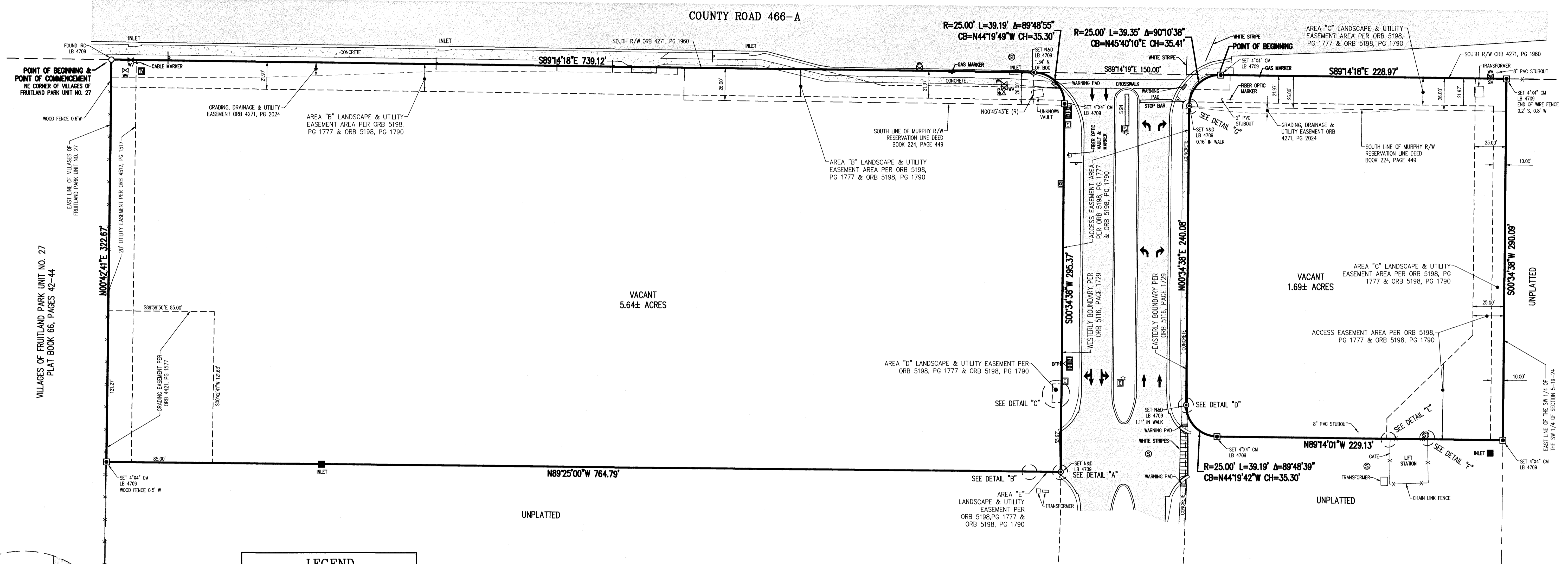
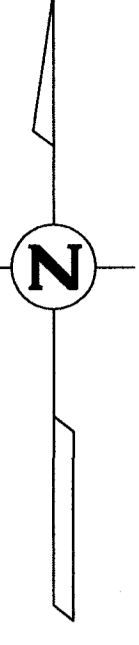
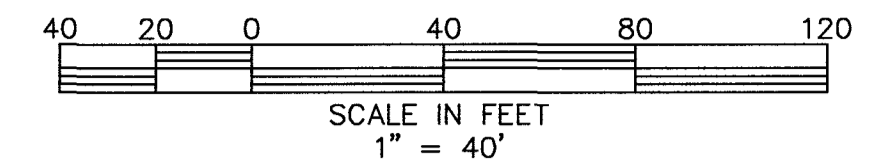

**LEGEND**

CM	INDICATES CONCRETE MONUMENT
NAD	INDICATES NAIL AND DISK
BC	INDICATES BACK OF CURB
IRC	INDICATES 5/8" IRON ROD AND CAP
PVC	INDICATES POLYVINYL CHLORIDE PIPE
PC	INDICATES PAGE
Δ	INDICATES DELTA (CENTRAL ANGLE OF CURVE)
CH	INDICATES ARC LENGTH
CL	INDICATES CHORD LENGTH
CB	INDICATES CHORD BEARING
R	INDICATES RADIUS LENGTH
PSM	INDICATES PROFESSIONAL SURVEYOR AND MAPPER
(R)	INDICATES RADIAL LINE
LB	INDICATES LICENSED BUSINESS
ORB	INDICATES OFFICIAL RECORD BOOK
R/W	INDICATES RIGHT-OF-WAY
SV	INDICATES SANITARY VALVE
WV	INDICATES WATER VALVE
BFP	INDICATES BACKFLOW PREVENTER
LP	INDICATES LIGHT POLE
ER	INDICATES ELECTRICAL RISER
SM	INDICATES SANITARY MANHOLE
STM	INDICATES STORM MANHOLE
SI	INDICATES SIGN
RTV	INDICATES CABLE TV RISER
ICB	INDICATES IRRIGATION CONTROL BOX

**LEGAL DESCRIPTION**

A PARCEL OF LAND LYING WITHIN SECTION 5, TOWNSHIP 19 SOUTH, RANGE 24 EAST, LAKE COUNTY, FLORIDA, DESCRIBED AS FOLLOWS:

BEGIN AT THE NORTHEAST CORNER OF VILLAGES OF FRUITLAND PARK UNIT NO. 27, ACCORDING TO THE PLAT THEREOF AS RECORDED IN PLAT BOOK 66, PAGES 42 THROUGH 44, PUBLIC RECORDS OF LAKE COUNTY, FLORIDA; SAID POINT ALSO BEING ON THE SOUTH RIGHT-OF-WAY LINE OF COUNTY ROAD 466-A PER OFFICIAL RECORDS BOOK 4271, PAGE 1960, PUBLIC RECORDS OF LAKE COUNTY, FLORIDA; THENCE ALONG SAID SOUTH RIGHT-OF-WAY LINE RUN S89°14'18"E A DISTANCE OF 739.12 FEET TO A POINT ON THE WESTERLY BOUNDARY OF LANDS DESCRIBED IN OFFICIAL RECORDS BOOK 5116, PAGE 1729, PUBLIC RECORDS OF LAKE COUNTY, FLORIDA; SAID POINT BEING ON A NON-TANGENT CURVE CONCAVE SOUTHWESTERLY AND HAVING A RADIUS OF 25.00 FEET, CHORD BEARING AND DISTANCE OF S44°19'42"E, 35.30 FEET TO WHICH A RADIAL LINE BEARS N00°45'43"E; THENCE ALONG SAID WESTERLY BOUNDARY WITH THE FOLLOWING TWO (2) COURSES: RUN SOUTHEASTERLY 39.19 FEET ALONG THE ARC THEREOF THROUGH A CENTRAL ANGLE OF 89°48'39" TO THE POINT OF TANGENCY; THENCE S00°34'38"W A DISTANCE OF 295.37 FEET; THENCE DEPARTING SAID WESTERLY BOUNDARY RUN N89°25'00"W A DISTANCE OF 764.79 FEET TO THE EAST BOUNDARY OF AFORESAID PLAT OF VILLAGES OF FRUITLAND PARK UNIT NO. 27; THENCE ALONG THE EAST BOUNDARY OF SAID PLAT RUN N00°42'41"E A DISTANCE OF 322.67 FEET TO THE POINT OF BEGINNING.

AND

A PARCEL OF LAND LYING WITHIN SECTION 5, TOWNSHIP 19 SOUTH, RANGE 24 EAST, LAKE COUNTY, FLORIDA, DESCRIBED AS FOLLOWS:

COMMENCE AT THE NORTHEAST CORNER OF VILLAGES OF FRUITLAND PARK UNIT NO. 27, ACCORDING TO THE PLAT THEREOF AS RECORDED IN PLAT BOOK 66, PAGES 42 THROUGH 44, PUBLIC RECORDS OF LAKE COUNTY, FLORIDA; SAID POINT ALSO BEING ON THE SOUTH RIGHT-OF-WAY LINE OF COUNTY ROAD 466-A PER OFFICIAL RECORDS BOOK 4271, PAGE 1960, PUBLIC RECORDS OF LAKE COUNTY, FLORIDA; THENCE ALONG SAID SOUTH RIGHT-OF-WAY LINE RUN S89°14'18"E A DISTANCE OF 889.12 FEET TO THE POINT OF BEGINNING; SAID POINT BEING ON THE EASTERLY BOUNDARY OF LANDS DESCRIBED IN OFFICIAL RECORDS BOOK 5116, PAGE 1729, PUBLIC RECORDS OF LAKE COUNTY, FLORIDA; THENCE CONTINUING ALONG SAID SOUTH RIGHT-OF-WAY LINE RUN S89°14'17"E A DISTANCE OF 228.97 FEET TO THE EAST LINE OF THE SOUTHWEST 1/4 OF THE SOUTHWEST 1/4 OF AFORESAID SECTION 5; THENCE DEPARTING SAID SOUTH RIGHT-OF-WAY LINE AND ALONG SAID EAST LINE RUN S00°34'38"W A DISTANCE OF 290.09 FEET; THENCE DEPARTING SAID EAST LINE RUN N89°14'01"W A DISTANCE OF 229.13 FEET TO THE POINT OF CURVATURE OF A CURVE CONCAVE NORTHEASTERLY AND HAVING A RADIUS OF 25.00 FEET; THENCE RUN NORTHWESTERLY 39.19 FEET ALONG THE ARC THEREOF THROUGH A CENTRAL ANGLE OF 89°48'39" TO THE POINT OF TANGENCY; SAID POINT BEING ON THE EASTERLY BOUNDARY OF LANDS DESCRIBED IN OFFICIAL RECORDS BOOK 5116, PAGE 1729, PUBLIC RECORDS OF LAKE COUNTY, FLORIDA; THENCE ALONG SAID EASTERLY BOUNDARY WITH THE FOLLOWING TWO (2) COURSES: RUN N00°34'38"E A DISTANCE OF 240.08 FEET TO THE POINT OF CURVATURE OF A CURVE CONCAVE SOUTHEASTERLY AND HAVING A RADIUS OF 25.00 FEET; THENCE RUN NORTHEASTERLY 39.35 FEET ALONG THE ARC THEREOF THROUGH A CENTRAL ANGLE OF 90°10'38" TO THE POINT OF BEGINNING.

CONTAINING 7.33 ACRES, MORE OR LESS.

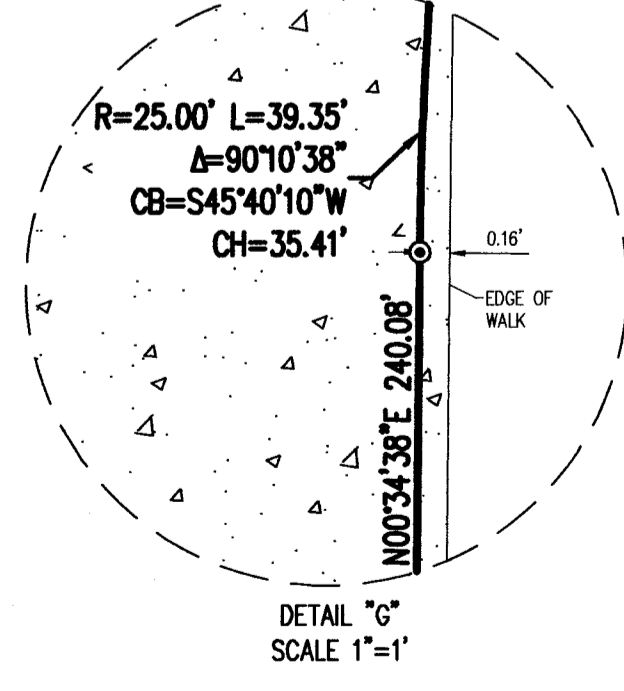
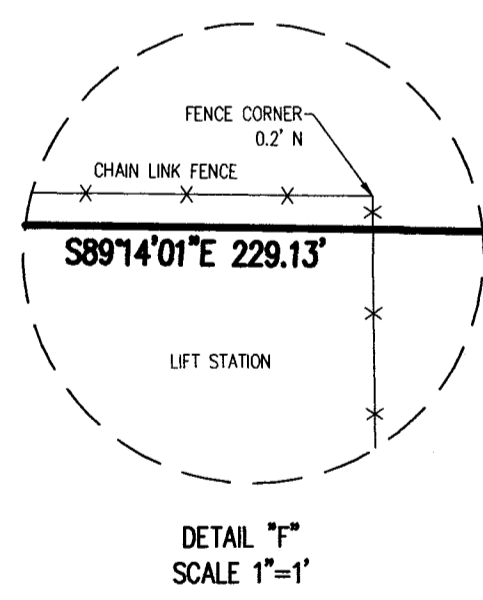
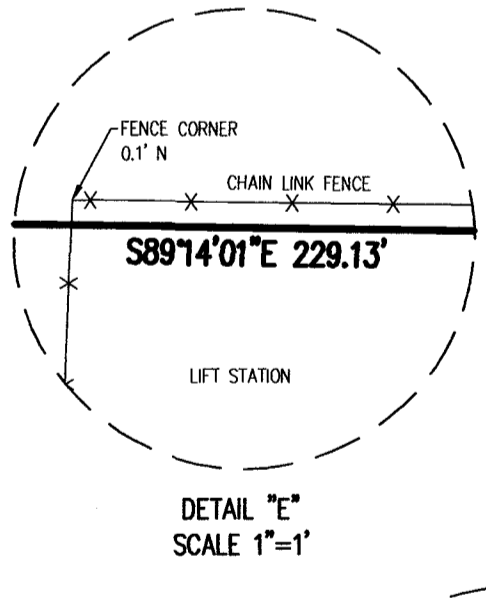

- NOTES:**
1. THE SURVEY MAP AND REPORT OR THE COPIES THEREOF ARE NOT VALID WITHOUT THE ORIGINAL SIGNATURE AND SEAL OF A FLORIDA LICENSED SURVEYOR AND MAPPER.
  2. CERTIFICATION IS LIMITED TO PARTIES NAMED HEREON.
  3. BEARINGS ARE BASED ON THE EAST LINE OF VILLAGES OF FRUITLAND PARK UNIT NO. 27 AS BEING N00°42'41"E, AN ASSUMED MERIDIAN.
  4. THE LEGAL DESCRIPTION WAS PREPARED BY THE SURVEYOR.
  5. LANDS SHOWN HEREON WERE NOT ABSTRACTED FOR EASEMENTS, RIGHTS OF WAY, OWNERSHIP OR OTHER MATTERS OF RECORD BY THIS FIRM.
  6. UNDERGROUND IMPROVEMENTS SUCH AS UTILITIES, FOUNDATIONS, ETC. WERE NOT LOCATED.
  7. LANDS SHOWN HEREON LIE IN FLOOD ZONE "X" (AREAS DETERMINED TO BE OUTSIDE OF THE 0.2% ANNUAL CHANCE FLOOD PLAIN) ACCORDING TO FLOOD INSURANCE RATE MAP COMMUNITY PANEL NUMBER 12069C 0308E, EFFECTIVE DATE: SEPTEMBER 18, 2012.
  8. THIS SURVEY MEETS ALL APPLICABLE REQUIREMENTS OF THE FLORIDA STANDARDS OF PRACTICE AS CONTAINED IN RULE 5J-17.052 OF THE FLORIDA ADMINISTRATIVE CODE.
  9. VISIBLE EASEMENTS OR ENCROACHMENTS (IF ANY) ARE SHOWN OR NOTED HEREON.

**CERTIFIED TO:**  
FIRST BAPTIST CHURCH OF LEESBURG

7/31/2020  
DATE

KAREM M. JAMESON, PROFESSIONAL SURVEYOR & MAPPER  
FLORIDA REGISTRATION NO. 5912

<b>SHEET 1 OF 1</b>		<b>BOUNDARY SURVEY</b>	
CLIENT	FIRST BAPTIST CHURCH OF LEESBURG	IN SECTION 5, TOWNSHIP 19 SOUTH, RANGE 24 EAST, LAKE COUNTY, FLORIDA.	
JOB NO.	S19230		
DATE	11/14/19	V19-64/2	
DRAWN BY	JH	CHECKED BY	KMJ
ACAD FILE	S19230 FBC COMMERCIAL BND.DWG	REVISIONS	DATE
4450 NE 83RD ROAD - MELBOURNE, FL 32951 - (321) 748-9129			

**RESOLUTION 2020-067**

**A RESOLUTION OF THE CITY COMMISSION OF THE CITY OF FRUITLAND PARK, FLORIDA, GRANTING FINAL PLAT APPROVAL FOR VILLAGE PARK COMMERCIAL SUBDIVISION GENERALLY LOCATED SOUTH OF 466A AND EAST OF MICRO RACETRACK ROAD; AND PROVIDING FOR AN EFFECTIVE DATE.**

**WHEREAS**, the applicant has petitioned for final plat approval of Village Park Commercial Subdivision; and

**WHEREAS**, Village Park Commercial Subdivision consists of 7.33 +/- acres that will consist of 4 commercial lots as well as Tract A an access and utility easement;

**WHEREAS**, the Planning and Zoning Board and the City Commission of the City of Fruitland Park have considered the application in accordance with the procedures for granting Final Plat Approval set forth in Section 157-060(d)(20) of the City of Fruitland Park Land Development Code;

**WHEREAS**, the Planning and Zoning Board recommended approval of the Final Plat;

**WHEREAS**, the City Commission finds that the Final Plat of Village Park Commercial Subdivision is in compliance with the City's land development regulations.

**NOW THEREFORE, BE IT RESOLVED BY THE CITY COMMISSION OF THE CITY OF FRUITLAND PARK, LAKE COUNTY, FLORIDA, AS FOLLOWS:**

**Section 1. Granting of Final Plat Approval.**

Approval of the Final Plat of Village Park Commercial Subdivision of consisting of 4 commercial lots and Tract A, an access and utility easement, **a copy of which is attached hereto**, is GRANTED.

**Section 2. Effective Date.**

This resolution shall become effective immediately upon its passage.

PASSED AND RESOLVED this \_\_\_\_ day of December 2020, by the City Commission of the City of Fruitland Park, Florida.

City of Fruitland Park

---

Chris Cheshire, Mayor

Attest:

Esther B. Coulson, City Clerk

---

Mayor Cheshire	_____	(Yes),	_____	(No),	_____	(Abstained),	_____	(Absent)
Vice Mayor Gunter	_____	(Yes),	_____	(No),	_____	(Abstained),	_____	(Absent)
Commissioner DeGrave	_____	(Yes),	_____	(No),	_____	(Abstained),	_____	(Absent)
Commissioner Mobilian	_____	(Yes),	_____	(No),	_____	(Abstained),	_____	(Absent)
Commissioner Bell	_____	(Yes),	_____	(No),	_____	(Abstained),	_____	(Absent)

Approved as to form and legality:

---

Anita Geraci-Carver, City Attorney



COVENANTS, RESTRICTIONS, OR RESERVATIONS AFFECTING THE OWNERSHIP OR USE OF THE PROPERTY SHOWN IN THIS PLAT ARE FILED IN OFFICIAL RECORDS BOOK PAGE

# VILLAGE PARK COMMERCIAL SUBDIVISION

SHEET 1 OF 2

PLAT BOOK

PAGE

BEING A PORTION OF SECTION 5, TOWNSHIP 19 SOUTH, RANGE 24 EAST, CITY OF FRUITLAND PARK, LAKE COUNTY, FLORIDA.

### LEGAL DESCRIPTION

A PARCEL OF LAND LYING WITHIN SECTION 5, TOWNSHIP 19 SOUTH, RANGE 24 EAST, LAKE COUNTY, FLORIDA, DESCRIBED AS FOLLOWS:

BEGIN AT THE NORTHEAST CORNER OF VILLAGES OF FRUITLAND PARK UNIT NO. 27, ACCORDING TO THE PLAT THEREOF AS RECORDED IN PLAT BOOK 66, PAGES 42 THROUGH 44, PUBLIC RECORDS OF LAKE COUNTY, FLORIDA; SAID POINT ALSO BEING ON THE SOUTH RIGHT-OF-WAY LINE OF COUNTY ROAD 466-A PER OFFICIAL RECORDS BOOK 4271, PAGE 1960, PUBLIC RECORDS OF LAKE COUNTY, FLORIDA; THENCE ALONG SAID SOUTH RIGHT-OF-WAY LINE RUN S89°14'18"E A DISTANCE OF 739.12 FEET TO A POINT ON THE WESTERLY BOUNDARY OF LANDS DESCRIBED IN OFFICIAL RECORDS BOOK 5116, PAGE 1729, PUBLIC RECORDS OF LAKE COUNTY, FLORIDA; SAID POINT BEING ON A NON-TANGENT CURVE CONCAVE SOUTHWESTERLY AND HAVING A RADIUS OF 25.00 FEET, CHORD BEARING AND DISTANCE OF S44°19'49"E, 35.30 FEET TO WHICH A RADIAL LINE BEARS N00°45'43"E; THENCE ALONG SAID WESTERLY BOUNDARY WITH THE FOLLOWING TWO (2) COURSES: RUN SOUTHEASTERLY 39.19 FEET ALONG THE ARC THEREOF THROUGH A CENTRAL ANGLE OF 89°48'55" TO THE POINT OF TANGENCY; THENCE S00°34'38"W A DISTANCE OF 295.37 FEET; THENCE DEPARTING SAID WESTERLY BOUNDARY RUN N89°25'00"W A DISTANCE OF 764.79 FEET TO THE EAST BOUNDARY OF AFORESAID PLAT OF VILLAGES OF FRUITLAND PARK UNIT NO. 27; THENCE ALONG THE EAST BOUNDARY OF SAID PLAT RUN N00°42'41"E A DISTANCE OF 322.67 FEET TO THE POINT OF BEGINNING.

AND

A PARCEL OF LAND LYING WITHIN SECTION 5, TOWNSHIP 19 SOUTH, RANGE 24 EAST, LAKE COUNTY, FLORIDA, DESCRIBED AS FOLLOWS:

COMMENCE AT THE NORTHEAST CORNER OF VILLAGES OF FRUITLAND PARK UNIT NO. 27, ACCORDING TO THE PLAT THEREOF AS RECORDED IN PLAT BOOK 66, PAGES 42 THROUGH 44, PUBLIC RECORDS OF LAKE COUNTY, FLORIDA; SAID POINT ALSO BEING ON THE SOUTH RIGHT-OF-WAY LINE OF COUNTY ROAD 466-A PER OFFICIAL RECORDS BOOK 4271, PAGE 1960, PUBLIC RECORDS OF LAKE COUNTY, FLORIDA; THENCE ALONG SAID SOUTH RIGHT-OF-WAY LINE RUN S89°14'18"E A DISTANCE OF 889.12 FEET TO THE POINT OF BEGINNING; SAID POINT BEING ON THE EASTERLY BOUNDARY OF LANDS DESCRIBED IN OFFICIAL RECORDS BOOK 5116, PAGE 1729, PUBLIC RECORDS OF LAKE COUNTY, FLORIDA; THENCE CONTINUING ALONG SAID SOUTH RIGHT-OF-WAY LINE RUN S89°14'18"E A DISTANCE OF 228.97 FEET TO THE EAST LINE OF THE SOUTHWEST 1/4 OF THE SOUTHWEST 1/4 OF AFORESAID SECTION 5; THENCE DEPARTING SAID SOUTH RIGHT-OF-WAY LINE AND ALONG SAID EAST LINE RUN S00°34'38"W A DISTANCE OF 290.09 FEET; THENCE DEPARTING SAID EAST LINE RUN N89°14'01"W A DISTANCE OF 229.13 FEET TO THE POINT OF CURVATURE OF A CURVE CONCAVE NORTHEASTERLY AND HAVING A RADIUS OF 25.00 FEET; THENCE RUN NORTHWESTERLY 39.19 FEET ALONG THE ARC THEREOF THROUGH A CENTRAL ANGLE OF 89°48'39" TO THE POINT OF TANGENCY; SAID POINT BEING ON THE EASTERLY BOUNDARY OF LANDS DESCRIBED IN OFFICIAL RECORDS BOOK 5116, PAGE 1729, PUBLIC RECORDS OF LAKE COUNTY, FLORIDA; THENCE ALONG SAID EASTERLY BOUNDARY WITH THE FOLLOWING TWO (2) COURSES: RUN N00°34'38"E A DISTANCE OF 240.08 FEET TO THE POINT OF CURVATURE OF A CURVE CONCAVE SOUTHEASTERLY AND HAVING A RADIUS OF 25.00 FEET; THENCE RUN NORTHEASTERLY 39.35 FEET ALONG THE ARC THEREOF THROUGH A CENTRAL ANGLE OF 90°10'38" TO THE POINT OF BEGINNING.

CONTAINING 7.33 ACRES, MORE OR LESS.

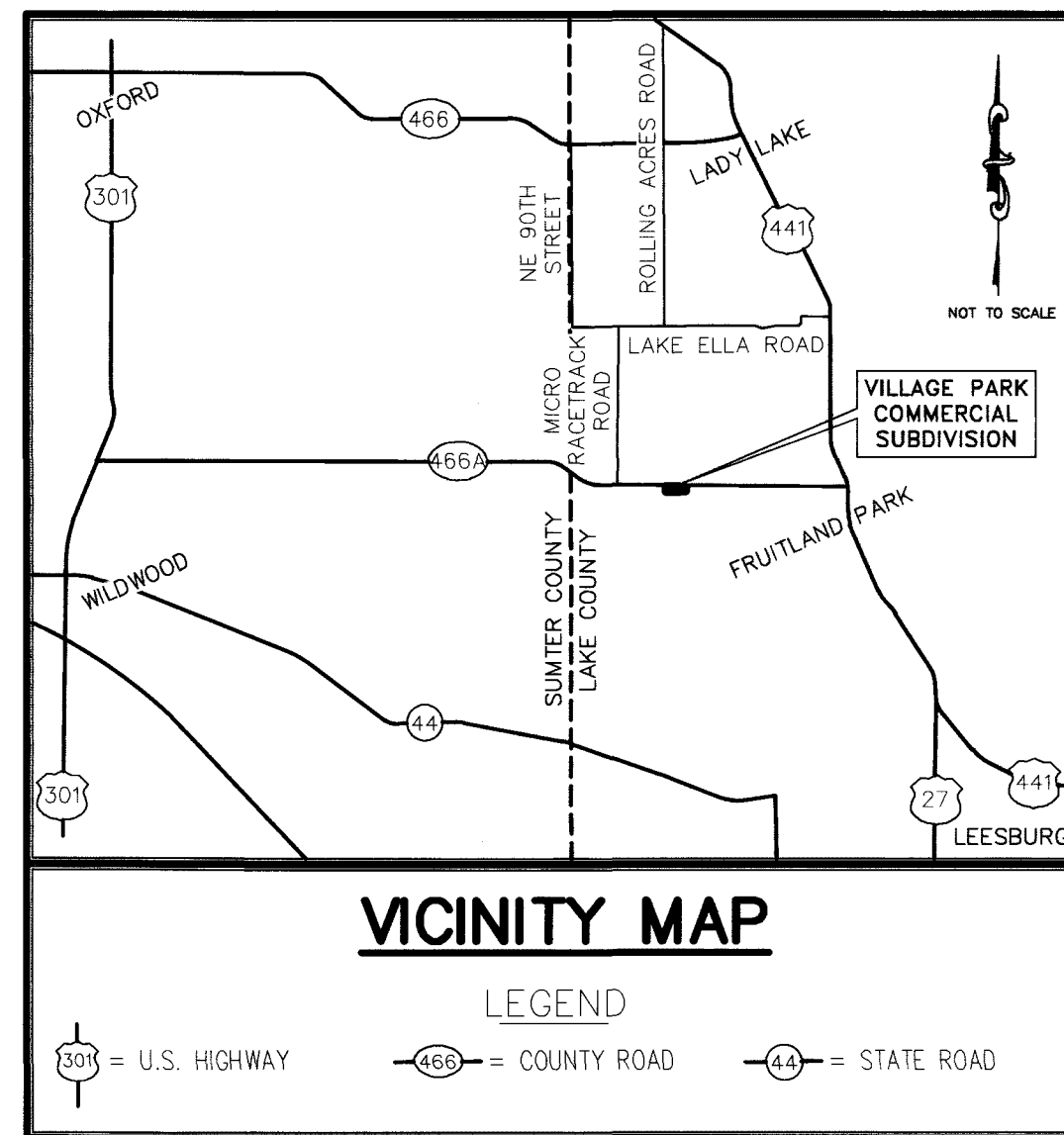

NOTICE: THIS PLAT, AS RECORDED IN ITS GRAPHIC FORM, IS THE OFFICIAL DEPICTION OF THE SUBDIVIDED LANDS DESCRIBED HEREIN AND WILL IN NO CIRCUMSTANCES BE SUPPLANTED IN AUTHORITY BY ANY OTHER GRAPHIC OR DIGITAL FORM OF THE PLAT. THERE MAY BE ADDITIONAL RESTRICTIONS THAT ARE NOT RECORDED ON THIS PLAT THAT MAY BE FOUND IN THE PUBLIC RECORDS OF THIS COUNTY.

NOTICE: NO CONSTRUCTION, TREES OR SHRUBS WILL BE PLACED IN EASEMENTS OR RIGHT-OF-WAY WITHOUT THE CITY OF FRUITLAND PARK APPROVAL.

### NOTES:

- BEARINGS ARE BASED ON AN ASSUMED MERIDIAN WITH THE EAST LINE OF THE SOUTHWEST 1/4 OF THE SOUTHWEST 1/4 OF SECTION 5, TOWNSHIP 19 SOUTH, RANGE 24 EAST AS BEING S00°34'38"W.
- ALL PLATTED UTILITY EASEMENTS SHALL ALSO BE EASEMENTS FOR THE CONSTRUCTION, INSTALLATION, MAINTENANCE, AND OPERATION OF CABLE TELEVISION SERVICES; PROVIDED, HOWEVER, NO SUCH CONSTRUCTION, INSTALLATION, MAINTENANCE, AND OPERATION OF CABLE TELEVISION SERVICES SHALL INTERFERE WITH THE FACILITIES AND SERVICES OF AN ELECTRIC, TELEPHONE, GAS, OR OTHER PUBLIC UTILITY. IN THE EVENT A CABLE TELEVISION COMPANY DAMAGES THE FACILITIES OF A PUBLIC UTILITY, IT SHALL BE SOLELY RESPONSIBLE FOR THE DAMAGES. THIS SECTION SHALL NOT APPLY TO THOSE PRIVATE EASEMENTS GRANTED TO OR OBTAINED BY A PARTICULAR ELECTRIC, TELEPHONE, GAS, OR OTHER PUBLIC UTILITY; SUCH CONSTRUCTION, INSTALLATION, MAINTENANCE, AND OPERATION SHALL COMPLY WITH THE NATIONAL ELECTRICAL SAFETY CODE AS ADOPTED BY THE FLORIDA PUBLIC SERVICE COMMISSION.
- ALL DISTANCES SHOWN ARE IN FEET.
- LOT CORNERS HAVE BEEN SET AT THE TIME OF RECORDING.
- ALL PERMANENT REFERENCE MONUMENTS (P.R.M.'S) HAVE BEEN SET IN ACCORDANCE WITH THE REQUIREMENTS OF CHAPTER 177, FLORIDA STATUTES.
- THE TITLE OPINION FOR THIS PLAT HAS BEEN SUBMITTED BY SEPARATE DOCUMENT.
- TRACT "A" IS FOR ACCESS AND UTILITIES AND WILL BE OWNED AND MAINTAINED BY THE VILLAGE PARK COMMERCIAL PROPERTY OWNERS ASSOCIATION, INC.
- TRACT "B" IS FOR ADDITIONAL RIGHT-OF-WAY AND WILL BE CONVEYED TO LAKE COUNTY, FLORIDA.
- PROPERTY IS SUBJECT TO AN EASEMENT IN FAVOR OF SUMTER ELECTRIC COOPERATIVE, INC. RECORDED IN O.R. BOOK 689, PAGE 1232 (BLANKET TYPE).
- THE ASSOCIATION IS AN EXISTING FLORIDA CORPORATION WHICH HAS BEEN FORMED IN ACCORDANCE WITH THE DECLARATION OF COVENANTS, CONDITIONS AND RESTRICTIONS APPLICABLE TO VILLAGE PARK COMMERCIAL SUBDIVISION. SAID INSTRUMENT, WHICH IS ENTITLED "DECLARATION OF COVENANTS, CONDITIONS AND RESTRICTIONS FOR VILLAGE PARK COMMERCIAL SUBDIVISION" (REFERRED TO IN THIS PLAT AS THE "DECLARATION"), SHALL BE RECORDED IN THE PUBLIC RECORDS OF LAKE COUNTY, FLORIDA IN CONNECTION WITH THE RECORDING OF THIS PLAT.

### DEDICATION VILLAGE PARK COMMERCIAL SUBDIVISION

STATE OF FLORIDA  
COUNTY OF LAKE

KNOW ALL MEN BY THESE PRESENTS, THAT FBCL PROPERTIES, INC., A FLORIDA CORPORATION, FEE SIMPLE OWNER OF THE LAND DESCRIBED AND PLATTED HEREIN AS VILLAGE PARK COMMERCIAL SUBDIVISION, BEING IN THE CITY OF FRUITLAND PARK, LAKE COUNTY, FLORIDA, HAS CAUSED SAID LANDS TO BE SURVEYED AND PLATTED AS SHOWN HEREON AND DOES HEREBY DEDICATE AS FOLLOWS SUBJECT TO THE GENERAL NOTES CONTAINED IN THIS PLAT:

1. TO VILLAGE PARK COMMERCIAL PROPERTY OWNERS ASSOCIATION, INC., A FLORIDA NOT-FOR-PROFIT CORPORATION (THE "ASSOCIATION"); TRACT "A", FOR THE PERPETUAL RIGHT OF INGRESS AND EGRESS BY THE OWNERS OF PROPERTY WITHIN VILLAGE PARK COMMERCIAL SUBDIVISION AND THEIR GUESTS, TENANTS, INVITEES AND LICENSEES, AND BY THE MEMBERS OF THE ASSOCIATION AND THEIR GUESTS, TENANTS, INVITEES AND LICENSEES, SUBJECT TO THE RIGHTS OF THE PROVIDERS OF UTILITIES AS DESCRIBED IN PARAGRAPH 2 BELOW AND THE RIGHTS OF THE PROVIDERS OF SANITATION, POSTAL, FIRE, LAW ENFORCEMENT AND EMERGENCY MEDICAL SERVICES AS DESCRIBED IN PARAGRAPH 3 BELOW.

2. TO THE CITY OF FRUITLAND PARK: A PERPETUAL UTILITY EASEMENT AS TO TRACT "A" FOR THE CONSTRUCTION, INSTALLATION, MAINTENANCE AND OPERATION OF UTILITIES BY ANY UTILITY PROVIDER.

3. TO THE PROVIDERS OF SANITATION, POSTAL, FIRE, LAW ENFORCEMENT AND EMERGENCY MEDICAL SERVICES, THEIR VEHICLES AND PERSONNEL: A PERPETUAL RIGHT OF INGRESS AND EGRESS AS TO TRACT "A", SUBJECT TO THE PROVISIONS AND RESTRICTIONS SET FORTH IN THE DECLARATION.

TRACT "B" IS DEDICATED TO THE PUBLIC.

IN WITNESS WHEREOF, THE ABOVE NAMED CORPORATION HAS CAUSED THESE PRESENTS TO BE SIGNED BY ITS PRESIDENT AND ITS CORPORATE SEAL TO BE AFFIXED HERETO BY AND WITH THE AUTHORITY OF ITS BOARD OF DIRECTORS THIS 11 DAY OF

November, 2020.

WITNESSES: OWNER:  
 (1) Lisa Carnes FBCL PROPERTIES, INC.,  
 SIGNATURE Lisa Carnes A FLORIDA CORPORATION  
 PRINT NAME Tom Spaman BY Tom Spaman  
 SIGNATURE Tom Spaman SIGNATURE  
 (2) Rechel Smith SIGNATURE  
 PRINT NAME Rechel Smith CORPORATE SEAL

STATE OF FLORIDA  
COUNTY OF LAKE

THE FOREGOING INSTRUMENT WAS ACKNOWLEDGED BEFORE ME, BY MEANS OF  PHYSICAL PRESENCE OR  ONLINE NOTARIZATION, THIS 11 DAY OF November, 2020, BY TOM SPAMAN THE PRESIDENT OF FBCL PROPERTIES, INC., A FLORIDA CORPORATION, ON BEHALF OF THE CORPORATION, FOR THE PURPOSES EXPRESSED HEREIN, WHO IS PERSONALLY KNOWN TO ME AND WHO DID NOT TAKE AN OATH.

Lisa Carnes  
 NOTARY PUBLIC - STATE OF FLORIDA  
 PRINT NAME: Lisa Carnes  
 COMMISSION NO.: GC 047770  
 COMMISSION EXPIRES: 11-15-20



### CERTIFICATE OF APPROVAL BY CITY COMMISSION

THIS IS TO CERTIFY THAT ON \_\_\_\_\_, 20\_\_\_\_, THE FOREGOING PLAT WAS APPROVED BY THE CITY COMMISSION OF FRUITLAND PARK, FLORIDA.

MAYOR \_\_\_\_\_  
 ATTEST: \_\_\_\_\_  
 CITY CLERK \_\_\_\_\_  
 APPROVED AS TO FORM AND LEGAL SUFFICIENCY \_\_\_\_\_  
 CITY ATTORNEY \_\_\_\_\_

### CERTIFICATE OF APPROVAL BY THE PLANNING AND ZONING BOARD

EXAMINED AND APPROVED \_\_\_\_\_ DATE \_\_\_\_\_

### CLERK'S CERTIFICATION

STATE OF FLORIDA  
COUNTY OF LAKE  
 I, CLERK OF THE CIRCUIT COURT OF LAKE COUNTY, FLORIDA, DO HEREBY CERTIFY THAT I HAVE EXAMINED THIS PLAT OF VILLAGE PARK AND THAT IT COMPLIES WITH ALL THE REQUIREMENTS OF CHAPTER 177 OF THE LAWS OF FLORIDA. THIS PLAT FILED FOR RECORD THIS DAY OF \_\_\_\_\_, 20\_\_\_\_, AND RECORDED ON PAGE \_\_\_\_\_ OF PLAT BOOK \_\_\_\_\_ IN THE OFFICE OF THE CLERK OF CIRCUIT COURT OF LAKE COUNTY, FLORIDA.

BY: \_\_\_\_\_  
 CLERK OF CIRCUIT COURT, LAKE COUNTY, FLORIDA.

### RECORD PLAT REVIEW STATEMENT

PURSUANT TO SECTION 177.081, FLORIDA STATUTES, I HEREBY CERTIFY THAT I HAVE PERFORMED A LIMITED REVIEW OF THIS PLAT FOR CONFORMITY TO CHAPTER 177, FLORIDA STATUTES AND THAT SAID PLAT COMPLIES WITH THE TECHNICAL REQUIREMENTS OF THAT CHAPTER; PROVIDED, HOWEVER, THAT MY REVIEW AND CERTIFICATION DOES NOT INCLUDE FIELD VERIFICATION OF ANY POINTS OR MEASUREMENTS SHOWN ON THIS PLAT.

SIGNATURE \_\_\_\_\_ DATE \_\_\_\_\_  
 PRINT NAME \_\_\_\_\_ REGISTRATION NO. \_\_\_\_\_

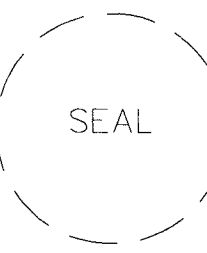
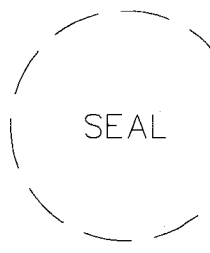
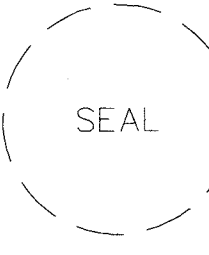

### CERTIFICATE OF SURVEYOR

KNOW ALL MEN BY THESE PRESENTS, THAT THE UNDERSIGNED, BEING A LICENSED AND REGISTERED LAND SURVEYOR, DOES HEREBY CERTIFY THAT ON Dec. 9, 2019 SHE COMPLETED THE SURVEY OF THE LANDS AS SHOWN IN THE FOREGOING PLAT; THAT SAID PLAT IS A CORRECT REPRESENTATION OF THE LANDS THEREIN DESCRIBED AND PLATTED OR SUBDIVIDED AND COMPLIES WITH ALL OF THE SURVEY REQUIREMENTS OF CHAPTER 177, PART 1 FLORIDA STATUTES; THAT PERMANENT REFERENCE MONUMENTS HAVE BEEN PLACED AND EACH P.C.P. (IF ANY) WILL BE SET AS SHOWN THEREON WITHIN ONE YEAR OF THE PLAT RECORDING DATE AS REQUIRED BY CHAPTER 177, PART 1 (PLATTING) FLORIDA STATUTES AND SUBDIVISIONS AND PLATTING, CHAPTER 157 LDR'S; AND THAT SAID LAND IS LOCATED IN FRUITLAND PARK, FLORIDA.

CLYMER FARNER BARLEY, INC.  
 4450 N.E. 83rd ROAD  
 WILDWOOD, FLORIDA 34785  
 LICENSED BUSINESS NO. 4709  
 BY: Kaye M. Jameson  
 REGISTRATION NO. 5912

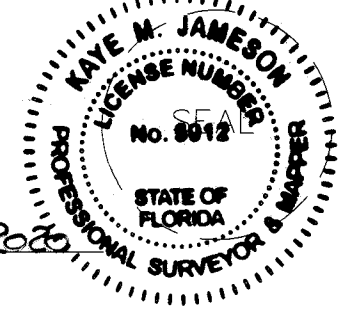

THIS INSTRUMENT PREPARED BY:  
 KAYE M. JAMESON, P.S.M. 5912

**CLYMER FARNER BARLEY**  
 CLYMER FARNER BARLEY, Inc.  
 4450 NE 83RD RD, WILDWOOD, FL 34785  
 (352) 748-3126  
 WWW.CFB-INC.COM CA #4709

# VILLAGE PARK COMMERCIAL SUBDIVISION

BEING A PORTION OF SECTION 5, TOWNSHIP 19 SOUTH, RANGE 24 EAST,  
CITY OF FRUITLAND PARK, LAKE COUNTY, FLORIDA.

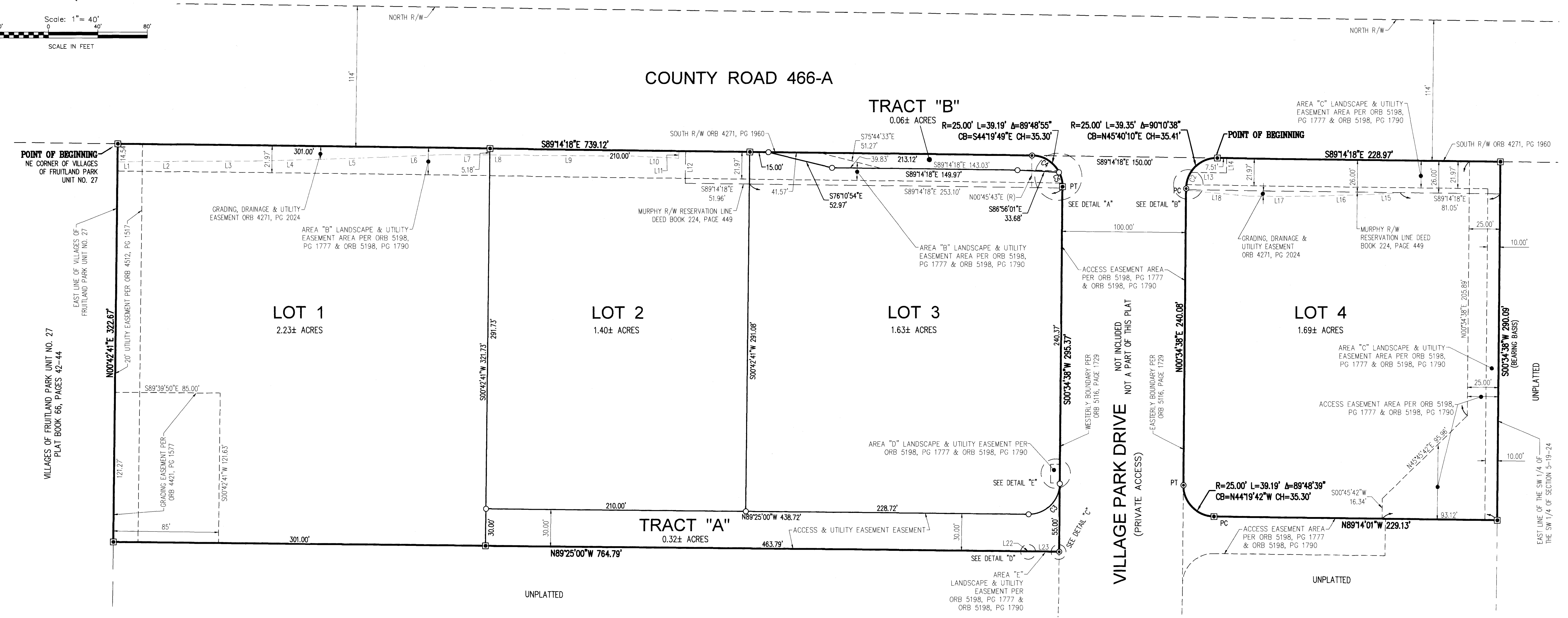
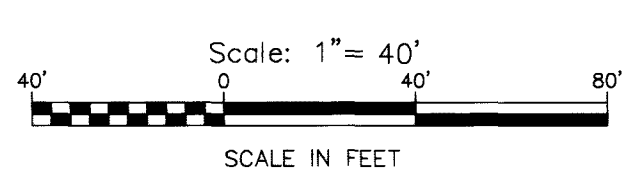

### LEGEND

- INDICATES 4" x 4" x 24" CONCRETE PERMANENT REFERENCE MONUMENT (P.P.M.) FOUND (LB #4709), UNLESS OTHERWISE NOTED.
- INDICATES 4" x 4" x 24" CONCRETE PERMANENT REFERENCE MONUMENT (P.P.M.) SET (LB #4709)
- INDICATES P.K. NAIL AND DISK PERMANENT REFERENCE MONUMENT (P.P.M.) LB #4709
- INDICATES 5/8" IRON PIN AND CAP TO BE SET IN ACCORDANCE WITH SECTION 177.091(9) FLORIDA STATUTES. (SEE NOTE #5)
- C9 INDICATES CURVE NUMBER IN CURVE TABLE
- L9 INDICATES LINE NUMBER IN LINE TABLE
- BNG. INDICATES BEARING
- INDICATES CENTERLINE
- INDICATES DELTA (CENTRAL ANGLE OF CURVE)
- CB INDICATES CHORD BEARING
- CH INDICATES CHORD DISTANCE
- L INDICATES ARC LENGTH
- LB INDICATES LICENSED BUSINESS
- NO. INDICATES NUMBER
- ORB INDICATES OFFICIAL RECORDS BOOK
- PB INDICATES PLAT BOOK
- PG INDICATES PAGE
- PGS INDICATES PAGES
- PC INDICATES POINT OF CURVATURE
- PCC INDICATES POINT OF COMPOUND CURVATURE
- PRC INDICATES POINT OF REVERSE CURVATURE
- PT INDICATES POINT OF TANGENCY
- R INDICATES RADIUS LENGTH
- SO FT INDICATES SQUARE FEET
- (R) INDICATES RADIAL LINE
- R/W INDICATES RIGHT-OF-WAY

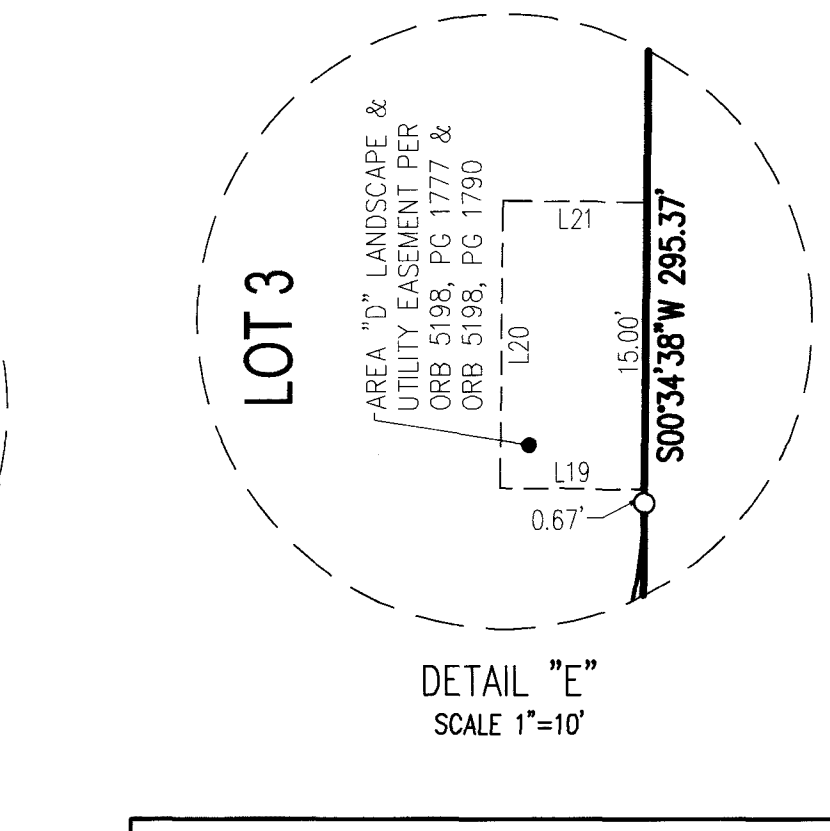
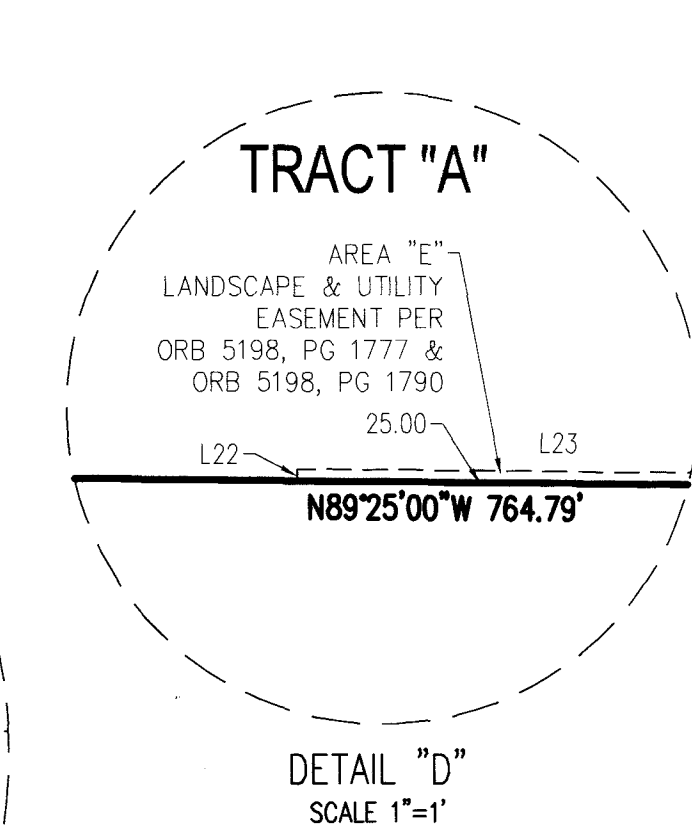
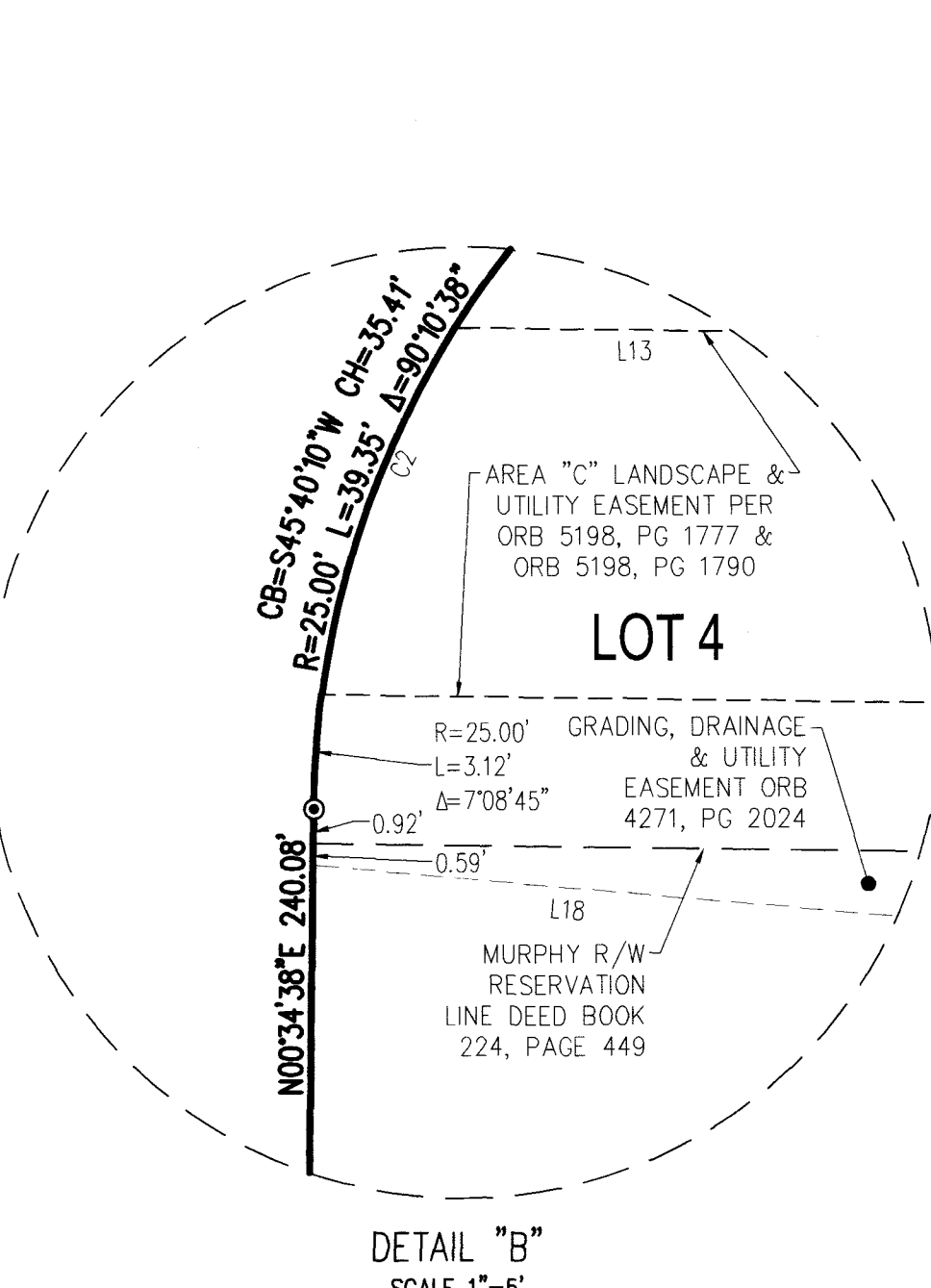
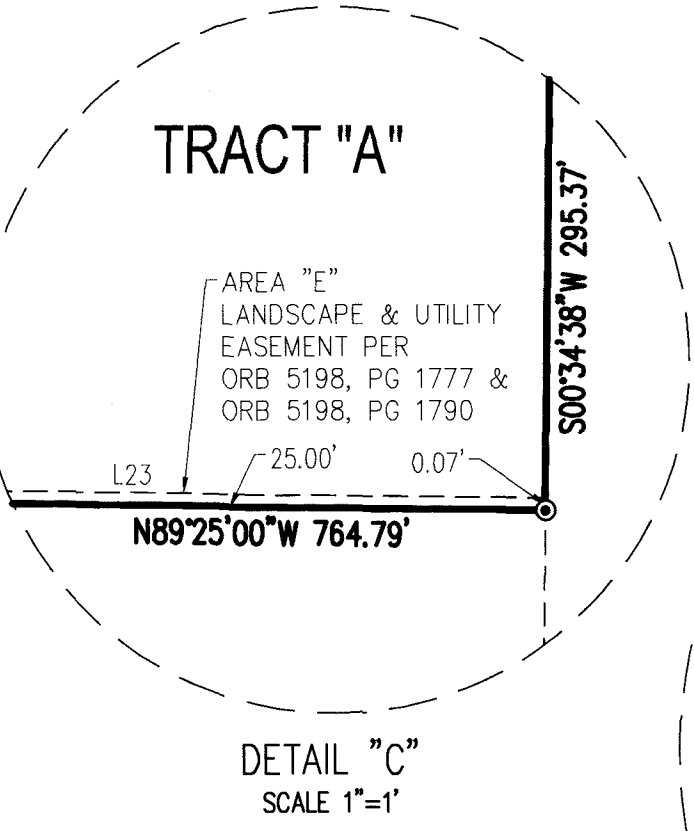
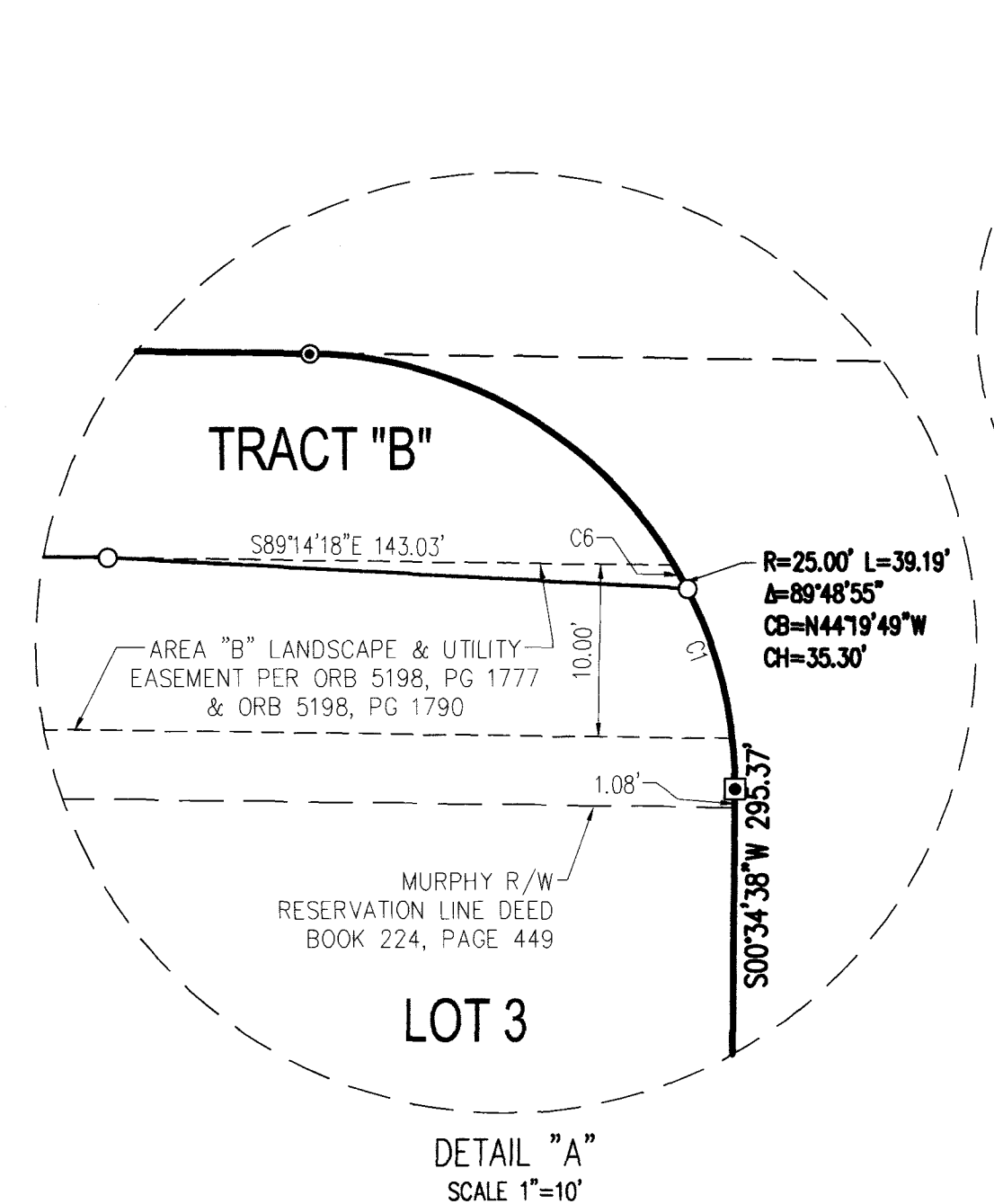

### CURVE TABLE

CURVE	LENGTH	RADIUS	DELTA	CHORD BNG.	CHORD
C1	9.11'	25.00'	20°52'51"	N16°38'47"W	9.06'
C2	10.67'	25.00'	24°27'07"	S19°57'09"W	10.59'
C3	39.27'	25.00'	90°00'22"	N45°34'49"E	35.36'
C4	27.12'	25.00'	62°08'55"	N58°09'50"W	25.81'
C5	12.07'	25.00'	27°40'00"	N13°15'22"W	11.95'
C6	1.56'	25.00'	3°34'17"	N28°52'22"W	1.56'

### LINE TABLE

LINE	LENGTH	BEARING
L1	14.49'	S89°00'57"W
L2	50.00'	S89°57'19"W
L3	50.01'	S89°48'22"W
L4	50.04'	S88°35'03"W
L5	50.06'	S88°00'15"W
L6	50.08'	S87°36'31"W
L7	36.51'	N89°43'45"W
L8	13.49'	N89°43'45"W
L9	100.00'	N89°36'32"W
L10	39.15'	N87°20'02"W
L11	5.72'	S0°39'28"W
L12	26.00'	N0°52'44"E

### LINE TABLE

LINE	LENGTH	BEARING
L13	28.84'	N89°14'18"W
L14	11.97'	S0°45'42"W
L15	22.68'	S86°18'18"W
L16	50.03'	S88°24'57"W
L17	49.99'	N89°52'18"W
L18	50.56'	N84°57'41"W
L19	7.50'	N89°25'17"W
L20	15.00'	N0°34'43"E
L21	7.50'	S89°25'17"E
L22	0.06'	S0°34'38"W
L23	25.00'	N89°25'22"W

THIS INSTRUMENT PREPARED BY:  
KAYE M. JAMESON, P.S.M. 5912

**CFB** CLYMER FARNER BARLEY  
CLYMER FARNER BARLEY, Inc.  
4450 NE 83RD RD. WILDWOOD, FL 34785  
(352) 748-3128  
WWW.CFB-INC.COM CA #4709





**City of Fruitland Park, Florida**  
**Community Development Department**  
 506 W. Berckman St., Fruitland Park, Florida 34731  
 Tel: (352) 360-6727 Fax: (352) 360-6652  
 www.fruitlandpark.org

<i>Sta Use Only</i>	
Case No.:	_____
Fee Paid:	_____
Receipt No.:	_____

## Development Application

Contact Information:

Owner Name: Mark Asplund - Senior Project Manager - Walmart Stores East LP  
 Address: PO Box 8050 MS 0555, Bentonville, FL 72712  
 Phone: \_\_\_\_\_ Email: mark.asplund@walmart.com

Applicant Name: Mark Asplund - Walmart Stores East LP  
 Address: PO Box 8050 MS 0555, Bentonville, FL 72712  
 Phone: \_\_\_\_\_ Email: mark.asplund@walmart.com

Engineer Name: Leopoldo Ayala, PE  
 Address: 500 West Fulton St. Sanford, FL 32771  
 Phone: 407.322.6841 Email: layala@cphcorp.com

Property and Project Information:

**PROJECT NAME\*:** Leesburg LBA #800  
\*A project name is required for all submissions. Please choose a name representative of the project for ease of reference.

Property Address: 2501 Citrus Blvd. Leesburg, FL 34748

Parcel Number(s): 10-19-24-0003-000-03401 & 15-19-24-0002-000-08000 Section: 10 & 15 Township: 19 Range 24E

Area of Property: 25.36 acres Nearest Intersection: Dr. Martin Luther King Jr. Blvd. & Citrus Blvd.

Existing Zoning: C-2 Existing Future Land Use Designation: Commercial

Proposed Zoning: No change Proposed Future Land Use Designation: No change

The property is presently used for: Walmart Retail Store

The property is proposed to be used for: Walmart Retail Store with a Liquor Box addition

Do you currently have City Utilities? No

Application Type:

- |                                              |                                                |                                                 |                                              |
|----------------------------------------------|------------------------------------------------|-------------------------------------------------|----------------------------------------------|
| <input type="checkbox"/> Annexation          | <input type="checkbox"/> Comp Plan Amendment   | <input type="checkbox"/> Rezoning               | <input type="checkbox"/> Planned Development |
| <input checked="" type="checkbox"/> Variance | <input type="checkbox"/> Special Exception Use | <input type="checkbox"/> Conditional Use Permit | <input type="checkbox"/> Final Plat          |
| <input type="checkbox"/> Minor Lot Split     | <input type="checkbox"/> Preliminary Plan      | <input type="checkbox"/> Construction Plan      | <input type="checkbox"/> ROW/Plat Vacate     |
| <input type="checkbox"/> Site Plan           | <input type="checkbox"/> Minor Site Plan       | <input type="checkbox"/> Replat of Subdivision  |                                              |

Please describe your request in detail: Variance request to allow 18' depth parking stalls at the liquor box facility to match the existing conditions of the Walmart parking lot.

**Required Data, Documents, Forms & Fees**

Attached to this application is a list of **REQUIRED** data, documents and forms for each application type as well as the adopted fee schedule. These items must be included when submitting the application package. Failure to include the supporting data will deem your application package **INCOMPLETE** and will not be processed for review.

Printed Name: Mark Asplund

Signature: [Signature] Date: 10/1/20

If application is being submitted by any person other than the legal owner(s) of the property, the applicant must have written authorization from the owner to submit application.

# Development Application Checklist

## The Following are Required for ALL Development Applications:

- Legal Description (Word file req'd)     Current Deed     Aerial Photo  
 Property Appraiser Information     Electronic Copy of Application     Location Map

Pre-application conferences are strongly encouraged. Submit TWO CDs with ALL documents in pdf; those that are generated as CAD files should be submitted in pdf and dwg formats. . Legal Descriptions should also come with a MS Word file of the legal description. Most maps are accessible through [www.lakecountyfl.gov/maps/](http://www.lakecountyfl.gov/maps/). Note: All maps are required to depict adjacent properties at a minimum.

**Failure to provide adequate maps may delay the application process.**

## Other Required Analyses and Maps:

### Small Scale Comprehensive Plan Amendment Applications:

- Justification for Amendment     Environmental Constraints Map     Requested FLU Map

### Large Scale Comprehensive Plan Amendment Applications:

Maps:     Environmental Constraints     Soils     Requested FLUM Designation     Requested Zoning Map Designation

Analyses:     Environmental Assessment     Utility Availability Analysis     Urban Sprawl Analysis     School Impact Analysis  
 Traffic Impact Analysis     Consistency with the Comp Plan     Florida Master Site File sign-off or Archaeological Survey

Rezoning Applications:     Requested Zoning Map     Justification for Rezoning

### Planned Development Applications:

Maps/Plans:     Conceptual Plan as Described in LDRs Chapter 154, Section 154.030,10,G     Environmental Constraints

Analyses:     Environmental Assessment     Traffic Impact Analysis     Preliminary Concurrency Analysis

Variance Applications:     Justification for Variance

### Special Exception Use Applications:

- Justification for Special Exception Use  
 Site Sketch     List of Special Requirements as Described in LDRs, Chapter 155

### Conditional Use Permit Applications:

- Proposed List of Conditions and Safeguards  
 Site Plan as Described in LDRs, Chapter 155     Written Statement as Described in LDRs, Chapter 155

### Subdivision Applications:

(Preliminary Plan, Improvement Plan and Final Plat)

- As Described in LDRs, Chapter 157

### Minor Subdivision Applications:

- As Described in LDRs, Chapter 157

### Site Plan Applications:

- As Described in LDRs, Chapter 160



APPLICANT AFFIDAVIT

STATE OF FLORIDA

COUNTY OF LAKE

Before me the undersigned authority, personally appeared Mark Asplund

Senior Project Manager, who being by me first duly sworn on oath deposes and says:

- 1) That he/she affirms and certifies that he/she understandings and will comply with all ordinances, regulations, and provisions of the City of Fruitland Park, Florida, and that all statements and diagrams submitted herewith are true and accurate to the best of his/her knowledge and belief, and further that this application and attachments shall become part of the Official Records of the City of Fruitland Park, Florida, and are not returnable.
- 2) That the submittal requirements for the application have been completed and attached hereto as part of that application.
- 3) That he/she desires City of Fruitland Park to allow CPH, Inc. to serve as Wal-Mart's authorized agent for the purpose of seeking a Variance from code Section 162.060 to allow a reduction of standard parking space size.

[Signature]  
Affiant (Applicant's Signature)

State of ~~Florida~~ Arkansas  
County of Benton

The Foregoing instrument was acknowledged before me this 8 day of Oct, 2020,  
by Mark Asplund who is personally known to me or has produced  
\_\_\_\_\_ as identification and who did or did not take an oath

(Notary Seal)

Notary Public - State of Florida  
Commission No 12351038  
My Commission Expires 10-10-2026

[Signature]  
Signature  
Crystal Uphoff  
Printed Name

CRYSTAL UPHOFF  
NOTARY PUBLIC  
Benton County, Arkansas  
My Commission Expires 10/10/2026  
Commission Number 12351038

OWNER'S AFFIDAVIT

STATE OF FLORIDA

COUNTY OF LAKE

Before me the undersigned authority, personally appeared Mark Asplund

Senior Project Manager, who being by me first duly sworn on oath deposes and says:

- 1) That he/she is the fee-simple owner of the property legally described on attached page of this application.
- 2) That he/she desires City of Fruitland Park to allow CPH, Inc. to serve as Wal-Mart's authorized agent for the purpose of seeking a Variance from code Section 162.060 to allow a reduction of standard parking space size.
- 3) That he/she has appointed CPH, Inc. to act as agent on his/her behalf to accomplish the above. The owner is required to complete the Applicant's Affidavit of this application if no agent is appointed to act on his/her behalf.

[Signature]  
Affiant (Owner's Signature)

State of ~~Florida~~ Arkansas

County of Benton

The Foregoing instrument was acknowledged before me this 8 day of Oct, 2020 by Mark Asplund who is personally known to me or has produced as identification and who did or did not take an oath (Notary Seal)

Notary Public - State of Florida  
Commission No 12351038  
My Commission Expires 10-10-2026

[Signature]  
Signature  
Crystal Uphoff  
Printed Name

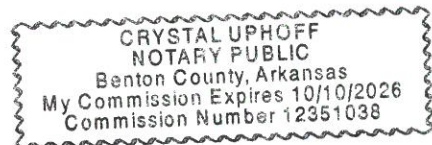

# LOCATION MAP

LAKE COUNTY, FLORIDA  
SECTIONS 10 & 15 -TOWNSHIP 19 SOUTH-RANGE 24 EAST

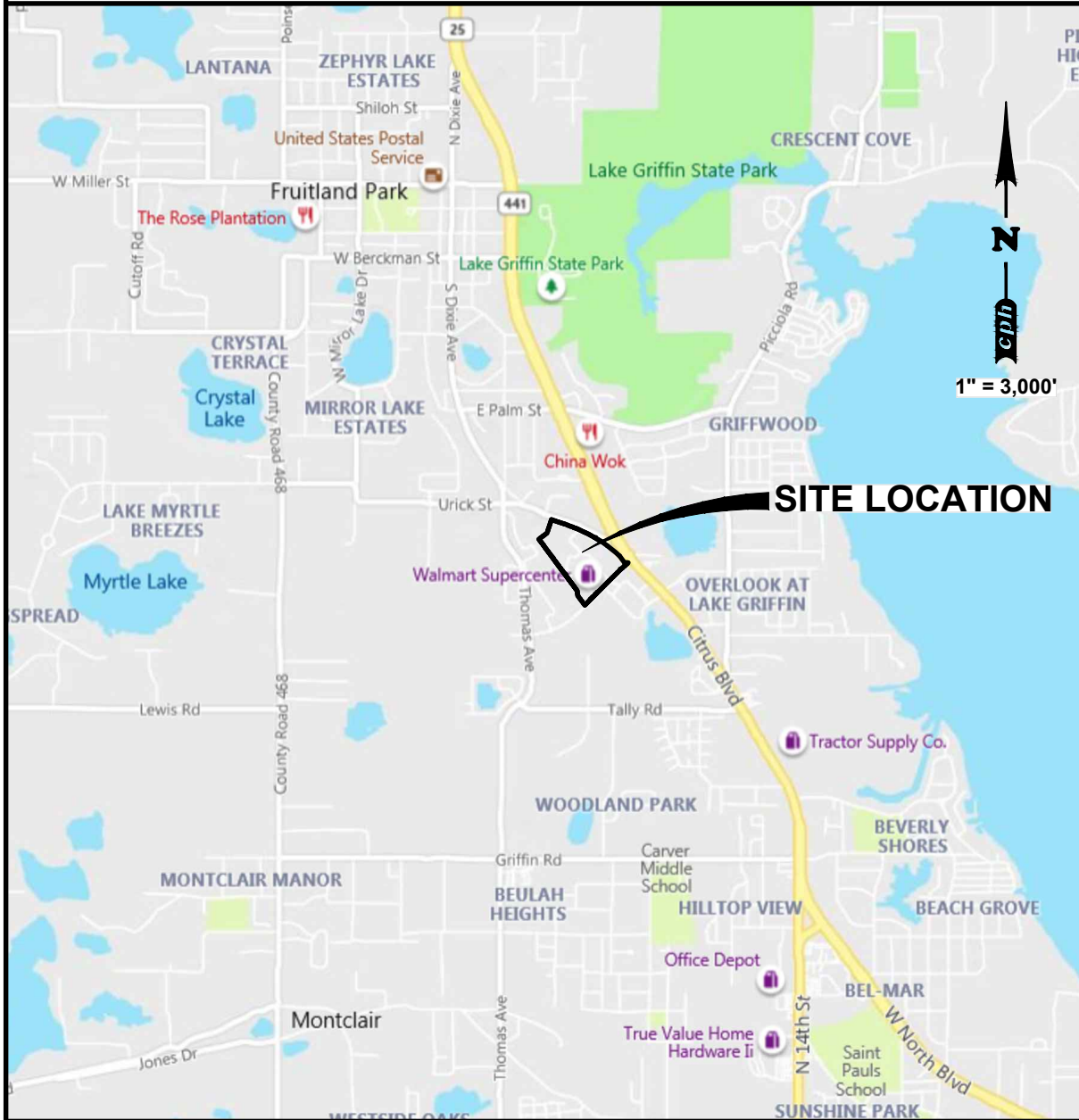





1992 SW 1st Street  
Miami, FL 33135  
Phone: 305.274.4805  
Fax: 305.274.4807

October 2, 2020

Tracy Kelley, Community Development Director  
Community Development Department City of Fruitland Park  
506 W Berckman Street  
Fruitland Park, FL 34731

**RE: Wal-Mart Liquor Addition – Variance**  
**Wal-Mart Store No. 800**  
**2501 Citrus Blvd, Leesburg, FL 34748**  
**CPH Project No. C4622**  
**Parcel ID: 10-19-24-0003-000-03401**  
**Alt Key: 1170605**

To whom it may concern,

As part of Walmart Store #800 property improvement, Walmart has elected to modify the current site configuration to add a Liquor Building Addition within the existing parking lot. Walmart Store #800 is located at 2501 Citrus Blvd, Leesburg, FL 34748. The proposed modifications are designed to improve customer service and store operations.

The proposed Liquor Building Addition and site improvements will be positioned in a manner that keeps within the confines of the existing parking lot and follows the parking row alignment, which will create minimal impacts to current traffic circulation and avoid an increase of on-site impervious area. The existing parking throughout the overall Walmart development provides a parking space size of 10' x 18', which was originally approved by City of Fruitland Park in 1998. In order to maintain consistency with the existing development, it is proposed that the Building Addition site improvements would incorporate 10' x 18' parking spaces.

On behalf of the applicant, CPH respectfully requests staff support of this Variance from code Section 162.060, to allow reduction of standard parking space size of 10' x 20' to 10' x 18'.

Sincerely,  
**CPH, Inc.**

A handwritten signature in blue ink, appearing to read 'Kevin Brown', is written over a light blue horizontal line.

Kevin Brown  
Program Manager

**RESOLUTION 2020-066**

**A RESOLUTION OF THE CITY COMMISSION OF THE CITY OF FRUITLAND PARK, FLORIDA, GRANTING A VARIANCE FROM SECTION 162.060 OF THE LAND DEVELOPMENT REGULATIONS TO ALLOW A REDUCTION IN THE PARKING SPACE SIZE FROM 10' X 20' TO 10' X 18' FOR THE ADDITION OF A WAL-MART LIQUOR STORE ON PROPERTY LOCATED AT 2501 CITRUS BOULEVARD IN THE CITY OF FRUITLAND PARK, FLORIDA, OWNED BY WAL-MART STORES EAST, LP; PROVIDING FOR AN EXPIRATION DATE; PROVIDING FOR SCRIVENER'S ERRORS; AND PROVIDING FOR AN EFFECTIVE DATE.**

**WHEREAS**, CPH, Inc. as agent on behalf of the owner, Wal-Mart Stores East, LP, has petitioned for a variance for the property located at 2501 Citrus Blvd., in the City of Fruitland Park, Florida; and

**WHEREAS**, the owner desires to request a variance from Sec. 162.060 of the Land Development Regulations that require a standard parking space of 10' x 20';

**WHEREAS**, the City Commission has considered the petition in accordance with standards for the granting of variances contained in Chapter 168, City of Fruitland Park Land Development Regulations,

**NOW THEREFORE, BE IT RESOLVED BY THE CITY COMMISSION OF THE CITY OF FRUITLAND PARK, FLORIDA**, as follows:

1. The petition for variance filed by Wal-Mart Stores East, LP for property located on 2501 Citrus Blvd., in the City of Fruitland Park, Florida, more particularly described in **Exhibit A** attached hereto and incorporated herein is **GRANTED** as follows:
2. A variance to Sec. 162.060 parking standard requirements for a parking space of 10' x 20' is reduced to 10' x 18'.
3. The variance is granted only for the Wal-Mart liquor store addition only.
4. If the variance has not been utilized within two (2) years of being granted it shall expire.
5. Scrivener's errors in the legal description may be corrected without a public hearing or at public meeting, by re-recording the original resolution or a certified copy of the resolution and attaching the correct legal description.
6. This variance shall become effective immediately on its approval and adoption by the City Commission of the City of Fruitland Park, Florida.

**PASSED AND ADOPTED** in regular session of the City Commission of the City of Fruitland Park, Lake County, Florida, this \_\_\_\_\_ day of \_\_\_\_\_, 2020.

---

Chris Cheshire, Mayor



City of Fruitland Park, Florida

ATTEST:

Approved as to Form:

\_\_\_\_\_  
Esther Coulson, CMC, City Clerk

\_\_\_\_\_  
Anita Geraci-Carver, City Attorney

Vice-Mayor Gunter	_____ (Yes), _____ (No), _____ (Abstained), _____ (Absent)
Commissioner DeGrave	_____ (Yes), _____ (No), _____ (Abstained), _____ (Absent)
Commissioner Mobilian	_____ (Yes), _____ (No), _____ (Abstained), _____ (Absent)
Commissioner Bell	_____ (Yes), _____ (No), _____ (Abstained), _____ (Absent)
Mayor Cheshire	_____ (Yes), _____ (No), _____ (Abstained), _____ (Absent)

Passed First Reading \_\_\_\_\_

**Exhibit A**  
**Legal Description**

**Parcel ID: 10-19-24-0003-000-03401**  
**Alt. Key: 1170605**

**DATE:** 10/9/2020  
**PROJECT:** Walmart Liquor Addition Variance  
**ADDRESS:** 2501 Citrus Blvd, Leesburg, FL 34748  
**ALT KEY(S):** 1770605, 1289106 & 3365216

	AltKey	OwnerName	OwnerAddress	OwnerCity	ST	ZIP	PropertyAddress
1	3564120	ABSOLUTE DEVELOPMENT CORP	4201 W CYPRESS ST	TAMPA	FL	33607	1415 DR MARTIN LUTHER KING JR BLVD LEESBURG FL 34748
2	1772419	ABSOLUTE DEVELOPMENT CORP C/O MARVIN F POER & CO	PO BOX 52427	ATLANTA	GA	30355	2479 CITRUS BLVD LEESBURG FL 34748
3	1434106	AMERICAN FEDERATED TITLE CORP TRUSTEE	3850 HOLLYWOOD BLVD STE 400	HOLLYWOOD	FL	33021	WILLIAM DR FRUITLAND PARK FL 34731
4	3784885	B MIRACLE TOUCH CORP	2476 CITRUS BLVD	LEESBURG	FL	34748	2476 CITRUS BLVD LEESBURG FL 34748
5	1288991	BAIRD MOBILE HOMES OF LEESBURG INC	3495 US HIGHWAY 441/27	FRUITLAND PARK	FL	34731	3495 US HIGHWAY 441 FRUITLAND PARK FL 34731
6	2842946	C&C II FLORIDA SUCCESS LLC	1071 PEMBERTON HILL RD STE 202	APEX	NC	27502	2480 CITRUS BLVD LEESBURG FL 34748
7	1740789	CHEVALIER MIRIAM LIFE ESTATE	1101 MARILYN ST	FRUITLAND PARK	FL	34731	1111 SOUTH DIXIE AVE FRUITLAND PARK FL 34731
	1434114	CHEVALIER MIRIAM LIFE ESTATE	1101 MARILYN ST	FRUITLAND PARK	FL	34731	SOUTH DIXIE AVE FRUITLAND PARK FL 34731
8	3818467	CHPC LEESBURG LTD C/O EASLEY MCCALED & ASSOCIATES	431 E HORATIO AVE STE 120	MAITLAND	FL	32751	2511 SENNETT DR LEESBURG FL 34748
9	1289742	CLARK RICHARD B	2473 N CITRUS BLVD	LEESBURG	FL	34748	2473 NORTH CITRUS BLVD LEESBURG FL 34748
10	3601424	CRAIG-SMITH AMANDA V	415 WILLIAM DR	FRUITLAND PARK	FL	34731	415 WILLIAM DR FRUITLAND PARK FL 34731
11	1809649	CSX TRANSPORTATION INC TAX DEPT C910	500 WATER ST	JACKSONVILLE	FL	32202	DR MARTIN LUTHER KING JR BLVD LEESBURG FL 34748
12	1740622	DTR LEASING CORP	2901 S OSCEOLA AVE	ORLANDO	FL	32806	34137 COUNTY ROAD 25A FRUITLAND PARK FL 34731
13	3606949	FIRST CHURCH OF THE NAZARENE INC	2100 DR MARTIN LUTHER KING JR BLVD	LEESBURG	FL	34788	2100 DR MARTIN LUTHER KING JR BLVD LEESBURG FL 34748
14	1740657	FIRST FLORIDA INTEGRITY BANK	3560 KRAFT RD	NAPLES	FL	34105	3460 SOUTH US HIGHWAY 27/441 FRUITLAND PARK FL 34731

15	1699754	FRUITLAND PARK HOLDINGS LLC	1330 SAXON BLVD	ORANGE CITY	FL	32763	SOUTH DIXIE AVE FRUITLAND PARK FL 34731
16	1772346	GATOR LEESBURG PARTNERS LLLP	7850 NW 146TH ST 4TH FLOOR	MIAMI LAKES	FL	33016	2219 CITRUS BLVD LEESBURG FL 34748
	3562879	GATOR LEESBURG PARTNERS LLLP	7850 NW 146TH ST 4TH FLOOR	MIAMI LAKES	FL	33016	CITRUS BLVD LEESBURG FL 34748
17	2762039	HARDMAN WALTER L III & ADAM J HARDMAN	19420 MORDEN BLUSH DR	LUTZ	FL	33558	1013 SOUTH DIXIE AVE FRUITLAND PARK FL 34731
18	1087538	JOHNSON ERNEST L JR TRUSTEE & INA L JOHNSON	1255 N 15TH ST UNIT 7	IMMOKALEE	FL	34142	SOUTH DIXIE AVE LEESBURG FL 34748
19	3891864	LAKE COUNTY BCC ATTN COUNTY ATTORNEY	315 W MAIN ST	TAVARES	FL	32778	SOUTH DIXIE AVE FRUITLAND PARK FL 34731
20	3502507	LEESBURG MEDICAL PROPERTIES LLC	4260 NE 35TH ST	OCALA	FL	34479	2500 CITRUS BLVD LEESBURG FL 34748
	1740738	LEESBURG MEDICAL PROPERTIES LLC	4260 NE 35TH ST	OCALA	FL	34479	2490 CITRUS BLVD LEESBURG FL 34748
21	3605187	MC DONALD KATHLEEN	417 WILLIAM DR	FRUITLAND PARK	FL	34731	417 WILLIAM DR FRUITLAND PARK FL 34731
22	1171237	MC HAWK LLC	2900 W ORANGE AVE STE 155	APOPKA	FL	32703	DR MARTIN LUTHER KING JR BLVD LEESBURG FL 34748
23	2542713	MCE OF FRUITLAND PARK INC	1760 LAKE TERRACE DR	EUSTIS	FL	32726	3487 HIGHWAY 27/441 N FRUITLAND PARK FL 34731
24	3800826	MURPHY OIL USA INC ATTN PROPERTY TAX	PO BOX 7300	EL DORADO	AR	71731	1801 DR MARTIN LUTHER KING JR BLVD LEESBURG FL 34748
25	2992832	PINTADO WILLIAM D & TERESA M LEE	414 WILLIAM DR	FRUITLAND PARK	FL	34731	414 WILLIAM DR FRUITLAND PARK FL 34731
26	3601441	SHOCKLEY JUDY A	416 WILLIAM DR	FRUITLAND PARK	FL	34731	416 WILLIAM DR FRUITLAND PARK FL 34731
27	3601319	SINACORE CHRISTOPHER	1322 WREN AVE	LEESBURG	FL	34748	405 WILLIAM DR FRUITLAND PARK FL 34731
28	3502477	STAR FIVE PROPERTIES INC C/O LILIA PARDO	PO BOX 140865	CORAL GABLES	FL	33114	2508 CITRUS BLVD LEESBURG FL 34748
29	2908581	TOUSSAINT NICHOLAS E TRUSTEE	PO BOX 2609	CARLSBAD	CA	92018	2271 CITRUS BLVD LEESBURG FL 34748
30	1288908	W H BARNES INC	324 BURLEIGH BLVD	TAVARES	FL	32778	3480 US HIGHWAY 441/27 FRUITLAND PARK FL 34731

31	1170605	WAL-MART STORES EAST LP WAL MART PROPERTY TAX DEPT	PO BOX 8050 MS 0555	BENTONVILLE	AR	72712	2501 CITRUS BLVD LEESBURG FL 34748
	1289106	WAL-MART STORES EAST LP WAL MART PROPERTY TAX DEPT	PO BOX 8050 MS 0555	BENTONVILLE	AR	72712	SOUTH DIXIE AVE FRUITLAND PARK FL 34731
	3365216	WAL-MART STORES EAST LP WAL MART PROPERTY TAX DEPT	PO BOX 8050 MS 0555	BENTONVILLE	AR	72712	2501 CITRUS BLVD LEESBURG FL 34748
	3760671	WAL-MART STORES EAST LP WAL MART PROPERTY TAX DEPT	PO BOX 8050 MS 0555	BENTONVILLE	AR	72712	DR MARTIN LUTHER KING JR BLVD FRUITLAND PARK FL 34731
32		BOCC COMMISSION	315 W MAIN ST	TAVARES	FL	32778	
33		SCHOOL BOARD OF LAKE COUNTY	201 W BURLEIGH BLVD	TAVARES	FL	32778	

Mailings by Certified Mail U.S. Postal Service on:

11/04/20  
Date

Certified by: Kelly Turner  
Kelly Turner  
Administrative Assistant



**CITY OF FRUITLAND PARK**  
**NOTICE TO SURROUNDING PROPERTY OWNERS**

The City of Fruitland Park has received an application for: Variance

Applicant: CPH, Inc., as agent on behalf of the owner, Wal-Mart Stores East, LP.

Address and general location of property: 2501 Citrus Blvd, Leesburg, FL 34748;  
generally located west of Citrus Blvd and north of Dr. Martin Luther King Jr. Boulevard.

Reason for action: Applicant is seeking a variance from Section 162.060 of the City of Fruitland Park Land Development Regulations to allow for a reduction in the parking space size from 10' x 20' to 10' x 18'. Wal-Mart has elected to modify the current site configuration to for the addition of a Wal-Mart Liquor Store within the existing parking lot. Proposed parking space size would be consistent with existing parking spaces, as approved in 1998.

Other information attached: Yes X No \_\_\_\_\_

\*\*\*\*\*

There will be Public Hearings:

**Planning & Zoning Board**  
**City Commission Reading**

**Thursday, November 19, 2020 @ 6:00 p.m.**  
**Thursday, December 10, 2020 @ 6:00 p.m.**

**NOTE:** If you are opposed to this Variance Application and wish to state your reasons, please fill out and return the form below to: Fruitland Park City Hall, 506 W Berckman Street, Fruitland Park, FL 34731, or call 352-360-6727 and your name will be listed for you to speak at the scheduled P&Z Board Meeting and/or City Commission Meeting.

\*\*\*\*\*

**SURROUNDING PROPERTY OWNER**

Name: \_\_\_\_\_  
(Please Print)

Address: \_\_\_\_\_

I/We the undersigned have examined the above information for the proposed \_\_\_\_\_ and understand the nature of this request.

I/We are opposed \_\_\_\_/ not opposed \_\_\_\_\_ to this action. (check one)

I/We request to speak at P&Z Meeting \_\_\_\_\_ and/or City Commission Meeting \_\_\_\_\_.  
(check one or both)

\_\_\_\_\_  
Addressee Signature

\_\_\_\_\_  
Addressee Signature

***In the event this form is not mailed back to the City or you have not called the City to schedule you as a speaker, this will be considered as an approval.***

# NOTICE OF PUBLIC HEARING RESOLUTION 2020-066

A RESOLUTION OF THE CITY COMMISSION OF THE CITY OF FRUITLAND PARK, FLORIDA, GRANTING A VARIANCE FROM SECTION 162.060 OF THE LAND DEVELOPMENT REGULATIONS TO ALLOW A REDUCTION IN THE PARKING SPACE SIZE FROM 10' X 20' TO 10' X 18' FOR THE ADDITION OF A WAL-MART LIQUOR STORE ON PROPERTY LOCATED AT 2501 CITRUS BOULEVARD IN THE CITY OF FRUITLAND PARK, FLORIDA, OWNED BY WAL-MART STORES EAST, LP; PROVIDING FOR AN EXPIRATION DATE; PROVIDING FOR SCRIVENER'S ERRORS; AND PROVIDING FOR AN EFFECTIVE DATE.

The proposed Resolution will be considered at the following public meetings:

Fruitland Park Planning and Zoning Meeting on November 19, 2020 at 6:00 p.m.

Fruitland Park City Commission Meeting on December 10, 2020 at 6:00 p.m.

The public meetings will be held in the Commission Chambers located at City Hall, 506 West Berckman Street, Fruitland Park FL 34731. The meetings are open to the public and hearings may be continued as determined by the commission from time to time to a time certain. The full proposed resolution and metes and bounds legal description of property may be inspected by the public during normal working hours at City Hall. For further information call 352-360-6727. Interested parties may appear at the meetings and will be heard with respect to the proposed resolution.

A person who decides to appeal any decision made by any board, agency or council with respect to any matter considered at such meeting or hearing, will need a record of the proceedings. For such purposes, any such person may need to ensure that a verbatim record of the proceedings is made, which includes the testimony and evidence upon which the appeal is based (Florida Statutes, 286.0105). Persons with disabilities needing assistance to participate in any of these proceedings should contact Esther Coulson, City Clerk at (352) 360-6790 at least 48 hours before the date of the scheduled hearing.





# Property Posting Aerial

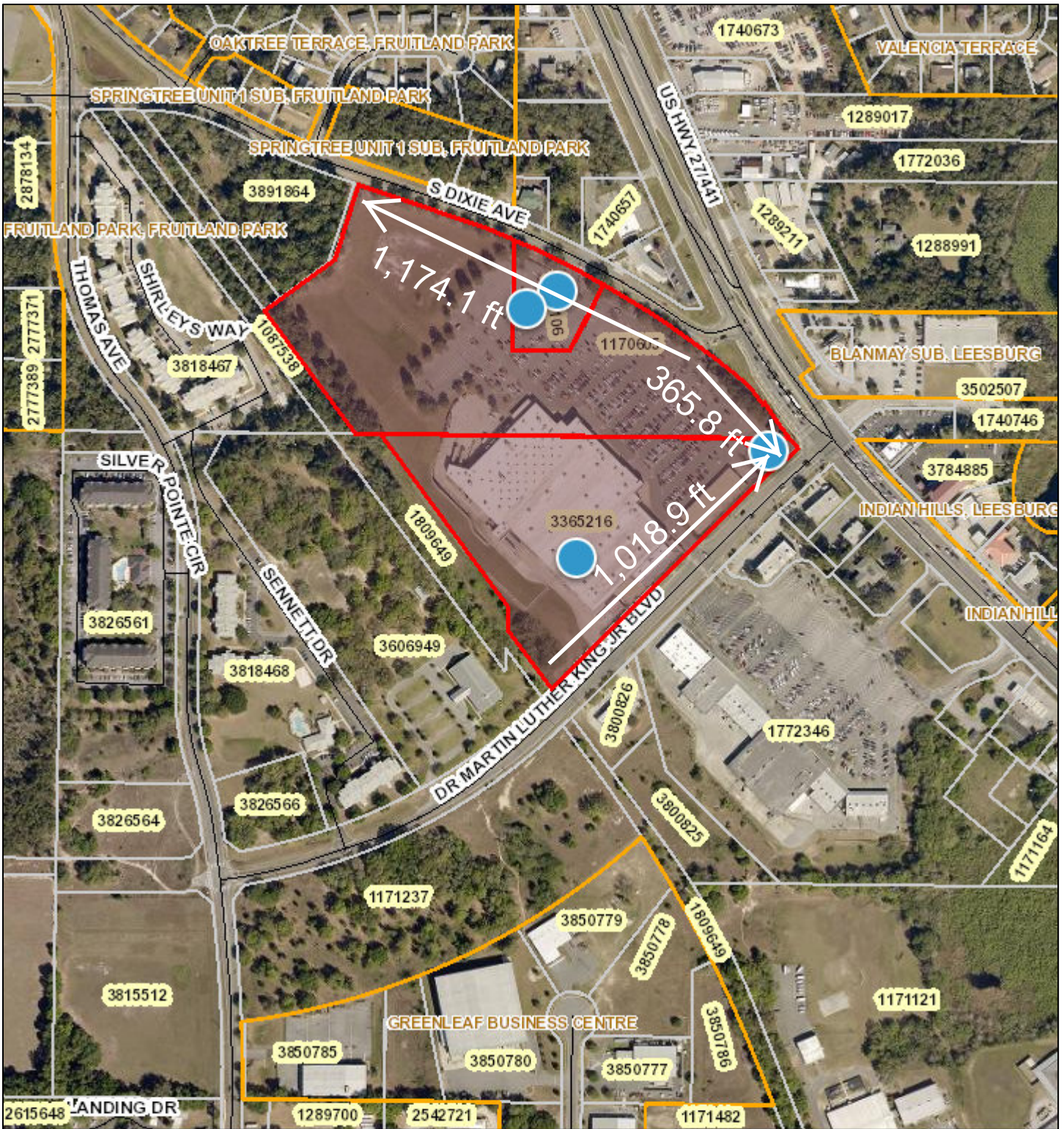

November 5, 2020

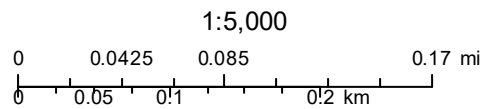

## Chapter 168.010(d)(2) Land Development Regulations

Posting of Property: Signs shall be placed, at a minimum, along all public road frontages, with a minimum of one (1) sign per five hundred (500) feet along any one (1) frontage.

\*Three (3) signs are required along South Dixie Ave road frontage. Three (3) signs are required along Dr Martin Luther King Jr Blvd road frontage. One (1) sign is required along Citrus Blvd (US HWY 27/441) road frontage. A total of seven (7) signs are required along road frontages.

\*\*Approximate distance in feet derived from measurement tool on Lake County website [gis.lakecountyfl.gov](http://gis.lakecountyfl.gov)