

**FRUITLAND PARK CITY COMMISSION
REGULAR MEETING AGENDA**

March 23, 2023 revised 032023

City Hall Commission Chambers

506 W. Berckman Street

Fruitland Park, Florida 34731

6:00 p.m.

1. CALL TO ORDER, INVOCATION AND PLEDGE OF ALLEGIANCE

Invocation – Reverend Fred Miller, Mount Pleasant AME Church

Pledge of Allegiance – Police Chief Erik Luce

2. ROLL CALL

3. SPECIAL PRESENTATIONS

(a) Water Conservation Month Proclamation – April 2023 (city clerk)

(b) February 11, 2023 5k Love Run Check Presentation (city manager/parks and recreation director)

Check presentation to “The Rock”, Leesburg High School for \$2,503.27.

(c) Ashley’s House and Cottage – Transition Home in Fruitland Park for Homeless Women Veterans Presentation (city clerk)

Ashley’s transition home for homeless women veterans’ presentation

4. CONSENT AGENDA

Routine items and items not anticipated to be controversial are placed on the Consent Agenda to expedite the meeting. If a commissioner, staff member or member of the public wish to discuss any item, the procedure is as follows: (1) Pull the item(s) from the Consent Agenda; (2) Vote on remaining item(s); and (3) Discuss each pulled item separately and vote.

(a) Approval of Minutes (city clerk)

Motion to consider the approval of the following regular meeting minutes:

March 9, 2023

- (b) **Resolution 2023-019 - Election Polling Places – Lake SOE – MOA**
(city attorney/city clerk/city manager/parks and recreation director)

A RESOLUTION OF THE CITY COMMISSION OF THE CITY OF FRUITLAND PARK, FLORIDA, APPROVING THE MEMORANDUM OF AGREEMENT FOR POLLING PLACE – 2024 – PRECINCT #530 BETWEEN LAKE COUNTY SUPERVISOR OF ELECTIONS AND THE CITY OF FRUITLAND PARK FOR THE USE OF FRUITLAND PARK'S COMMUNITY CENTER FOR THE MARCH 19, 2024 PRESIDENTIAL PREFERENCE PRIMARY ELECTION, AUGUST 20, 2024 PRIMARY ELECTION AND NOVEMBER 5, 2024 GENERAL ELECTION; AUTHORIZING THE CITY MANAGER TO EXECUTE THE AGREEMENT; PROVIDING FOR AN EFFECTIVE DATE.

5. REGULAR AGENDA

- (a) **Resolution 2023-017 Civil Engineering and Surveying Services – CR 466A Phase 3B Utility Adjustments – Halff Associates Inc.**
(city attorney/city manager/public works director)

A RESOLUTION OF THE CITY COMMISSION OF THE CITY OF FRUITLAND PARK, FLORIDA, APPROVING AGREEMENT/PROPOSAL FOR CR 466A PHASE 3B UTILITY ADJUSTMENTS DATED FEBRUARY 14, 2023 FROM HALFF IN AN AMOUNT NOT TO EXCEED \$83,600 FOR ENGINEERING, SURVEYING, PERMITTING, ADMINISTRATIVE, BIDDING AND CONSTRUCTION ADMINISTRATION SERVICES AND REIMBURSABLES; AUTHORIZING THE MAYOR TO EXECUTE THE PROPOSAL; PROVIDING FOR AN EFFECTIVE DATE. (Postponed from the February 23, 2023 meeting.)

- (b) **Resolution 2023-020 Underground 10' Utility Easement City of Leesburg Electric - New Public Works Building** (city attorney/city manager/public works director)

A RESOLUTION OF THE CITY COMMISSION OF THE CITY OF FRUITLAND PARK, FLORIDA, TO APPROVE THE PERMANENT UNDERGROUND UTILITY AGREEMENT FROM THE CITY OF FRUITLAND PARK IN FAVOR OF THE CITY OF LEESBURG, FLORIDA TO PROVIDE ELECTRIC SERVICE TO THE PUBLIC WORKS BUILDING; AUTHORIZING THE MAYOR TO SIGN THE EASEMENT; PROVIDING FOR AN EFFECTIVE DATE

- (c) **Resolution 2023-021 Public Works Building Project – Change Order #1 City of Leesburg Electric - CT Metering Equipment – GSB Construction and Development Inc.** (city attorney/city manager/public works director)

A RESOLUTION OF THE CITY COMMISSION OF THE CITY OF FRUITLAND PARK, FLORIDA, APPROVING CHANGE ORDER NO. 1 TO THE EJCDC STANDARD FORM OF AGREEMENT BETWEEN OWNER AND CONTRACTOR ON THE BASIS OF A STIPULATED PRICE BETWEEN THE CITY OF FRUITLAND PARK AND GSB CONSTRUCTION & DEVELOPMENT, INC. TO PROVIDE FOR AN INCREASE OF \$4,349.19 IN THE STIPULATED SUM; AUTHORIZING THE CITY MANAGER TO EXECUTE THE CHANGE ORDER; PROVIDING FOR AN EFFECTIVE DATE.

- (d) **Resolution 2023-022 - Public Works Building Project – Change Order #2 PVC Pipe Credit – GSB Construction and Development Inc.** (city attorney/city manager/public works director)

A RESOLUTION OF THE CITY COMMISSION OF THE CITY OF FRUITLAND PARK, FLORIDA, APPROVING CHANGE ORDER NO. 2 TO THE EJCDC STANDARD FORM OF AGREEMENT BETWEEN OWNER AND CONTRACTOR ON THE BASIS OF A STIPULATED PRICE BETWEEN THE CITY OF FRUITLAND PARK AND GSB CONSTRUCTION & DEVELOPMENT, INC. TO PROVIDE FOR A REDUCTION OF \$8,000.00 IN THE STIPULATED SUM; AUTHORIZING THE CITY MANAGER TO EXECUTE THE CHANGE ORDER; PROVIDING FOR AN EFFECTIVE DATE.

- (e) **Resolution 2023-023 - Public Works Building Project – Change Order #3 Fire Sprinkler System – GSB Construction and Development Inc.** (city attorney/city manager/public works director)

A RESOLUTION OF THE CITY COMMISSION OF THE CITY OF FRUITLAND PARK, FLORIDA, APPROVING CHANGE ORDER NO. 3 TO THE EJCDC STANDARD FORM OF AGREEMENT BETWEEN OWNER AND CONTRACTOR ON THE BASIS OF A STIPULATED PRICE BETWEEN THE CITY OF FRUITLAND PARK AND GSB CONSTRUCTION & DEVELOPMENT, INC. TO PROVIDE FOR A DECREASE OF \$18,450.00 IN THE STIPULATED SUM; AUTHORIZING THE CITY MANAGER TO EXECUTE THE CHANGE ORDER; PROVIDING FOR AN EFFECTIVE DATE.

PUBLIC HEARING

- (f) **Second Reading and Public Hearing - Ordinance 2023-001 Boundary Amendment (Annexation) - 19.10+ Acres Multi-Family Medium – South of Urick Street and West of Thomas Avenue - Petitioner: Kimaya, LLC** (city attorney/city manager/community development)

AN ORDINANCE OF THE CITY COMMISSION OF THE CITY OF FRUITLAND PARK, FLORIDA, AMENDING THE BOUNDARIES OF THE CITY OF FRUITLAND PARK FLORIDA, IN ACCORDANCE WITH THE PROCEDURE SET FORTH IN SECTION 171.044, FLORIDA STATUTES, TO INCLUDE WITHIN THE CITY LIMITS APPROXIMATELY 19.10 ± ACRES OF LAND GENERALLY LOCATED SOUTH OF URICK STREET AND WEST OF THOMAS AVENUE; DIRECTING THE CITY MANAGER TO PROVIDE CERTIFIED COPIES OF THIS ORDINANCE AFTER APPROVAL TO THE CLERK OF THE CIRCUIT COURT, THE LAKE COUNTY MANAGER AND THE DEPARTMENT OF STATE OF THE STATE OF FLORIDA; PROVIDING FOR SCRIVENER'S ERRORS, SEVERABILITY AND CONFLICTS; PROVIDING FOR AN EFFECTIVE DATE. (The first reading was held on March 9, 2023.)

- (g) **Second Reading and Public Hearing Ordinance 2023-002 SSCPA – 19.10+ Acres Multi-Family Medium – South of Urick Street and West of Thomas Avenue - Petitioner: Kimaya, LLC** (city attorney/city manager/community development)

AN ORDINANCE OF THE CITY COMMISSION OF THE CITY OF FRUITLAND PARK, FLORIDA, PROVIDING FOR A SMALL-SCALE COMPREHENSIVE PLAN AMENDMENT BY AMENDING THE FUTURE LAND USE PLAN DESIGNATION FROM LAKE COUNTY URBAN HIGH DENSITY TO CITY MULTI-FAMILY MEDIUM DENSITY OF 19.10 +/- ACRES OF PROPERTY GENERALLY LOCATED SOUTH OF URICK STREET AND WEST OF THOMAS AVENUE; DIRECTING THE CITY MANAGER OR DESIGNEE TO TRANSMIT THE AMENDMENT TO THE APPROPRIATE GOVERNMENTAL AGENCIES PURSUANT TO CHAPTER 163, FLORIDA STATUTES; AUTHORIZING THE CITY MANAGER TO AMEND SAID COMPREHENSIVE PLAN; PROVIDING FOR SEVERABILITY, CONFLICTS AND SCRIVENER'S ERRORS; REPEALING ALL ORDINANCES IN CONFLICT

HEREWITH; PROVIDING FOR AN EFFECTIVE DATE.
(The first reading was held on March 9, 2023.)

QUASI-JUDICIAL PUBLIC HEARING

- (h) Second Reading and Quasi-Judicial Public Hearing - Ordinance 2023-003 Rezoning - South of Urick Street and West of Thomas Avenue Petitioner: Kimaya, LLC (city attorney/city manager/community development)**

AN ORDINANCE OF THE CITY COMMISSION OF THE CITY OF FRUITLAND PARK, FLORIDA, REZONING 19.10 +/- ACRES OF PROPERTY FROM LAKE COUNTY AGRICULTURE (A) TO CITY OF FRUITLAND PARK R-10 WITHIN THE CITY LIMITS OF FRUITLAND PARK; GENERALLY LOCATED SOUTH OF URICK STREET AND WEST OF THOMAS AVENUE; DIRECTING THE CITY MANAGER OR DESIGNEE TO HAVE AMENDED THE ZONING MAP OF THE CITY OF FRUITLAND PARK; PROVIDING FOR SEVERABILITY, CONFLICTS AND SCRIVENER'S ERRORS; REPEALING ALL ORDINANCES IN CONFLICT HEREWITH; PROVIDING FOR AN EFFECTIVE DATE. (The first reading was held on March 9, 2023.)

END OF QUASI-JUDICIAL PUBLIC HEARING

END OF PUBLIC HEARING

- 6. (a) City Manager – Economic Development Status Update**
- (b) City Attorney**
- i. City of Fruitland Park v. State of Florida Department of Management Services**
 - ii. Michael and Laurie Fewless v. City of Fruitland Park**
 - iii. U.S. Bank National Association v. Robert Moore and City of Fruitland Park, Lake County Case No. 2022-CA-00845**
 - iv. Wayne Goodridge and Tammy Goodridge v. City of Fruitland Park, Lake County Case No. 2022-CA-1628**
 - v. Fruitland Park Official City Code**
 - vi. Kaitlin Delong vs. City of Fruitland Park, Lake County Case No. 2022-CA-00463**

7. UNFINISHED BUSINESS

8. PUBLIC COMMENTS

This section is reserved for members of the public to bring up matters of concern or opportunities for praise. Action may not be taken by the City Commission at this meeting; however, questions may be answered by staff or issues may be referred for appropriate staff action.

Note: Pursuant to F.S. 286.0114 and the City of Fruitland Park's Public Participation Policy adopted by Resolution 2013-023, members of the public shall be given a reasonable opportunity to be heard on propositions before the City Commission. Accordingly, comments, questions, and concerns regarding items listed on this agenda shall be received at the time the City Commission addresses such items during this meeting. Pursuant to Resolution 2013-023, public comments are limited to three minutes.

9. COMMISSIONERS' COMMENTS

(a) Commissioner Mobilian

(b) Commissioner Bell

(c) Commissioner Gunter

(d) Vice Mayor DeGrave

10. MAYOR'S COMMENTS

11. ADJOURNMENT

DATES TO REMEMBER

- March 25, 2023, Fruitland Park Day with BBQ Cook Off, Berckman Street, Fruitland Park, Florida 34731 at 10:00 a.m.
- April 1, 2023, Mommy and Son Mess, Northwest Lake Soccerfield, 300 Shiloh Street, Fruitland Park, Florida 34731 at 10:00 a.m.;
- April 13, 2023, City Commission regular at 6:00 p.m.;
- April 14, 2023, *State of Elections*, Lake County League of Cities, Mount Dora Golf Course, 1100 South Highland Street, Mount Dora, Florida 32757 at 12:00 p.m.;
- April 21, 2023, Comedy Night, 205 West Berckman Street, Fruitland Park, Florida 34731 at 8:00 p.m.;

- April 26, 2023, Lake~Sumter Metropolitan Planning Organization, Governing Board Meeting, 1300 Citizens Boulevard, Suite 175, Leesburg, Florida at 2:00 p.m.;
- April 27, 2023, City Commission regular at 6:00 p.m.

Please note that in addition to the city commission meetings, more than one city commissioner may be present at the above-mentioned events.

Any person requiring a special accommodation at this meeting because of disability or physical impairment should contact the City Clerk's Office at City Hall (352) 360-6727 at least forty-eight (48) hours prior to the meeting. (§286.26 F.S.)

If a person decides to appeal any decision made by the City of Fruitland Park with respect to any matter considered at such meeting or hearing, he or she will need a record of the proceedings and ensure that a verbatim record of the proceedings is made, which record includes the testimony and evidence upon which the appeal is to be based. The city does not provide verbatim records. (§286.0105, F.S.)

PLEASE TURN OFF ELECTRONIC DEVICES OR PLACE IN VIBRATE MODE

**CITY OF FRUITLAND PARK
AGENDA ITEM SUMMARY SHEET
Item Number: 3a-c**

ITEM TITLE: Special Presentations

MEETING DATE: Thursday, March 23, 2023

DATE SUBMITTED: Wednesday, March 1, 2023

SUBMITTED BY: city clerk/city manager/parks and recreation director

BRIEF NARRATIVE: Special Presentations:

- a. ***Water Conservation Month Proclamation – April 2023***(city clerk)
- b. **February 11, 2023 5k Love-Run Check Presentation** (city manager/parks and recreation director)
Check presentation to “The Rock” Leesburg High School, for \$2,503.27.
- c. **Ashley’s House and Cottage – Transition Home in Fruitland Park for Homeless Women Veterans Presentation** (city clerk)
Ashley’s transition home for homeless women veterans’ presentation

FUNDS BUDGETED: None

ATTACHMENTS: Proclamation, 5k Love-Run summary, and veterans’ brochure

RECOMMENDATION:

ACTION:



Proclamation

WHEREAS, water is a basic and essential need of every living creature; and

WHEREAS, April 2023 is the 25th anniversary being established, designated and declared by the City of Fruitland Park, The State of Florida, and the Water Management Districts as “**Water Conservation Month**”; and

WHEREAS, The Florida Section, American Water Works Association (FSAWWA) in coordination with Florida’s water management districts and the Florida Department of Environmental Protection (FDEP) recognize that as April is typically a dry month when water demands are most acute, more than ever, water conservation is becoming critical across our great state, and

WHEREAS, FSAWWA’s theme for 2023 is *Leak Prevention* which the city has continued to embody as an essential step in water conservation; St. John’s Water Management District’s message to ensure the efficient use of water: *WaterLess Florida’s Water - It’s Worth Saving*, and FDEP cites that *water conservation is the most important action we can take to sustain our water supplies, meet future needs and reduce the demands on Florida’s water-dependent ecosystems*; and

WHEREAS, the City of Fruitland Park supports water conservation and is working together encouraging every business, industry, school and citizens to make a difference when it comes to conserving water; and

WHEREAS, the city acknowledges and currently include leak prevention as its focus to help citizens and businesses to fixing leaks and to educate citizens about how they can help save Florida’s precious water resources;

NOW, THEREFORE, BE IT RESOLVED that by the virtue of authority vested in me as Mayor of the City of Fruitland Park, I, Mayor Chris Cheshire, on behalf of the city commission, do hereby proclaim the month of April 2023 as “**WATER CONSERVATION MONTH**” in the City of Fruitland Park, Florida and call upon each citizen and businesses to help protect our precious resource by practicing water-saving measures and becoming more aware of the need to save water with a special focus on fixing leaks and preventing all forms of water loss.

Chris Cheshire, Mayor
Attest:

Esther Coulson, City Clerk

Dated this 23rd day of March 2023

5K Love Run Summary 2023

Sponsorships

Platinum Sponsorship donating \$2,500

- Covenant Roofing

Gold Sponsorship donating \$1,000

- Renew Hair Salon

Silver Sponsorship donating \$500

- Disability Consultants
- Chris Semans State Farm
- Kiwanis of Lady Lake
- Tri-County Foot & Ankle
- Trinity Constructors
- Beyond the Walls Food Pantry
- Drew Davis State Farm

Bronze Sponsorship donating \$250.00

- 7 Stars
- Infinity Fitness
- Egner's Exterior Cleaning
- Danitech

Thank you to

- Citizens First Bank for sponsoring the kid's fun run once again and giving cash savings certificate prizes to 1st, 2nd, & 3rd place runners totaling \$400
- 25 Registered Volunteers. We could not have done this without you.

PROFITS \$10,794.60

Sponsorships \$8,000.00

125 Registered Runner Fees, T-Shirts, & Direct Donations

EXPENSES \$8,291.33

Walmart \$119.09, T-Shirts \$2,181.00, DRC Sports Timing Company \$1,481.25, Crown Awards \$422.34, Sign Wizard \$1,390.00

Employees x4, Police officers x2, Facility usage 2,697.65

**Check presentation for the total profit amount of 2,503.27 is being donated to
"The Rock"**



Ashley's House & Cottage Honoring 1st LT Ashley White's Ultimate Sacrifice

1st LT Ashley White was killed during combat operations in Kandahar Province, Afghanistan on Oct. 22, 2011 when the assault force she was supporting triggered an improvised explosive device. Ashley was assigned to the 230th Brigade Support Battalion, 30th Heavy Brigade Combat Team, North Carolina National Guard, Goldsboro, NC and served as a member of a Cultural Support Team attached to a Joint Special Operations Task Force Afghanistan. As a Cultural Support Team Member on her first deployment to Afghanistan, White selflessly served. Ashley's actions exemplify the highest commitment to duty, honor, and country. In every instance she served with distinction in support of the Task Force and our great nation.

Ashley was born on Sept. 3, 1987 to parents Robert and Deborah White. Ashley is survived by Robert, Deborah, her twin sister Brittany, brother Josh and husband CPT Jason Stumpf. Ashley was a graduate of Arlington H.S. (2005) and Kent State University (2009). Ashley is remembered not simply as an exemplary soldier but as the best daughter, sister, wife and friend anyone could hope to have.

Ashley was commissioned in the U.S. Army as a Medical Service Corps Officer after her graduation from Kent State University. Her awards and decorations include the Parachutists Badge, The Ohio Faithful Service Ribbon, the Armed Forces Reserve Medal, the Army Reserve Achievement Medal and the National Defense Service Medal. Ashley was posthumously awarded the Bronze Star, the Purple Heart, the Meritorious Service Medal, the Afghanistan Campaign Medal, and the Combat Action Badge.

Ashley inspired all those around her and it is the hope of her family and friends that her life will continue to inspire.

Villagers For Veterans is honored to name The New Beginnings Women Veterans Transition Homes in Central Florida after 1st LT Ashley White. Her memory will serve to inspire the many women veterans as they transition into successful civilian lives.

Campaign Purpose

To provide a safe haven for homeless women veterans where they can transition into civilian life in a safe and loving environment. A place that will facilitate training, counseling and much needed female camaraderie.

How You Can Help

- Donate Funds
- Donate Materials
- Sponsorships
- Host Fundraisers
- Volunteer
- Help Spread The Word

To Purchase a Memorial Brick or Get Further Information Visit:

www.villagersforveterans.org
or Call 516-220-5068

Why An All Female Transition Home?

Q: Why is Villagers For Veterans Taking On This Project?

A: Homeless Women Veterans is the fastest growing demographic in today's military.

According to a study performed by HUD and the VA, female veterans are more likely to be homeless than their male counterparts. They are also four times more likely to be homeless than their civilian sisters.

Although there are established transition programs provided by the military, these programs are predominately geared towards men. Female veterans find themselves isolated, with fewer options than their male counterparts and face challenges that are unique to women.

Ashley's Cottage

Transition Home
For Homeless Women Veterans
Fruitland Park, Florida



Cuddled in the beautiful city of Fruitland Park, Fl. Ashley's Cottage will serve as a transition home for 6 homeless Women Veterans while we await the completion of Ashley's House. Later, The Cottage will house overflow of homeless Women Veterans or serve as emergency housing for single Women Veterans and their children or pets.



Ashley's House

Transition Home
For Homeless Women Veterans
Eustis, Florida



Nestled In a beautiful lakefront property in Eustis, Fl. Villagers For Veterans is in the process of building a 4000 SQ ft home that will house 6 homeless Women Veterans for a minimum of 90 days in a safe and loving environment. Villagers For Veterans will facilitate career counseling, medical , financial assistance as well as school guidance.

New Beginnings Ashley's House & Ashley's Cottage



Villagers For Veterans
Changing Lives
One Veteran At A Time

501(c)3 100%
Volunteer Organization

EIN 47-1817320
Fl. Agricultural #CH-42528





Our Mission

Villagers For Veterans is 100% volunteer 501(c)3 Non-profit organization, dedicated to ensure that severely injured veterans receive assistance in healing, a return to normalcy and an independent lifestyle.

Our Monthly Meetings
4th Saturday of Every Month
Lake Miona Recreation Center
6:00 PM
We Host Many Different Events

Our Programs

Mobility & Independence
Service Dogs For Veterans
Veterans In Need
Women Veterans
PTSD Awareness



Annual Events

Orchid Gala
New Beginnings Fundraiser
Casino Night

Making A Difference One Veteran At A Time

Villagers For Veterans, Inc

www.villagersforveterans.org
516-220-5068 Cell
352-751-7611 Office



EIN: 47-1817320
FL Agriculture # CH-42528

About Us

Villagers For Veterans is 100% volunteer Organization, Founded on January 15, 2015.

Servicing Veterans wherever there is a need and making sure no Veteran falls between the cracks or left behind.

We bring awareness to the many challenges faced by our Veterans including but not limited to:

Homelessness
PTSD
Suicide
Transition

Be A Part Of The Journey

We could not do this without your help and support!

Become A Sponsor

Volunteer

Host A Fundraiser

Give an In-Kind Donation

Be A Grant Writer

Become Part of A Committee

Join Our Board

516-220-5068

Our Accomplishments

- Provided Veterans with 31 All Terrain Chairs & All Terrain Transport Vehicles
- Sponsored 15 Service Dogs
- Built a Smart ADA House for severely injured SGT Pam Kelly
- Raised 100K to sponsor all women veteran Honor Flight from Florida to Washington DC
- Helped numerous veterans with small grants to cover emergency expenses
- Currently building "Ashley's House" transition home for homeless Women Veterans
- Opened Ashley's Cottage Transition house for homeless Women Veterans



CITY OF FRUITLAND PARK
AGENDA ITEM SUMMARY SHEET
Item Number: 4a-b

ITEM TITLE: Draft Meeting Minutes and Resolution 2023-019

MEETING DATE: Thursday, March 23, 2023

DATE SUBMITTED: Wednesday, March 8, 2023

SUBMITTED BY: See below

BRIEF NARRATIVE: Routine items and items not anticipated to be controversial are placed on the Consent Agenda to expedite the meeting. If a commissioner, staff member or member of the public wish to discuss any item, the procedure is as follows: (1) Pull the item(s) from the Consent Agenda; (2) Vote on remaining item(s), and (3) Discuss each pulled item separately and vote.

(a) Approval of Minutes (city clerk)
- March 9, 2023 regular

(b) Resolution 2023-019 Election Polling Places - SOE – MOA (city attorney/city clerk/city manager/parks and recreation director)

A RESOLUTION OF THE CITY COMMISSION OF THE CITY OF FRUITLAND PARK, FLORIDA, APPROVING THE MEMORANDUM OF AGREEMENT FOR POLLING PLACE – 2024 – PRECINCT #530 BETWEEN LAKE COUNTY SUPERVISOR OF ELECTIONS AND THE CITY OF FRUITLAND PARK FOR THE USE OF FRUITLAND PARK’S COMMUNITY CENTER FOR THE MARCH 19, 2024 PRESIDENTIAL PREFERENCE PRIMARY ELECTION, AUGUST 20, 2024 PRIMARY ELECTION AND NOVEMBER 5, 2024 GENERAL ELECTION; AUTHORIZING THE CITY MANAGER TO EXECUTE THE AGREEMENT; PROVIDING FOR AN EFFECTIVE DATE.

FUNDS BUDGETED: None

ATTACHMENTS: Draft minutes and proposed resolution.

RECOMMENDATION: Approve the minutes as submitted and adopt Resolution 2023-019.

ACTION: Approve the consent agenda items.

**FRUITLAND PARK CITY COMMISSION REGULAR
DRAFT MEETING MINUTES
March 9, 2023**

A regular meeting of the Fruitland Park City Commission was held at 506 W. Beckman Street, Fruitland Park, Florida 34731 on Thursday, March 9, 2023, at 6:00 p.m.

Members Present: Mayor Chris Cheshire, Vice Mayor Patrick DeGrave, Commissioners and Chris Bell and John Mobilian.

Also present: Gary La Venia City Manager; City Attorney Anita Geraci-Carver; City Treasurer Jeannine Racine; Captain Henry Rains, Police Department; Public Works Director Robb Dicus; Deputy Finance Director Gary Bachman; Human Resources Director Betty McHale; Michael “Mike” Rankin, Interim Community Development Director, LPG Urban Regional Planners Inc. (consultant retained by the city); Deputy City Clerk Candice Dennis; Lieutenant/Paramedic Bradley Shelley and Firefighter/Emergency Medical Technician Taylor Luttfiring, Lake County Fire Rescue, and City Clerk Esther B. Coulson.

1. CALL TO ORDER, INVOCATION, AND PLEDGE OF ALLEGIANCE

Mayor Cheshire called the meeting to order, Pastor Gregory “Greg” Yarborough, Trinity Assembly Church, gave the invocation and Captain Rains led in the pledge of allegiance to the flag.

ACTION: 6:02:02 p.m. No action was taken.

2. ROLL CALL

After Mayor Cheshire requested that Ms. Coulson call the roll, a quorum was declared present.

ACTION: 6:03:14 p.m. No action was taken.

3. SPECIAL PRESENTATIONS

(a) *Irish-American Heritage Month Proclamation – March 2023*

On behalf of the city commission, Mayor Cheshire read into the record a proclamation proclaiming the month of March 2023 as *Irish-American Heritage Month* in recognition of the long history of Irish-American contributions to the State of Florida.

ACTION: 6:03:26 p.m. The proclamation was accepted with gratitude by Mr. Greg Seán Canning, Ancient Order of Hibernians, who gave an overview of St. Patrick’s Day and the origins of same being recognized and celebrated around the world and the contributions the organization has made in the United States.

(b) Sue Parker Day Proclamation

On behalf of the city commission, Mayor Cheshire read into the record a proclamation proclaiming *March 9, 2023 as Susan Parker Day* in the City of Fruitland Park and extended her the very best wishes on her retirement.

ACTION 6:10:01 p.m. The proclamation was accepted with gratitude by Ms. Parker.

4. LOCAL PLANNING AGENCY

On or before 6:15p.m. recess to the local planning agency.

ACTION 6:12:39 p.m. **By unanimous consent, the city commission recessed its meeting at 6:13 p.m. to the local planning agency.**

5. COMMUNITY REDEVELOPMENT AGENCY

On or before 6:30 p.m. recess to the community redevelopment agency.

ACTION 6:17:50 p.m. **By unanimous consent, the city commission recessed its meeting at 6:21 p.m. to the community redevelopment agency and reconvened at 6:24 p.m.**

6. CONSENT AGENDA

The city commission considered its action to approve the following consent agenda items:

(a) Approval of Minutes

Motion to consider the approval of the February 23, 2023 regular meeting minutes.

(b) Audit Engagement Letter

ACTION: 6:24:09 p.m., 6:24:38 p.m., and 6:29:15 p.m. **By unanimous consent, the city commission withdrew Consent Agenda Item 6.(b) at Vice Mayor DeGrave's request for consideration.**

On motion of Commissioner Bell, seconded by Vice Mayor DeGrave and unanimously carried, the city commission approved Consent Agenda Item 6.(a) as previously cited.

After Vice Mayor DeGrave suggested the periodical procurement of auditor services, Mr. La Venia concurred with Commissioner Bell's recommendation to implement a policy on same every three years and agreed, in response to Commissioner Gunter inquiry, to commence seeking request for proposals on same by May or June 2023 prior to the FY 2023-24 budget cycle.

After discussion and **by unanimous consent, the city commission directed staff to proceed with the request for proposals for auditor services prior to the FY 2023-24 budget process for city commission consideration on a future agenda.**

On motion of Vice Mayor DeGrave, seconded by Commissioner Bell and unanimously carried, the city commission approved Consent Agenda Item 6.(b) as previously cited.

7. REGULAR AGENDA

(a) Resolution 2023-018 Soccer Field Sidewalk Repair – FY 2022-23 Budget Amendment

Ms. Geraci-Carver read into the record proposed Resolution 2023-018, the title of which is as follows:

A RESOLUTION OF THE CITY COMMISSION OF THE CITY OF FRUITLAND PARK, FLORIDA, AMENDING THE 2022/2023 FISCAL YEAR BUDGET PURSUANT TO SEC. 6.07 OF THE CITY CHARTER TO INCREASE INSURANCE CLAIM PROCEEDS REVENUE BUDGET AND SOCCER FIELD EXPENSE BUDGET; AND PROVIDING FOR AN EFFECTIVE DATE.

ACTION: 6:29:27 p.m. After discussion, a motion was made by Vice Mayor DeGrave and seconded by Commissioner Mobilian, that the city commission adopt Resolution 2023-018 as previously cited.

Mayor Cheshire called for a roll call vote on the motion and declared it carried unanimously.

PUBLIC HEARING

(b) First Reading and Public Hearing - Ordinance 2023-001 Boundary Amendment (Annexation) - 19.10± Acres Multi-Family Medium – South of Urick Street and West of Thomas Avenue - Petitioner: Kimaya, LLC

After Ms. Geraci-Carver read into the record the following title of proposed Ordinance 2023-001; Mayor Cheshire called for interested parties to be heard:

AN ORDINANCE OF THE CITY COMMISSION OF THE CITY OF FRUITLAND PARK, FLORIDA, AMENDING THE BOUNDARIES OF THE CITY OF FRUITLAND PARK FLORIDA, IN ACCORDANCE WITH THE PROCEDURE SET FORTH IN SECTION 171.044, FLORIDA STATUTES, TO INCLUDE WITHIN THE CITY LIMITS APPROXIMATELY 19.10 ± ACRES OF LAND GENERALLY LOCATED SOUTH OF URICK STREET AND WEST OF THOMAS AVENUE; DIRECTING THE CITY MANAGER TO PROVIDE CERTIFIED COPIES OF THIS ORDINANCE AFTER APPROVAL TO THE CLERK OF THE CIRCUIT COURT, THE LAKE COUNTY MANAGER AND THE DEPARTMENT OF STATE OF THE STATE OF FLORIDA; PROVIDING FOR SCRIVENER'S ERRORS, SEVERABILITY AND CONFLICTS; PROVIDING

FOR AN EFFECTIVE DATE. (Continued from January 26 and February 9, 2023.)

After Mr. Rankin described the subject proposed Ordinance 2023-001; conveyed the January 19, 2023 Planning and Zoning Board's recommendation of approval and relayed staff's recommendation for the applicant to submit a conceptual plan with a rezoning to Multi-Family Medium Density Residential (R-10) and an adequate school determination or school concurrency reservation which was provided and confirmed that the subject project meets the minimum standards of the city's code.

After Vice Mayor DeGrave questioned the Fruitland Park Apartments revised site plan (included in the February 9, 2023 regular meeting agenda), and after Mr. Logan J. Opsahl, Lowndes et.al, Attorney representing the applicant, gave a power-point presentation on Kimaya LLC's Annexation, Small-Scale, Comprehensive Plan Amendment and Rezoning where he indicated that the site (conceptual) plan ought to have been included, Ms. Coulson confirmed in response to Mayor Cheshire's question that it together with the presentation was not provided prior to this evening's meeting. (A copy of the presentation is filed with the supplemental papers to the minutes of this meeting.)

After discussion and in response to several questions posed, Messrs. Opsahl and Mr. Charles "Chuck" C. Hiott, Half Associates, Inc. (consultants retained by the city) addressed their willingness to provide in advance visual renderings displaying the proposed residential parcels.

Mr. Hiott described the current conceptual plan with surrounding uses; the design of rented two-story town homes and three-story buildings which he claimed -- in response to Commissioner DeGrave's inquiries that was not received by the commission -- was previously provided to the community development staff, and confirmed that no garages are on the apartment site; thus, greenspaces to the south includes stormwater retention, landscape buffers, and between the buildings as well as ingress and egress.

After the city commission voiced concerns -- on the lack of recreational amenities, parking garage, the reduction of the northern section from 15 to ten units per acre (proposed development previously owned by Holloway Properties Inc.) annexation of which is between multi-family units and single-family properties; the focus on the multitude of "upscale, high-end, luxury" residential properties, and greenspaces reserved for stormwater retention and landscape buffer -- and requested an improved conceptual plan, Mr. Opsahl addressed the opportunity to meet with the elected officials to review same.

Later in the meeting, Mr. Carl Yauk, The Villages of Fruitland Park (Pine Hills resident), commended the city commission on its anticipated actions.

ACTION: 6:31:31 p.m. After discussion, Commissioner Mobilian proffered a motion to continue proposed Ordinance 2023-001 to a future meeting.

In response to Mr. Opsahl's statements and following the Ms. Geraci-Carver's advice, **a motion was made by Commissioner Mobilian and seconded by Commissioner Gunter that the city commission deny Ordinance 2023-001 as previously cited.**

By unanimous consent, Mayor Cheshire closed the public hearing.

Mayor Cheshire called for a roll call vote on the motion and declared it carried unanimously.

(c) First Reading and Public Hearing Ordinance 2023-002 SSCPA – 19.10± Acres Multi-Family Medium – South of Urick Street and West of Thomas Avenue - Petitioner: Kimaya, LLC

After Ms. Geraci-Carver read into the record the following title of proposed Ordinance 2023-002; Mayor Cheshire called for interested parties to be heard:

AN ORDINANCE OF THE CITY COMMISSION OF THE CITY OF FRUITLAND PARK, FLORIDA, PROVIDING FOR A SMALL SCALE COMPREHENSIVE PLAN AMENDMENT BY AMENDING THE FUTURE LAND USE PLAN DESIGNATION FROM LAKE COUNTY URBAN HIGH DENSITY TO CITY MULTI-FAMILY MEDIUM DENSITY OF 19.10 +/- ACRES OF PROPERTY GENERALLY LOCATED SOUTH OF URICK STREET AND WEST OF THOMAS AVENUE; DIRECTING THE CITY MANAGER OR DESIGNEE TO TRANSMIT THE AMENDMENT TO THE APPROPRIATE GOVERNMENTAL AGENCIES PURSUANT TO CHAPTER 163, FLORIDA STATUTES; AUTHORIZING THE CITY MANAGER TO AMEND SAID COMPREHENSIVE PLAN; PROVIDING FOR SEVERABILITY, CONFLICTS AND SCRIVENER'S ERRORS; REPEALING ALL ORDINANCES IN CONFLICT HEREWITH; PROVIDING FOR AN EFFECTIVE DATE. (Continued from January 26 and February 9, 2023.)

ACTION: 7:05:30 p.m. **A motion was made by Commissioner Gunter and seconded by Commissioner Mobilian that the city commission deny Ordinance 2023-002 as previously cited.**

There being no one from the public and **by unanimous consent, Mayor Cheshire closed the public hearing.**

Mayor Cheshire called for a roll call vote on the motion and declared it carried unanimously.

QUASI-JUDICIAL PUBLIC HEARING

(d) **First Reading and Quasi-Judicial Public Hearing - Ordinance 2023-003 Rezoning - South of Urick Street and West of Thomas Avenue Petitioner: Kimaya, LLC**

After Ms. Geraci-Carver read into the record the following title of proposed Ordinance 2023-003; Mayor Cheshire called for interested parties to be heard:

AN ORDINANCE OF THE CITY COMMISSION OF THE CITY OF FRUITLAND PARK, FLORIDA, REZONING 19.10 +/- ACRES OF PROPERTY FROM LAKE COUNTY AGRICULTURE (A) TO CITY OF FRUITLAND PARK R-10 WITHIN THE CITY LIMITS OF FRUITLAND PARK; GENERALLY LOCATED SOUTH OF URICK STREET AND WEST OF THOMAS AVENUE; DIRECTING THE CITY MANAGER OR DESIGNEE TO HAVE AMENDED THE ZONING MAP OF THE CITY OF FRUITLAND PARK; PROVIDING FOR SEVERABILITY, CONFLICTS AND SCRIVENER'S ERRORS; REPEALING ALL ORDINANCES IN CONFLICT HEREWITH; PROVIDING FOR AN EFFECTIVE DATE. (Continued from January 26 and February 9, 2023.)

Mayor Cheshire disclosed ex-parte communications emails dated February 8 and 9, 2023 -- accompanied with the apartment pictures, annexation aerial, January 26, 23 regular agenda, and staff report -- individually to the elected officials from Mr. Opsahl regarding project for the February 9, 2023 meeting to which the commission confirmed were not opened or read. (Copies of the email and attachments were filed with the supplemental papers to the minutes of this meeting.)

Later in the meeting, Mr. Opsahl confirmed that the emails he sent provided some of the answers addressed earlier in this evening's meeting; referred to earlier attempts made to connect with each elected official over the past three weeks, and requested an opportunity again to talk with the commission members to provide the information previously relayed to which the city commission agreed with Mayor Cheshire's response to invite developers and present same before the city commission in an open forum and not individually and concurred with Ms. Geraci-Carver's advice to provide the information including the new preliminary site (conceptual) plan requested (under Agenda Item 7.(b)) to staff to be included in the March 23, 2023 regular agenda packet.

ACTION: 7:06:50 p.m. **A motion was made by Vice Mayor DeGrave and seconded by Commissioner Bell that the city commission deny Ordinance 2023-003 as previously cited.**

There being no one from the public and **by unanimous consent, Mayor Cheshire closed the public hearing.**

Mayor Cheshire called for a roll call vote on the motion and declared it carried unanimously.

END OF QUASI-JUDICIAL PUBLIC HEARING

END OF PUBLIC HEARING

8. (a) City Manager

i. Economic Development Status Update

Mr. La Venia did not give a status on economic development.

ACTION: 7:10:33 p.m. No action was taken.

ii. Comprehensive Plan, 2020 Census (City Redistricting Map), and Multi-Family Dwelling Units Distance Requirements Status Update

At Mr. La Venia's request, Mr. Rankin gave the status of the Comprehensive Plan, 2020 Census (City Redistricting Map), and Multi-Family Dwelling Units Distance Requirements.

Earlier in the meeting, Mr. Rankin announced the following:

- The Hawthorns at Fruitland Park property (located at CR 466A and East Oliver Lane), will be closing on March 22, 2023 with the assistance from Benchmark Development I, LLC;
- Recent communication with an acquaintance on the plan to acquire Lake Saunders Grove Land LLP's property (located on Lake Ella Road, south to Spring Lake Road);
- The finalization of the cemetery map, reviewed with the city manager, which Code Enforcement Officer Lori Davis will be working on the conversion of same electronically;
- The receipt of eight pre-development applications and approximately 16 projects being addressed and three single-family residential developments being proposed, and
- 2020 Census (city redistricting map) is being worked on.

Later in the meeting, Mr. Rankin recognized that Mr. Greg Beliveau, LPG Urban Regional Planners Inc., will be the recipient of an award at the Community Service Awards to be held in May 2023.

ACTION: 7:10:33 p.m. After extensive discussion, and upon **Vice Mayor DeGrave's suggestion the city commission, by unanimous consent, directed the city attorney to provide a report at the next meeting on whether the requirements for greenspace under the land**

development code (consistent with the comprehensive plan) would apply to existing zoning permitted uses; if the applicant does not possess an application on future land use for consideration before the city commission.

(b) City Attorney

i. City of Fruitland Park v. State of Florida Department of Management Services

Ms. Geraci-Carver had nothing to report on the State of Florida Department of Management Services at this time.

ACTION: 7:36:07 p.m. No action was taken.

ii. Michael and Laurie Fewless v. City of Fruitland Park

Ms. Geraci-Carver reported that information on the Michael and Laurie Fewless case was received from the insurance company and anticipates reporting on the conclusion of same at the next meeting.

ACTION: 7:36:07 p.m. No action was taken.

iii. U.S. Bank National Association v. Robert Moore and City of Fruitland Park, Lake County Case No. 2022-CA-00845

Ms. Geraci-Carver reported that there was a hearing earlier this day on the U.S. Bank National Association v. Robert More Lake County Case No. 2022-CA-00845 at this time; addressed her intent to reach out to the attorney representing the city in that case and anticipated providing a report at the next meeting..

ACTION: 7:36:37 p.m. No action was taken.

iv. Wayne Goodridge and Tammy Goodridge v. City of Fruitland Park, Lake County Case No. 2022-CA-1628

Ms. Geraci-Carver had nothing to report on the Wayne Goodridge and Tammy Goodridge Lake County Case No. 2022-CA-1628 at this time.

ACTION: 7:36:07 p.m. No action was taken.

v. Fruitland Park Official City Code

Ms. Geraci-Carver had nothing to report on the official city code at this time.

ACTION: 7:36:07 p.m. No action was taken.

vi. Kaitlin Delong vs. City of Fruitland Park, Lake County Case No. 2022-CA-00463

Ms. Geraci-Carver had nothing to report on the Kaitlin Delong Lake County Case No. 2022-CA-00463 at this time.

ACTION: 7:36:07 p.m. No action was taken.

9. UNFINISHED BUSINESS

There was no unfinished business to come before the city commission.

ACTION: 7:36:57 p.m. No action was taken.

10. PUBLIC COMMENTS

Mr. Yauk reiterated his gratitude to the city commission for the manner in which the public hearing earlier at this evening's meeting was conducted.

Mr. Yauk referred to the city commission's adoption of the Arbor Park Phases II-III Preliminary Plat/Master Plan at its January 26, 2023 regular meeting and recognized from said plan that power would be from Duke Energy instead of City of Leesburg Electric to which Mr. La Venia corrected that the City of Leesburg will be used.

In response to Mr. Yauk's question on the approved golf cart for parks and recreation by the city commission at its January 26, 2023, Mr. La Venia confirmed that said golf cart can be used in the approved designated roadways around the city.

Answering Mr. Yauk's statements on the conduct and entire review of traffic studies prior to development, Mr. La Venia outlined the county engineers' review process and the city's technical review committee analysis on same with the developers. He anticipated the proposed roadway improvements (after the overall procurement of county bid specifications) on CR 466A to commence during summer 2023 and expected the utility adjustments for said roadway to be placed on the March 23, 2023 regular city commission agenda for consideration.

ACTION: 7:37:00 p.m. No action was taken.

11. COMMISSIONERS' COMMENTS

(a) Commissioner Mobilian

Commissioner Mobilian stated that he has nothing to report at this time.

ACTION: 7:42:03 p.m. No action was taken.

(b) Commissioner Bell

Commissioner Bell stated that he has nothing to report at this time.

ACTION: 7:42:06 p.m. No action was taken.

(c) **Commissioner Gunter – Public Safety Complex**

In response to Commissioner Gunter’s inquiry, Mr. La Venia reported on the current review and finalization of the proposed public safety complex request for qualifications, the draft of which was sent to Ms. Geraci-Carver.

ACTION: 7:42:12 p.m. After discussion, and upon Commissioner Gunter’s recommendation, **the city commission, by unanimous consent agreed to name the new public safety building in honor of former Fire Department Chief Thomas “Tommy” Lee Gamble who served the city for 54 years.**

(d) **Vice Mayor DeGrave**

Vice Mayor DeGrave reminded the city commission of his announcement at the December 8, 2022 regular meeting that he will not be attending the April 27, 2023 meeting.

ACTION: 7:43:57 p.m. No action was taken.

12. MAYOR’S COMMENTS - Dates to Remember

Mayor Cheshire recognized the following events:

- March 10, 2023, Lake County League of Cities, *Public Safety*, Mount Dora Golf Course, 1100 South Highland Street, Mount Dora, Florida 32757 at 12:00 p.m.;
- March 17, 2023, Comedy Night, Fruitland Park Community Center, 205 West Berckman Street, Fruitland Park, Florida 34731 at 8:00 p.m.;
- March 23, 2023, City Commission regular at 6:00 p.m, and
- March 25, 2023, Fruitland Park Day with BBQ Cook Off, Berckman Street, Fruitland Park, Florida 34731 at 10:00 a.m.

ACTION: 7:44:09 p.m. No action was taken.

13. ADJOURNMENT

The meeting adjourned at 7:45 p.m.

The minutes were approved at the March 23, 2023, regular meeting.

Signed

Esther B. Coulson, City Clerk, MMC

Signed

Chris Cheshire, Mayor

RESOLUTION 2023-019

A RESOLUTION OF THE CITY COMMISSION OF THE CITY OF FRUITLAND PARK, FLORIDA, APPROVING THE MEMORANDUM OF AGREEMENT FOR POLLING PLACE – 2024 – PRECINCT #530 BETWEEN LAKE COUNTY SUPERVISOR OF ELECTIONS AND THE CITY OF FRUITLAND PARK FOR THE USE OF FRUITLAND PARK’S COMMUNITY CENTER FOR THE MARCH 19, 2024 PRESIDENTIAL PREFERENCE PRIMARY ELECTION, AUGUST 20, 2024 PRIMARY ELECTION AND NOVEMBER 5, 2024 GENERAL ELECTION; AUTHORIZING THE CITY MANAGER TO EXECUTE THE AGREEMENT; PROVIDING FOR AN EFFECTIVE DATE.

WHEREAS, the City Commission is empowered pursuant to §166.021, *Florida Statutes*, to conduct municipal government, perform municipal functions, and render municipal services, and exercise any power for municipal purposes, except when expressly prohibited by law; and

WHEREAS, the City Commission is authorized by Section 163.01, Florida Statutes to enter into interlocal agreements with other governmental offices; and

WHEREAS, the City of Fruitland Park desires to provide a convenient polling location within the City of Fruitland Park for its residents to be able to cast his or her vote; and

WHEREAS, the City Commission of the City of Fruitland finds entering the Memorandum of Agreement Polling Place – 2024- Precinct #530 serves a municipal purpose and is beneficial for its residents.

NOW, THEREFORE, BE IT RESOLVED AS FOLLOWS:

Section 1. Memorandum of Agreement Polling Place – 2024- Precinct #530 between Lake County Supervisor of Elections and the City of Fruitland Park, **a copy of which is attached hereto**, is approved.

Section 2. The Commission authorizes the City Manager to execute the Agreement.

Section 3. This resolution shall take effect immediately upon its final adoption by the City Commission of the City of Fruitland Park, Florida.

PASSED AND RESOLVED this 23rd day of March 2023, by the City Commission of the City of Fruitland Park, Florida.

SEAL CITY COMMISSION OF THE CITY OF FRUITLAND PARK, FLORIDA

CHRIS CHESHIRE, MAYOR

ATTEST:

ESTHER COULSON, CITY CLERK, MMC

Mayor Cheshire	_____	(Yes),	_____	(No),	_____	(Abstained),	_____	(Absent)
Vice Mayor DeGrave	_____	(Yes),	_____	(No),	_____	(Abstained),	_____	(Absent)
Commissioner Gunter	_____	(Yes),	_____	(No),	_____	(Abstained),	_____	(Absent)
Commissioner Bell	_____	(Yes),	_____	(No),	_____	(Abstained),	_____	(Absent)
Commissioner Mobilian	_____	(Yes),	_____	(No),	_____	(Abstained),	_____	(Absent)

Approved as to form:

Anita Geraci-Carver, City Attorney

Memorandum of Agreement for Polling Place 2024 Precinct # 530

Please fill out completely. Keep a copy for your records.

The Owner/Occupant agrees to provide a Polling Place to the Lake County Supervisor of Elections for the following election(s):

Presidential Preference Primary: Tuesday, March 19, 2024
Primary Election: Tuesday, August 20, 2024
Municipal Election: Tuesday, November 5, 2024



At the following location: Fruitland Park Community Center
205 W. Berkman St., Fruitland Park
Polling Room / Building:

GENERAL INFORMATION

To the extent permitted by Section 768.28, Florida Statutes, the County of Lake, agrees to indemnify and hold harmless the Owner/Occupant for any claims for bodily injury or property damage occurring on the occupied premises arising from negligent acts of the County or any of its agents or employees. In accordance with Florida Statute 102.031(e) the owner, operator, or lessee of the property on which a polling place or an Early Voting site is located, or an agent or employee thereof, may not prohibit the solicitation of voters outside of the no-solicitation zone (measured 150' from the entrance to the polling place) during polling hours.

Rental Payment Fee is \$100.00 per Election Held.

Does the owner waive the Rental Payment Fee? Yes No

Please submit an invoice for payment to the Supervisor of Elections following each election held.

CHECK SHOULD BE MADE PAYABLE TO: City of Fruitland Park

MAILING ADDRESS: 506 W Berckman Street, Fruitland Park Fl 34731

The Polling Room MUST be opened by 6 am and is in continual use until the completion of all election activities that day. Gated communities must be open to the public at 6 am until the close of polls. Polling hours are 7:00 am – 7:00 pm.

Please Note: Voting equipment is delivered the Thursday or Friday before Election Day and pick up is the Wednesday or Thursday following Election Day. Owner/Occupant shall make reasonable efforts to safeguard equipment. Also, no video recording (including security surveillance) is allowed in polling room during polling times.

YOUR SPECIAL INSTRUCTIONS: _____

BUILDING ACCESS / USE

Is it possible for the election team to setup the polling room the afternoon before Election Day? _____
Have the Precinct Clerk sign out a key the day before the election? _____
Issue a key to an Election Office employee? _____
Supervisor of Elections shall have exclusive use of the Polling Room on Election Day? _____
Do you have tables and chairs available for the election board members to use on Election Day? _____
Is there secure on-site storage space for election equipment? _____

Yes No
Yes No
Yes No
Yes No
Yes No
Yes No

BUILDING ACCESS CONTACTS

Name: Michelle Yoder or Cindy Copen

Name: Robb Dicus

Phone Number: (352) 771-3417 or _____

Phone Number: (352) 360 6795 _____

Cell Number: (352) 638 3267 _____

Cell Number: (_____) _____ - _____

OWNER / OCCUPANT ACKNOWLEDGEMENT

City of Fruitland Park _____

Address: 201-205 W Berckman Street

Signature of Owner / Occupant _____

Fruitland Park, FL 34731

Phone Number: (352) 360-6727 _____

Date: 03 / 23 / 23

Email Address: glavenia @ fruitlandpark.org and myoder@fruitlandpark.org

Please return this form and the Polling Place Questionnaire to; duke@lakevotes.gov, or the address or fax # listed below.

1/27/2023 3:06 PM

D. ALAN HAYS, D.M.D. LAKE COUNTY SUPERVISOR OF ELECTIONS
P.O. Box 457, Tavares, FL 32778 / www.LakeVotes.gov / Tel: 352-253-1438 / Fax: 352-343-3605
duke@lakevotes.gov / bob@lakevotes.gov



POLLING PLACE QUESTIONNAIRE 2024

Please fill out completely. Keep a copy for your records.

Precinct # 530

1. Who is the facility contact person that handles election matters (equipment delivery and retrieval)? (352) 771-3417

Michelle Yoder myoder @ fruitlandpark.org (352) 771-3417
Name (Please Print) E-mail address Phone Number

2. Who is the contact person(s) who will be opening the polling place on Election Day (no later than 6:00 a.m.)?

Note: We MUST have a home phone number and a cell phone number for the opening person and emergency backup person in case the opener does not arrive by 6 a.m. If we are provided a key and/or code to enter the building, this question does not apply. If the doors to the facility are not opened by 6:00 a.m. a locksmith will be dispatched, or alternative means of entry will occur.

Michelle Yoder myoder fruitlandpark.org (352) 771-3417
Name (Opening Person) E-mail address Cell Phone #

() - Home Phone # Robb Dicus Work Phone # rdicus@fruitlandpark.org (352) 308-6651

() - Name (Emergency Back Up) E-mail address Cell Phone #

() - Home Phone # () - Work Phone #

3. Please provide the name of the electric company for this polling place: Leesburg Electric (City of)

4. Please provide the name of the water/sewer company for this polling place: City of Fruitland Park

5. Is there a kitchen facility available for election workers use (refrigerator and/or microwave)? Yes or No (Please circle one) Yes

6. Since the 2022 General Election, have any changes been made to the polling room, parking lot, sidewalks, or any areas necessary to access the polling room? Yes or No (Please circle one) No

a. If so, please explain:

7. Is there any scheduled remodeling in 2024 that may impact the polling room, parking lot, sidewalks, or any areas necessary to access the polling room? Yes or No (Please circle one) No

a. If so, please explain:

8. If the facility is monitored with an alarm system, can the opening person of the building disarm it? Yes or No (Please circle one) No alarm.

Please return this form and the Memorandum of Agreement to; duke@lakevotes.gov, or the address or fax # listed below.

D. ALAN HAYS, D.M.D. LAKE COUNTY SUPERVISOR OF ELECTIONS
P.O. Box 457, Tavares, FL 32778 / www.LakeVotes.gov / Tel: 352-253-1438 / Fax: 352-343-3605
duke@lakevotes.gov / bob@lakevotes.gov

CITY OF FRUITLAND PARK
AGENDA ITEM SUMMARY SHEET
Item Number: 5a

ITEM TITLE: Resolution 2023-017 CR 466A Phase 3B Utility Adjustments – Proposal/Agreement – Halff Associates Inc.

MEETING DATE: Thursday, March 23, 2023

DATE SUBMITTED: Friday, February 17, 2023

SUBMITTED BY: City Attorney/City Manager/Public Works Director

BRIEF NARRATIVE: Resolution 2023-017 – Proposal from Halff Associates Inc., to design, engineer and administrate water utility line expansion for the Phase 3 Roadway Expansion of County Road 466A that Lake County wants to procure in April 2023. (Postponed from February 23, 2023 meeting.)

FUNDS REQUIRED: \$83,600 (20511-60655)

ATTACHMENTS: Proposed Resolution 2023-017, change order documentation, Halff Associates Proposal/Agreement and Walter-Pierce’s proposal.

RECOMMENDATION: Staff recommends approval of Halff Associates Inc. to design the subject project.

ACTION: Adopt Resolution 2023-017

RESOLUTION 2023-017

A RESOLUTION OF THE CITY COMMISSION OF THE CITY OF FRUITLAND PARK, FLORIDA, APPROVING AGREEMENT/PROPOSAL FOR CR 466A PHASE 3B UTILITY ADJUSTMENTS DATED FEBRUARY 14, 2023 FROM HALFF IN AN AMOUNT NOT TO EXCEED \$83,600.00 FOR ENGINEERING, SURVEYING, PERMITTING, ADMINISTRATIVE, BIDDING AND CONSTRUCTION ADMINISTRATION SERVICES AND REIMBURSABLES; AUTHORIZING THE MAYOR TO EXECUTE THE PROPOSAL; PROVIDING FOR AN EFFECTIVE DATE.

WHEREAS, the City of Fruitland Park will be relocating water within the CR 466A corridor due to the widening of Phase 3 of CR 466A which will impact the watermain on the south side of CR 466A from 1000' east of Timbertop Lane to approximately 500' east of Janice Drive; and

WHEREAS, surveying, engineering, permitting, bidding and contract administration services are needed; and

WHEREAS, Halff offers the services needed by the city and a proposal in an amount not to exceed \$83,600.00 has been submitted by Halff; and

WHEREAS, the City Commission of the City of Fruitland Park, Florida finds it is in the best interest of the City to approve the proposal from Halff.

NOW, THEREFORE, BE IT RESOLVED AS FOLLOWS:

Section 1. The Agreement/Proposal for CR 466A Phase 3B Utility Adjustments dated February 14, 2023 from Halff in the amount not to exceed \$83,600.00, **a copy of which is attached**, is approved.

Section 2. The Commission authorizes the Mayor to execute the proposal.

Section 3. This resolution shall take effect immediately upon its final adoption by the City Commission of the City of Fruitland Park, Florida.

PASSED AND RESOLVED this 2023, by the City Commission of the City of Fruitland Park, Florida.

SEAL

CITY COMMISSION OF THE CITY OF
FRUITLAND PARK, FLORIDA

CHRIS CHESHIRE, MAYOR

ATTEST:

ESTHER COULSON, CITY CLERK, MMC

Mayor Cheshire	_____	(Yes),	_____	(No),	_____	(Abstained),	_____	(Absent)
Vice Mayor DeGrave	_____	(Yes),	_____	(No),	_____	(Abstained),	_____	(Absent)
Commissioner Gunter	_____	(Yes),	_____	(No),	_____	(Abstained),	_____	(Absent)
Commissioner Bell	_____	(Yes),	_____	(No),	_____	(Abstained),	_____	(Absent)
Commissioner Mobilian	_____	(Yes),	_____	(No),	_____	(Abstained),	_____	(Absent)

Approved as to form:

Anita Geraci-Carver, City Attorney



VIA EMAIL rdicus@fruitlandpark.org

February 14, 2023

Robb Dicus
City of Fruitland Park
202 W. Berckman Street
Fruitland Park, FL 34731

**RE: PROPOSAL/AGREEMENT FOR CR 466A PHASE 3B UTILITY ADJUSTMENTS,
FRUITLAND PARK, FLORIDA, LAKE COUNTY
(HALFF P43866.101)**

Dear Mr. Dicus:

SCOPE OF WORK

Prepare Utility Adjustment Plans to relocate water and sewer utilities within the CR 466A corridor due to the Lake County widening project. The Lake County CR 466A Phase 3B project will impact the watermain on the south side of CR466A from 1000' east of Timbertop Lane (First Baptist Leesburg Village Park Campus entrance) to approximately 500' east of Janice Drive in Fruitland Park, Florida. Detailed scope of services is outlined in the itemized phases below.

SCOPE OF SERVICES

PHASE 100 SURVEY SERVICES

Field locate utilities (horizontal and vertical) as marked by the City of Fruitland Park to include water services, meters and backflow preventers (see scope area below). Horizontal and Vertical control will be established via FPRN network. Deliverable will be a Civil3D autocad base file only.

FEE: \$5,600.00



PHASE 200 UTILITY ADJUSTMENT PLANS

Prepare Utility Adjustment Plans in accordance with Lake County and City of Fruitland Park requirements. Road construction plan base sheets to be obtained from Kimley-Horn and Associates, Inc. to overlay utility and survey information and prepare utility adjustment design. Plans will be on 11" x 17" sheets. Half Associates, Inc. (HALFF) will coordinate with Kimley-Horn and Associates, Inc., Lake County, and City of Fruitland Park for design adjustments to minimize cost of utility adjustments.

The following sheets are anticipated:

- Key Sheet (1 Sheet)
- 1" = 20' Utility Demo Sheets (18 Sheets)
- 1" = 20' Utility Plan Sheets (18 Sheets)
- Utility Detail Sheets (5 Sheets)

FEE: \$38,000.00

PHASE 300 PERMITTING

HALFF shall prepare the required permit applications and make submittals to the following agencies as necessary to properly permit the utility adjustments.

- Prepare and submit application and supporting documents to Florida Department of Environmental Protection for Water Distribution permit.
- Prepare and submit application for Lake County Right-of-Way Utilization Permit.

FEE: \$5,500.00

PHASE 400 PROJECT ADMINISTRATION & COMMUNICATION

The scope of services shall include administrative services necessary to coordinate all aspects of the project through the design and permitting phase. These services shall include project scheduling with all regulatory agencies and public utility companies during the design and permitting phase of the project.

The scope of services shall include HALFF attendance at project meetings, conference calls, progress meetings or other meetings requested by the client. The meetings anticipated are as follows: two (2) meetings with the City Manager/Public Works, one (1) meeting with Lake County, and one (1) meeting with Fruitland Park City Council.

**FEE: \$6,500.00 (BUDGET, NOT TO EXCEED,
TO BE BILLED HOURLY)**

PHASE 500 CONSTRUCTION BID DOCUMENTS / BIDDING SERVICES

Services to include preparation of bid documents and specifications. HALFF shall coordinate with the City and Lake County to incorporate utility adjustment work into Lake County roadway bid process. HALFF will prepare a Bid Form and an Engineer's Cost Estimate, attend pre-bid meeting with the County, answer contractor request for additional information during the bid process and evaluate bids to make recommendation.

FEE: \$4,500.00

PHASE 600 CONSTRUCTION ADMINISTRATION

HALFF will advise and consult with the City and act as the City's representative during construction. HALFF will make weekly visits to the site to observe the progress and quality of the executed site work and to determine in general if the work is proceeding in accordance with the construction drawings. HALFF will review and approve shop drawings, results of tests and inspections and other data that the contractor is required to submit.

Based upon the on-site observations and signed/sealed survey as-builts to be provided by Contractor, HALFF shall prepare and submit certifications of completions to the following State and local agencies as required:

1. City of Fruitland Park
2. Florida Department of Environmental Protection.
3. Lake County

**FEE: \$22,000.00 (BUDGET, NOT TO EXCEED,
TO BE BILLED HOURLY)**

PHASE 999 REIMBURSABLES

Costs for reimbursables, including printing, copying, blueprints, binding, mileage, etc, shall be billed at the rates shown in the attached Rate Schedule, or at cost.

FEE: \$1,500.00 (ESTIMATED, TO BE BILLED AT COST)

Our fees for the described services are outlined in the following table. We have provided “Lump Sum Fees” for the services identified in the Scope of Work. Lump Sum Fees do not include Reimbursable Expenses directly associated with the project (travel, mileage, reproduction, supplies, and other non-labor reimbursable costs.) Our fee schedule is as follows:

SCHEDULE FEE SUMMARY

PHASE 100	\$5,600.00
PHASE 200	\$38,000.00
PHASE 300	\$5,500.00
PHASE 400	\$6,500.00
PHASE 500	\$4,500.00
PHASE 600	\$22,000.00
PHASE 9999	\$1,500.00
TOTAL	\$83,600.00

THIS PROPOSAL DOES NOT INCLUDE THE FOLLOWING ITEMS:

1. As-built Survey
2. Written Specifications
3. Environmental Assessment (Threatened and Endangered Assessment)
4. Reimbursables to be billed based upon direct expense incurred by HALFF for blueprints, copies, mylars, reproductions, postage, etc.
5. Advance of permit fees, impact fees, title search fees, recording or advertising fees.
6. The above prices allow for up to two (2) response submittals for any request for additional information letters from referenced agencies. Any additional request's will be billed on an hourly basis based on the attached hourly rate schedule.

Standard Hourly Rate Schedule 2022-2023

Engineers

Principal/Officer – Professional Engineer	\$300.00
Senior Professional Engineer	\$260.00
Professional Engineer	\$185.00
Project Manager	\$155.00
Engineer Intern	\$110.00
Senior Technician	\$125.00
Design Technician	\$90.00
Project Technician	\$90.00

Survey

Survey Department Manager – P.S.M.	\$210.00
Professional Surveyor – P.S.M.	\$175.00
2 Man Field Crew	\$180.00
3 Man Field Crew	\$235.00
4 Man Field Crew	\$290.00
Senior Survey Technician	\$125.00
Survey Technician	\$100.00

GIS

Principal Officer – Senior Spatial Analyst	\$165.00
Senior Spatial Analyst	\$135.00
Spatial Analyst	\$100.00
GIS Specialist	\$60.00

Landscape Architects

Principal/Officer – Professional Landscape Architect	\$230.00
Senior Professional Landscape Architect	\$160.00
Project Manager Landscape Architect	\$150.00
Professional Landscape Architect	\$140.00
Senior Landscape Designer	\$115.00
Landscape Designer	\$85.00

Planners

Principal/Officer – Land Planner	\$265.00
Senior Planner	\$185.00
Professional Planner	\$125.00
Project Planner	\$105.00

Environmental Scientists

Senior Environmental Scientist	\$210.00
Environmental Scientist II	\$150.00
Environmental Scientist I	\$90.00

Reimbursable Expenses

Reimbursable expenses include, but are not limited to:

Courier Service	Government Permitting Fees
Maps/GIS Data	Prints, Copies, Plots, Plans
Mileage, Parking, Tolls	Subconsultant Fees
Postage and Overnight Mail	Travel (lodging, rental car, per diem)
Miscellaneous Services	

CLIENT INFORMATION FORM

To assist Halff Associates, Inc., to prepare the requested proposal, please complete the information below:

PRINT NAME & TITLE: _____

COMPANY NAME: _____

BILLING ADDRESS: _____

PHONE: _____

FAX: _____

E-MAIL: _____

BILLING CONTACT NAME & TITLE: _____

BILLING CONTACT EMAIL: _____

BILLING CONTACT PHONE: _____

CLIENT REPRESENTATIVE: _____

IS CLIENT THE OWNER OF THE SUBJECT PROPERTY? YES: _____ NO: _____

(If no, Halff Associates, Inc., reserves the right to require a retainer prior to commencing services.)

Is the property accessible? _____

If gated/locked, who shall Halff Associates, Inc. contact to gain access to the property?

NAME AND PHONE NUMBER: _____

I HEREBY CERTIFY THAT THE ABOVE INFORMATION IS TRUE TO THE BEST OF MY KNOWLEDGE.

SIGNATURE: _____

DATE: _____

March 10, 2023

Robb Dicus
Public Works Director
City of Fruitland Park
506 W. Berckman Street
Fruitland Park, FL 34731

SUBJECT: Task Order Proposal for Design Services for the Relocation of Water Mains within CR 466A Phase 3B

Dear Mr. Dicus,

Wright-Pierce would like to thank the City of Fruitland Park (City) for the opportunity to submit this proposal to provide professional engineering services for water main design on County Road (CR) 446A, Phase 3B.

Project Background/Understanding

Lake County, using the engineering services of Kimley Horn, has prepared construction documents for the reconstruction and widening of CR 466A Phase 3B. The project roadway limits are from 2,640 feet west of Josephine Drive to 348 feet east of Poinsettia Avenue for a total length of approximately 6,258 linear feet. The project involves widening the pavement from 2 lanes to 4 lanes, adding curb and gutter, a center median, a substantially altered roadway profile, and a new enclosed stormwater collection and conveyance system. The roadway and drainage improvements are located within existing or new right of way (minimum widths vary from 94-ft to 114-ft) and roadway grading will occur outside these limits in permanent easements. The County expects to begin construction in the summer of 2023.

Fruitland Park owns and maintains water mains within the roadway project limits and the proposed roadway and drainage work will require the City to relocate the water mains. Per the City, approximately 1,000 linear feet of water main is in place at both the west and east ends of the project and they are in alignment with the proposed roadway work and do not need to be relocated. The remaining 4,200 linear feet in the middle of the project contains existing mains or no mains at all. The City's objective is to have a contiguous 12-inch diameter water within the project limits. This will require the relocation of segments of existing water mains, new water mains in segments that currently lack water service, fire hydrants at a maximum of 500-ft intervals, reconnection to existing water mains at Janice Drive, Valley Road, and Cutoff Road, extension stub-outs to the north for future development, and reconnection of approximately 25 existing metered service connections.

Under our Continuing Services Agreement, the City has asked Wright-Pierce to provide a Task Order Proposal for the design of the stated water main improvements. The Scope of Work shall include the design of the water main improvements, surveying needed to support the design efforts, preparation of FDEP water main extension permit applications, coordination and communication with Lake County and their engineering consultant for design coordination, right-of-way permitting, coordination and communication with applicable

regulatory agencies and other utility owners/providers, development of an engineer's opinion of probable construction costs, preparation of bid documents and specifications for incorporation into Lake County's bid process, representation on the City's behalf during the bidding process, and construction administration. To accomplish the City's obligations and objectives, Wright-Pierce proposes the following Scope of Work, Schedule, and Compensation.

Scope of Work

Task 1 – Project Initiation, Project Management, and Administration

1.1 This task will consist of overall management of the project, invoicing, scheduling and general coordination with the City, Lake County, and other stakeholders.

1.2 Wright-Pierce will hold a kick-off meeting with the City within 7 calendar days of the Notice to Proceed (NTP). We expect this meeting to be attended by the City, Lake County, Lake County's roadway design engineer, and other utility providers/owners located within the project limits.

1.3 We will submit monthly status reports of the project progress with each invoice.

1.4 We will conduct bi-weekly project status meetings with the design team and key City staff. It is assumed the project will take 5 months to design, resulting in 10 project status meetings.

Task 1 Deliverables:

Wright-Pierce will provide the City with PDFs of the following:

- Kickoff meeting agenda and minutes (PDFs).
- Monthly status reports and/or meeting minutes (PDFs).

Task 2 – Data Collection

2.1 Wright-Pierce will require the latest electronic files of the roadway project from Lake County to serve as the existing conditions for our design efforts. These MicroStation-based design files will be converted to AutoCAD for use as base mapping for our subsequent work.

2.2 The current roadway plans do not accurately reflect the position of the City's water mains. Therefore, we will contract with Echo UES, Inc. to perform additional topographic surveying. The surveying work will include locating all visible above ground water appurtenances, verifying the existing conditions shown in the roadway plans, and updating base mapping.

2.3 Subsurface Utility Evaluations (SUE) will be performed by Echo UES, Inc. to better determine the locations of the existing water mains. SUE will be performed in two parts. Part 1 will consist of Utility Quality Level C and D. Level D is based on record drawing requests and reviews and Level C is based on the field surveys and other field observations. Wright Pierce will contact the City, Sunshine 811, and other known utility owners and request copies of their utility plans. These records will be represented in our updated base mapping.

Part 2 will consist of Utility Quality Level A which is based on the horizontal and vertical locating of utilities at a specific point using minimally invasive vacuum test holes (soft-digs). Part 1 work will be performed during the initial data collection phase of work. Part 2 will be deferred until after the 50% design efforts have been completed so the soft-digs can be targeted to areas of most concern. We expect soft-digs to be performed at the proposed water main tie-in points at the east and west ends of the project and at the connection points at Janice Drive, Valley Road, and Cutoff Road. For budgeting purposes, 10 test holes are included in this Scope of Work. Note that Quality Level A SUE is not proposed for other utilities within the project since it is expected that they will be relocated as part of the CR 466A widening.

2.4 Wright-Pierce will require copies of the geotechnical investigation report obtained/used by Lake County for the roadway project for use in our designs and contract document preparation.

Task 2 Deliverables:

No separate deliverables are associated with this task. The results of the surveying and SUE will be incorporated into the design plans.

Task 3 – Design

3.1 After obtaining and reviewing the project data and assembling AutoCAD base mapping Wright-Pierce will proceed with design efforts and plan development. This will include detailing the horizontal and vertical alignment of water mains to be relocated, delineating the extent of water utilities to be removed, and preparing construction details. Since Lake County plans to start construction in the summer of 2023, an expedited design schedule will be required. Therefore, we propose 50%, 90%, and Final design phases, and virtual design review meetings will be held with the City for each of these design phases. We anticipate the following construction drawings will be prepared for each phase:

Drawing Name	No. of Sheets	Included in 50% Design Phase	Included in 90% Design Phase	Final Design Phase
Title Sheet	1	X	X	X
General Notes	2		X	X
Abbreviations and Legends	1	X	X	X
Overall Site Plan and Key Map	1	X	X	X
Roadway Typical Sections With Water Main Locations	1	X	X	X
CR 466A Roadway & Water Main Plan & Profiles	6	X	X	X
Janice Drive, Valley Road, and Cutoff Road Water Main Profiles	3	X	X	X
Cross Sections	17	X	X	X
Sediment and Erosion Control Plans	8		X	X
Construction Details	2		X	X

3.2 Wright-Pierce will coordinate our design efforts with other private utility owners preparing their own relocation plans. We expect to participate in up to 2 virtual coordination meetings during the design process.

3.3 We will develop an Opinion of Probable Construction Costs for the proposed design.

3.4 We will prepare Contract Documents and Technical Specifications in 16 Division, CSI format. We expect these documents to include typical Division 1 contract documents, and applicable Division 2 site-related technical specifications. Florida Department of Transportation specifications will be referenced where appropriate. We expect Lake County to provide their Division 0 contract documents and we will incorporate them into our overall contract documents.

Task 3 Deliverables:

Wright-Pierce will provide the City with PDFs of the following:

- 50% Construction Drawings.
- 50% Virtual design review meeting and disposition of comments.
- 90% Construction Drawings, Contract Documents/Specifications, and Opinion of Probable Construction Cost.
- 90% Virtual design review meeting and disposition of comments.

- Final Construction Drawings, Contract Documents/Specifications, and Opinion of Probable Construction Cost (one PDF of each, digitally signed and sealed).

Task 4 – Permit Applications

4.1 Upon City approval of the 90% Construction Drawings, Wright-Pierce will complete and submit the following permit applications:

- FDEP 62-555.900 Notice of Intent to Use the General Permit for Construction of Water Main Extension for PWSs
- FDEP 62-330.453 General Permit for Installation, Maintenance, Repair, and Removal of Utility Lines
- Lake County Right-of-Way Utilization Permit.

Wright-Pierce will respond to a maximum of two requests for additional information (RAI) for each permit referenced in this scope.

Task 4 Deliverables:

Wright-Pierce will provide the City with PDFs of the following:

- FDEP permit applications (applications will be electronically uploaded to FDEP's website).
- Completed Right-of-Way Utilization Permit application.

Task 5 – Bid Phase Services

5.1 Wright-Pierce's activities during the Bid Phase Services will include:

- Attending the pre-bid meeting.
- Responding to technical questions from prospective bidders and assisting the City and County with preparing and issuing of project addenda.
- Evaluating the apparent low bidder's bid package, tabulating bids, and making a recommendation to award.
- Preparing and submitting Conformed Documents once the construction contract has been executed.

Task 5 Deliverables:

Wright-Pierce will provide the City with PDFs of the following:

- Bid documents digitally signed and sealed.
- Pre-bid meeting agenda and meeting minutes.

- Addendums (with copies to Lake County).
- Bid tabulation.
- Written Recommendation to Award to the City.
- Conformed Plans and Contract Documents digitally signed and sealed.

Task 6 – Construction Administration

Wright-Pierce will provide the following services during construction:

- Review shop drawing submitted by the Contractor for general compliance with the construction documents.
- Conduct bi-weekly on-site construction status meetings (14 meetings total).
- Perform up to 3 additional on-site observation visits to verify reasonable conformity with the construction documents. It is assumed the City will provide full-time, on-site construction observation. Wright-Pierce will coordinate with City staff during bi-weekly visits.
- Review limits of constructed work for the purpose of assessing the general accuracy of Contractor payment requests during bi-weekly on-site meetings. It is assumed the City's on-site representative will be confirming daily quantities with the Contractor.
- Review Contractor-prepared monthly pay requisitions.
- Review construction materials and other testing results provided by the City's and/or Contractor's 3rd party testing company.
- Review and respond to requests for information (RFI's) from the Contractor.
- Coordinate and prepare work change directives and change orders (two assumed).
- Review City and Contractor prepared documentation for final Record Drawings.
- Generate Substantial Completion walkthrough and punch list.
- Prepare Record Drawings based on information provided by the Contractor and the City's on-site representative. As-Builts will consist of redlines of the original construction documents.
- Perform Final Completion walkthrough and prepare letter documenting project acceptance.

Task 6 Deliverables:

Wright-Pierce will provide the City with PDFs of the following:

- Substantial Completion punch list.
- Final Completion walkthrough and letter documenting project acceptance.
- Project-related correspondences.
- Bi-weekly construction meeting notes.
- RFIs and their disposition (work directives/change orders).
- Comments on test results.
- Reviewed Contractor Pay Requests.
- Record Drawings.
- Punch lists.
- Project acceptance letter.

Schedule

We understand that Lake County expects to start construction in the Summer of 2023 and that time is of the essence. Therefore, Wright-Pierce offers the schedule below contingent upon the following expectations:

- A Purchase Order/Notice to Proceed is issued no later than March 20, 2023.
- The City has provided Wright-Pierce with copies of the roadway cad files (dated December 20, 2022). If more recent plans are available, they shall be provided to us no later than March 20, 2023.
- City design review comments and design review meetings with the City shall occur within 7 days of each submittal.
- Utility coordination meetings with Lake County and other utility providers shall occur within 7 days of our request.

Proposed Schedule

<u>Task</u>	<u>Completion</u>
Task 1 – Project Initiation, PM, and Admin.	Throughout the project
Task 2 – Data Collection	April 28, 2023
Task 3 – Design (50% Design Phase)	May 26, 2023
Task 3 – Design (90% Design Phase)	June 30, 2023
Task 3 – Design (Final Design Phase)	July 21, 2023
Task 5 – Bid Phase Services	July 28, 2023
Task 6 – Construction Administration	August 2023 to February 2024

Compensation

Wright-Pierce will complete the above Scope of Work for a lump sum fee of **\$174,800**. A further breakdown of our fee is as follows:

Task 1 – Project Initiation, Project Management, and Administration	\$17,000
Task 2 – Data Collection	\$43,000
Task 3 – Design	\$66,000
Task 4 – Permitting	\$5,100
Task 5 – Bid Phase Services	\$6,700
Task 6 – Construction Administration	\$37,000

3/10/2023

Robb Dicus

Page 8 of 8

Fees will be invoiced monthly in accordance with our General Services Contract based on our estimate of completion for each task, and each invoice will include a progress report describing the efforts performed for that period.

Clarifications and Exclusions

1. Environmental services such as ecological field assessments for threatened and endangered species and wetlands are assumed to have been addressed in the roadway project and such services are not included in this Scope of Work.
2. No additional geotechnical investigations are included in this Scope of Work.
3. The City has specified that the new water mains will be 12-inch diameter. Therefore, no hydraulic modeling is included in this Scope of Work.
4. Our proposed water mains will be designed within the rights-of-way and/or easements depicted in the roadway plans and services related to acquisition of new rights-of-way and/or easements are excluded from this Scope of Work.
5. The City shall pay for all permits and associated review fees related to the project.
6. The City or Lake County will issue bid documents to bidders, track bidders, and issue addendums.
7. Material testing will be provided by the City or Contractor.

If this proposal is acceptable, please provide an NTP and PO and we will schedule the initial kick-off meeting. We appreciate the opportunity to present this proposal and look forward to working with you and your staff. If you have any questions or require additional information, please do not hesitate to contact me at 407.794.1734 or at the e-mail address listed below.

Sincerely,

WRIGHT-PIERCE



Walter A. Nickel, PE

Senior Project Manager

walter.nickel@wright-pierce.com



Ryan T. Wingard, PE

Vice President

ryan.wingard@wright-pierce.com

CITY OF FRUITLAND PARK
AGENDA ITEM SUMMARY SHEET
Item Number: 5b

ITEM TITLE: Resolution 2023-020 Underground 10' Utility Easement
City of Leesburg Electric - New Public Works Building

MEETING DATE: Thursday, March 23, 2023

DATE SUBMITTED: Friday, March 13, 2023

SUBMITTED BY: City Attorney/City Manager/Public Works Director

BRIEF NARRATIVE: Resolution 2023-020 – Utility Easement by the City of Leesburg Electric to obtain underground electric services for the City of Fruitland Park's new public works building located at 2601 Spring Lake Road, Fruitland Park, Florida.

FUNDS REQUIRED:

ATTACHMENTS: Proposed Resolution 2023-020 and draft utility easement

RECOMMENDATION: Staff recommends approval subject to the City of Leesburg approving the form of the easement and the city attorney's review of receiving the easement exhibits from the surveyor.

ACTION: Adopt Resolution 2023-020

RESOLUTION 2023-020

A RESOLUTION OF THE CITY COMMISSION OF THE CITY OF FRUITLAND PARK, FLORIDA, TO APPROVE THE PERMANENT UNDERGROUND UTILITY AGREEMENT FROM THE CITY OF FRUITLAND PARK IN FAVOR OF THE CITY OF LEESBURG, FLORIDA TO PROVIDE ELECTRIC SERVICE TO THE PUBLIC WORK’S BUILDING; AUTHORIZING THE MAYOR TO SIGN THE EASEMENT; PROVIDING FOR AN EFFECTIVE DATE

WHEREAS, the City of Fruitland Park is constructing a new public works building and desires electric service from the City of Leesburg, and the City of Leesburg desires to provide electric service, but requires a perpetual, non-exclusive easement under, over and across a portion of the property owned by the City of Fruitland Park; and

WHEREAS, the City of Fruitland Park desires to grant the permanent underground utility easement.

NOW THEREFORE, BE IT RESOLVED BY THE CITY COMMISSION OF THE CITY OF FRUITLAND PARK, FLORIDA, AS FOLLOWS:

Section 1. The City Commission approves the Permanent Underground Utility Easement in favor of the City of Leesburg, Florida, to allow for the new public works building to be served electric service. A copy of the easement is attached hereto.

Section 2. The mayor is authorized to sign the Permanent Underground Utility Easement in favor of the City of Leesburg, Florida.

Section 3. This resolution shall take effect immediately upon its adoption by the City Commission of the City of Fruitland Park, Florida.

PASSED AND RESOLVED this 23rd day of March 2023, by the City Commission of the City of Fruitland Park, Florida.

Chris Cheshire, Mayor

Attest:

Esther B. Coulson, City Clerk, MMC

Mayor Cheshire _____ (Yes), _____ (No), _____ (Abstained), _____ (Absent)
Vice Mayor DeGrave _____ (Yes), _____ (No), _____ (Abstained), _____ (Absent)

Commissioner Gunter _____ (Yes), _____ (No), _____ (Abstained), _____ (Absent)
Commissioner Bell _____ (Yes), _____ (No), _____ (Abstained), _____ (Absent)
Commissioner Mobilian _____ (Yes), _____ (No), _____ (Abstained), _____ (Absent)

Approved as to form and legality:

Anita Geraci-Carver, City Attorney

Record and Return to:
Anita Geraci-Carver, Esq.
Law Office of Anita Geraci-Carver, P.A.
1560 Bloxam Avenue
Clermont, FL 34711

PERMANENT UNDERGROUND UTILITY EASEMENT

THIS GRANT OF A PERMANENT UNDERGROUND UTILITY EASEMENT, made this ____ day of _____, 2023, by **CITY OF FRUITLAND PARK**, a Florida municipal corporation, created under the laws of the State of Florida, 506 W. Berkman St., Fruitland Park, FL 34731 hereinafter called the Grantor, to and in favor of the **CITY OF LEESBURG**, a Florida municipal corporation, created under the laws of the State of Florida, **501 West Meadow St. Leesburg, Florida 34748**, hereinafter called the Grantee.

1. **Background.** Grantor is the owner of certain real property situate in Lake County, Florida, more particularly described in **Exhibit “A”** attached hereto and made a part hereof by this reference (the “Property”).

Grantor is constructing a new public works building on the Property and desires electric service from Grantee. Grantee desires to provide electric service to the Grantor and requires a perpetual, non-exclusive easement under, over and across a portion of the Property which is more particularly described and depicted in **Exhibit “B” attached hereto and made a part hereof by this reference (the “Utility Easement Property”)** 10+/- feet wide consisting of **5,247.14** SF for utility purposes with full authority to enter upon construct, operate, repair, replace and maintain underground electrical lines and a transformer, and all other related and appurtenant facilities over, under, through and across the Utility Easement Property. Grantor is willing to grant Grantee an easement for said purpose, subject to the terms and conditions set forth below.

2. **Grant of Easement.** In consideration of the covenants and obligations set forth herein and other good and valuable consideration in the sum of Ten and No/100 Dollars (\$10.00) paid by Grantee to Grantor, the receipt of which is hereby acknowledged, Grantor hereby grants, conveys and declares unto Grantee, its successors and assigns, a perpetual, non-exclusive utility easement including rights under, over, through and across the Utility Easement Property, for the purpose of the construction, operation, repair and maintenance of underground electrical lines, a transformer and all other related and appurtenance facilities (the “Facilities”).

3. **Use by Grantor.** Grantor retains the right to use the Utility Easement Property, so long as such rights do not unreasonably interfere with Grantee’s rights hereunder. The Property is subject to all matters of record, the retained rights of Grantor and whatever other easements, rights, licenses, or grants that contemporaneous herewith or subsequent hereto, may be granted, or otherwise created by Grantors, provided that any subsequently

created interest does not prevent Grantee from utilizing this Easement for its intended purpose. The Utility Easement Property shall revert to Grantor upon release.

4. **Grantor's Improvements.** Grantee shall replace and restore any and all improvements of Grantor within the Utility Easement Property and Grantor's adjoining land, including the Temporary Construction Easement as hereafter defined, which are disturbed by Grantee's activities (collectively, Grantor's Improvements).

5. **Maintenance.** After Grantee commences construction of the Facilities in the Utility Easement Property, Grantee shall maintain, repair and replace the Facilities in good order, condition and state of repair.

6. **Grant of Temporary Easement.** Grantor hereby grants, conveys and declares unto Grantee, its successors and assigns, a 30' wide temporary construction easement adjacent to and running along the boundary of the Utility Easement Property for the purpose of allowing the Grantee to enter upon the Temporary Easement Property with people and equipment to install the Facilities in the Utility Easement Property. The Temporary Construction Easement shall expire upon completion of construction of the Facilities within the Utility Easement Property.

7. **Covenants with the Land.** All rights, privileges, benefits and burdens created herein are covenants running with the land, binding upon and inuring to the benefit of Grantor, Grantee and their respective assigns and successors in title.

8. **Title.** Grantor does hereby covenant that Grantor is lawfully seized and possessed of the Utility Easement Property subject to no mortgages or encumbrances, and that it has good and lawful right to convey said easement without the joinder and consent of any third party.

9. **Incidental Rights.** Each of the rights and benefits granted herein shall include all those additional rights and benefits which are necessary for the full enjoyment thereof and are customarily included incidental thereto.

10. **Captions.** The captions included herein are for reference only and should not be used in construing any of the terms hereof. This Utility Easement shall be construed and enforced in accordance with the laws of the State of Florida.

11. **Attorneys Fees.** In the event that Grantor or Grantee or either of their successors in title institutes legal proceedings against the other party to enforce any term of this Utility Easement, the prevailing party shall be entitled to recover from the non-prevailing party reasonable attorneys' fees and court costs incurred incidental thereto, including, without limitation, fees and costs incurred in appellate proceeding and in bankruptcy.

IN WITNESS WHEREOF, the said first has signed and sealed these presents the day and year first above written.

Signed, sealed and delivered in the presence of:

Grantor: CITY OF FRUITLAND PARK

Witness Signature

Print Name

By: _____
Chris Cheshire, Mayor

Witness Signature

Print Name

Attest: _____
Esther Coulson, City Clerk

STATE OF FLORIDA
COUNTY OF LAKE

The foregoing instrument was acknowledged before me by means of physical presence or online notarization, this ____ day of _____, 2023 by Chris Cheshire, Mayor of the City of Fruitland Park, a Florida municipal corporation on behalf of the corporation. He is personally known to me or has produced _____ as identification.

NOTARY PUBLIC

ACCEPTED BY CITY OF LEESBURG (Grantee).

Witness Signature

Print Name

By: _____
_____, Mayor

Witness Signature

Attest: _____
City Clerk

Print Name

STATE OF FLORIDA
COUNTY OF LAKE

The foregoing instrument was acknowledged before me by means of physical presence or online notarization, this ____ day of _____, 2023 by _____, Mayor of the City of Leesburg, a Florida municipal corporation on behalf of the corporation. He is personally known to me or has produced _____ as identification.

NOTARY PUBLIC

EXHIBIT "A"
(the Property)

Parcel No. 33-18-24-0004-000-04701
Alternate Key No. 1284201

Legal Description: That part of the Northwest $\frac{1}{4}$ of the Southeast $\frac{1}{4}$ of Section 33, Township 18 South, Range 24 East, Lake County, Florida, lying West of the Westerly right of way line of the abandoned Seaboard Coast Line Railroad, LESS the North 511 feet thereof, and also LESS the South 283 feet of the West 125 feet, thereof, also LESS the South 33 feet thereof for road right of way.

That part of the abandoned Seaboard Coast Line Railroad right of way, 50 feet wide, lying in the Northwest $\frac{1}{4}$ of the Southeast $\frac{1}{4}$ of Section 33, Township 18 South, Range 24 East, Lake County, Florida, LESS the South 33 feet thereof for road right of way.

EXHIBIT “B”
(the Utility Easement Property)

See Attached

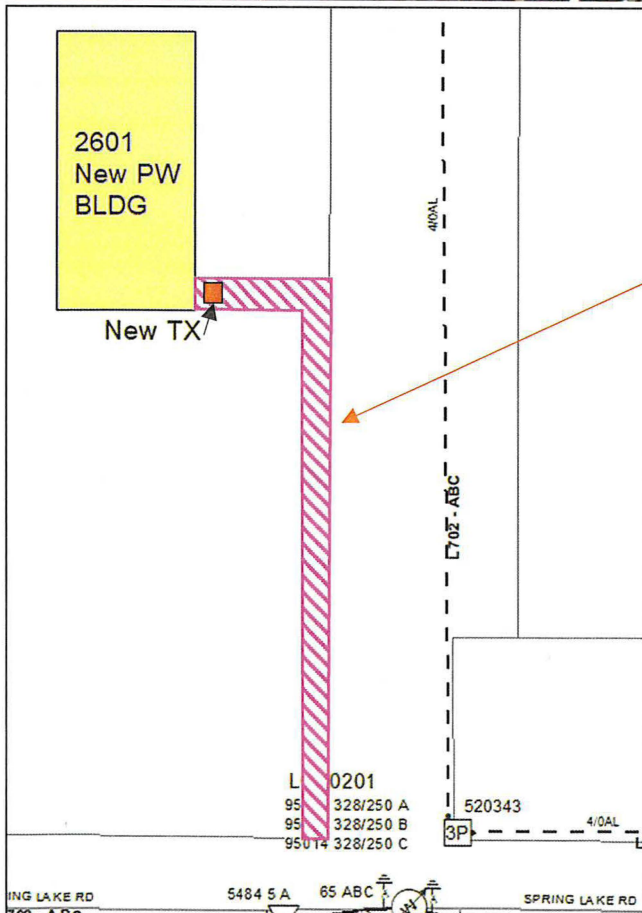

10' Utility Easement Required for New transformer and underground primary wire.

CITY OF FRUITLAND PARK
AGENDA ITEM SUMMARY SHEET
Item Number: 5c

ITEM TITLE: Resolution 2023-021 Change Order #1 CT Metering City of Leesburg Electric – GSB Construction and Development Inc.

MEETING DATE: Thursday, March 23, 2023

DATE SUBMITTED: Friday, March 17, 2023

SUBMITTED BY: City Attorney/City Manager/Public Works Director

BRIEF NARRATIVE: Resolution 2023-021 – This is a contract increase based on a specific requirement that Leesburg Electric has requested to be designed into the metering of this building. This requirement made by Leesburg Electric requires additional hardware and work to be performed by GSB Construction’s electrical sub-contractor to reduce amperage load that is sent from the power transformer to Leesburg’s electrical meter.

FUNDS REQUIRED: \$4,349.19 (Capital – 30541-60620)

ATTACHMENTS: Proposed Resolution 2023-021, change order request #1, GSB Construction, and Leesburg Electric’s request to install CT metering equipment

RECOMMENDATION: Staff recommends approval

ACTION: Adopt Resolution 2023-021

RESOLUTION 2023-021

A RESOLUTION OF THE CITY COMMISSION OF THE CITY OF FRUITLAND PARK, FLORIDA, APPROVING CHANGE ORDER NO. 1 TO THE EJCDC STANDARD FORM OF AGREEMENT BETWEEN OWNER AND CONTRACTOR ON THE BASIS OF A STIPULATED PRICE BETWEEN THE CITY OF FRUITLAND PARK AND GSB CONSTRUCTION & DEVELOPMENT, INC. TO PROVIDE FOR AN INCREASE OF \$4,349.19 IN THE STIPULATED SUM; AUTHORIZING THE CITY MANAGER TO EXECUTE THE CHANGE ORDER; PROVIDING FOR AN EFFECTIVE DATE.

WHEREAS, the City of Fruitland Park issued Invitation to Bid No. 2022-01 for construction of the City's public works building and entered into that certain contract titled EJCDC Standard Form of Agreement between Owner and Contractor on the Basis of a Stipulated Price between the City of Fruitland Park and GSB Construction & Development Inc. (the "Contract"); and

WHEREAS, the City of Leesburg requires a CT cabinet be installed thereby resulting in an increased cost to the City of \$4,349.19; therefore it is necessary to increase the Stipulated Sum by \$4,349.19; and

WHEREAS, the City Commission of the City of Fruitland Park, Florida finds it is in the best interest of the city to approve Change Order No. 1.

NOW, THEREFORE, BE IT RESOLVED AS FOLLOWS:

Section 1. The Stipulated Sum set forth in the Contract is decreased by \$4,349.19.

Section 2. The Commission authorizes the city manager to execute any required approval of such extension including Change Order No. 1, a copy of which is attached hereto.

Section 3. This resolution shall take effect immediately upon its final adoption by the City Commission of the City of Fruitland Park, Florida.

PASSED AND RESOLVED this 23rd day of March, 2023, by the City Commission of the City of Fruitland Park, Florida.

SEAL

CITY COMMISSION OF THE CITY OF FRUITLAND PARK, FLORIDA

CHRIS CHESHIRE, MAYOR

ATTEST:

ESTHER COULSON, CITY CLERK, MMC

Mayor Cheshire	_____	(Yes),	_____	(No),	_____	(Abstained),	_____	(Absent)
Vice Mayor DeGrave	_____	(Yes),	_____	(No),	_____	(Abstained),	_____	(Absent)
Commissioner Bell	_____	(Yes),	_____	(No),	_____	(Abstained),	_____	(Absent)
Commissioner Gunter	_____	(Yes),	_____	(No),	_____	(Abstained),	_____	(Absent)
Commissioner Mobilian	_____	(Yes),	_____	(No),	_____	(Abstained),	_____	(Absent)

Approved as to form:

Anita Geraci-Carver, City Attorney

AIA[®] Document G701[™] – 2017

Change Order

PROJECT: <i>(name and address)</i> Fruitland Park Public Works 2601 Spring Lake Rd. Fruitland Park, FL 34731	CONTRACT INFORMATION: Contract For: New Construction Date: October 13, 2022	CHANGE ORDER INFORMATION: Change Order Number: 1 Date: March 16, 2023
OWNER: <i>(name and address)</i> The City of Fruitland Park 506 West Berckman St. Fruitland Park, FL 34731	ARCHITECT: <i>(name and address)</i> GatorSkitch Architects 1000 E. Hwy 50, Suite 201A Clermont, FL 34711	CONTRACTOR: <i>(name and address)</i> GSB Construction & Development, Inc. 8470 NE 44th Dr., Suite B Wildwood, FL 34785



The Contract is changed as follows:
(Insert a detailed description of the change and, if applicable, attach or reference specific exhibits. Also include agreed upon adjustments attributable to executed Construction Change Directives.)

As per GSB Construction Change Request #1

The original (Contract Sum) (Guaranteed Maximum Price) was	\$	3,234,00.00
The net change by previously authorized Change Orders	\$	0.00
The (Contract Sum) (Guaranteed Maximum Price) prior to this Change Order was	\$	3,234,000.00
The (Contract Sum) (Guaranteed Maximum Price) will be <u>increased</u> (decreased) (unchanged) by this Change Order in the amount of	\$	4,349.19
The new (Contract Sum) (Guaranteed Maximum Price), including this Change Order, will be	\$	3,238,349.19
The Contract Time will be (increased) (decreased) <u>unchanged</u> by		() days.
The new date of Substantial Completion will be		

NOTE: This Change Order does not include adjustments to the Contract Sum or Guaranteed Maximum Price, or the Contract Time, that have been authorized by Construction Change Directive until the cost and time have been agreed upon by both the Owner and Contractor, in which case a Change Order is executed to supersede the Construction Change Directive.

NOT VALID UNTIL SIGNED BY THE ARCHITECT, CONTRACTOR AND OWNER.

GatorSkitch Architects ARCHITECT <i>(Firm name)</i>  SIGNATURE Bill Gordy, CA Mgr PRINTED NAME AND TITLE 3/16/23 DATE	GSB Construction & Development, Inc. CONTRACTOR <i>(Firm name)</i>  SIGNATURE Dominic Giannini, Pres. PRINTED NAME AND TITLE 3-16-23 DATE	The City of Fruitland Park OWNER <i>(Firm name)</i> SIGNATURE PRINTED NAME AND TITLE DATE
-------------------------------------------------------------------------------------------------------------------------------------------------------------------------------------------------------------------------------	---------------------------------------------------------------------------------------------------------------------------------------------------------------------------------------------------------------------------------------------------	-------------------------------------------------------------------------------------------------------------------

CAUTION: You should sign an original AIA Contract Document, on which this text appears in RED. An original assures that changes will not be obscured.



Change Request

To: The City of Fruitland Park
506 West Berckman St.
Fruitland Park, FL 34731

Number: 1
Date: 2/24/23
Job: 22-23 Fruitland Park Public Works
Phone:

Description: RFI 001 CT Metering

We are pleased to offer the following specifications and pricing to make the following changes:

Change Request #1 is being submitted for the addition of the CT cabinet required per RFI 001 Response and the City of Leesburg Electrical requirements.

The total amount to provide this work is \$4,349.19
(Please refer to attached sheet for details.)

The schedule is not affected by this change.

If you have any questions, please contact me at 352-748-1949.

Submitted by: DOM GIANNINI

Approved by: _____
Date: _____

Change Request 1 Price Breakdown
Continuation Sheet

Description: RFI 001 CT Metering

Description	Labor	Material	Equipment	Subcontract	Other	Price
South Lake Electric Quote				\$3,953.81		\$3,953.81
					Subtotal:	\$3,953.81
			O/H/P	\$3,953.81	10.00%	\$395.38
					Total:	\$4,349.19

South Lake Electric
 P.O. Box 325
 Groveland, FL 34736

ESTIMATE

Phone #	Fax #
352-429-2624	352-429-4724

DATE
3/9/2023

NAME / ADDRESS
GSB CONSTRUCTION & DEVELOPMENT, INC. 8470 N.E.44TH DR. SUITE B WILDWOOD, FL 34785

JOB SITE
FRUITLAND PARK PUBLIC WORKS CHANGE ORDER #1

Estimate #	P.O. NO.	TERMS	DUE DATE	Job Number
2233 REV		Due on receipt	3/9/2023	C1326 COR1

ITEM	DESCRIPTION	Total
EXBC Extra's Billing Code	IN RESPONSE TO RFI 001 INSTALL (1) CT CABINET AS PER YOUR	0.00
EXBC Extra's Billing Code	REQUEST:	
EXBC Extra's Billing Code	MATERIAL:	1,599.23
	SHIPPING:	259.60
	LABOR:	1,200.00
	TAXES:	130.12
	OH/P:	764.86

	Total	\$3,953.81
--	--------------	------------

All material is guaranteed to be as specified. All work to be completed in a professional manner according to standard practices. Any alteration or deviation from above specifications involving extra costs will be executed only upon written orders and will become an extra charge over and above the proposal. All agreements contingent upon delays beyond our control. Purchaser agrees to pay all costs of collection, including attorney's fees. This proposal may be withdrawn by us if not accepted by the above due date.

Accepted By: _____

RFI

To: GATORSKETCH ARCHITECTS
1000 EAST HWY 50
SUITE 201A
CLERMONT, FL 34711

RFI #: 001
Date: 2/3/2023
Job: 22-23 Fruitland Park Public Works
Phone:

CC:

Subject: Electric Service CT Metering

Drawing: E501
Cost Impact: None

Spec Section:
Schedule Impact: None

Request:	Date Required:
Please see attached CT Metering excerpt from Leesburg Electric Department. The current riser diagram per E501 does not call for CT metering. Please provide updated riser diagram to meet requirements per City of Leesburg Electric.	
Requested by: DOM GIANNINI	

Response:	
_____	_____
Answered by	Date
_____	_____
Company	



City of Leesburg

Electric Department

“Blue Book”

Requirements for Installation of Electric Services - 2020

Excerpt: CT Metering

(Reference Pages 23-25, 53-55)

D. CURRENT TRANSFORMER INSTALLATIONS

1. The use of current transformers shall be determined by the City of Leesburg Electric Department. Three phase services over 200 amps will be CT'd, while single phase services over 320 amps will be CT'd.
2. It is very important to both the City of Leesburg Electric Department and the customer that the instructions and construction details shown in **Figures 18-20** be followed closely on all instrument transformer installations.
3. The facilities necessary for current transformer installations shall be provided and installed as described below:
 - a. The customer shall provide and install all inter-connecting raceways or conduits. All such conduits or raceways shall be a minimum of 1 ½” in diameter and a maximum of 30 feet in total length unless otherwise approved by the meter department. For installations entirely or partially below ground, 1 ½” inch minimum schedule 40 PVC conduit shall be used. For installations entirely above ground, 1 ½” minimum schedule 40 PVC or metallic Conduit may be used.

- b. The current transformers and enclosures:
 - i. The customer shall provide and install the enclosure for the current transformers. The enclosure shall be 36"x36x12" for three phase installations, and 24"x24"x12" for Single phase installations.
 - ii. The Electric Department shall provide the meter enclosure and current transformers and shall install the instruments. See **Figure 24** for instructions on picking up any metering equipment supplied by the City.
 - iii. Customer must provide 3/4 plywood backing in Current Transformer cabinets per **Figures 18-19**.
 - iv. All current transformer cabinets shall have a lockable hasp. This hasp must be capable of locking with a round lock.
 - c. The Electric Department shall provide and install the current Transformer secondary wiring and meter.
 - d. The Customer shall not terminate nor splice his conductors within the CT enclosure.
4. Instrument transformer installations are usually made by one of three means, each of which requires coordination between the Customer and the City of Leesburg Electric Department.
- a. Outdoor current transformer enclosures are normally used when the customer receives either overhead or underground service. See **Figures 18 and 19**.
 - b. Existing services, which have wall mounted or riser mounted overhead current transformer cabinets shall continue to be serviced. Additions to existing services shall be permitted, but when services are totally rebuilt, they shall be converted to outdoor wall mounted CT enclosures. When additions are made to existing services, contact an Electric Service Planner with the Electric Department for installation requirements.
 - c. Instrument transformer installations in transformer vaults and pad mounted transformers are applicable only where the number and size of secondary conductors are too many or too large to place in City of Leesburg current transformers inside wall mounted CT cabinets.

5. A clear space at least 48” from the front of all instrument transformer enclosures shall be maintained from grade to 6’6” height, minimum of 36” wide (18” on each side of center line of meter socket) to allow easy and safe access for reading and testing. This will be enforced on all existing and new installations.
6. Procedure to pick up meter can for CT installations and schedule installation of CT’s
 - a. Present warehouse personnel with electrical permit and work order number provided by a Service Planner. The warehouse is located at 2010 Griffin Road, Leesburg. Warehouse hours are from 7:00 am to 3:30 pm.
 - b. Request proper meter can (Single phase CT’d is an 8 terminal, Three phase Ct’d is a 13 terminal Meter can).
 - c. Call the meter department at 352-728-9883 a minimum of 72 hours in advance to schedule installation of Current Transformers
7. All new current installations will be wall mounted, unless prior approval is gained through the Service Planners and the Meter Department. Please consult the table below for maximum number of conductors per wall mounted CT installation.

Conductor Size									
4/0	250	300	350	400	500	600	700	750	1000
9	7	6	5	4	3	2	2	2	1
Total number of cables allowed per CT per conductor									

Conductor table for Current transformer installations

*Note: Only services that are greater than 600 AMPs (3-Phase) **AND** have a feeder schedule that exceeds the conductor size and number limits in the table above qualify for CTs to be installed in the transformer.

Example: An 800-AMP service that has a feeder schedule that calls for three sets of 3-#400 AL conductors does not exceed the maximum conductors allowed per CT.

Figure #19: Underground CT Installation

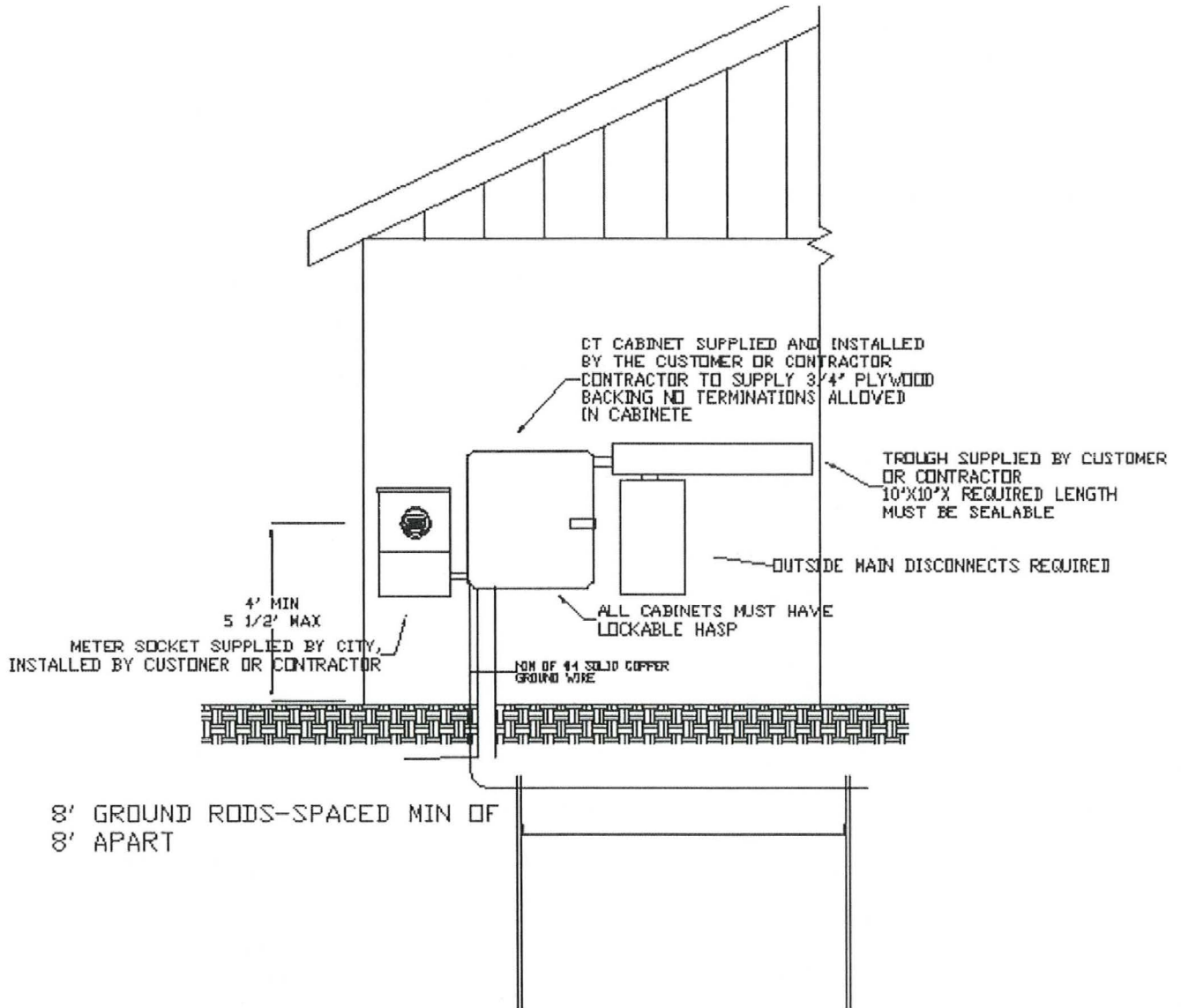

UNDERGROUND CT INSTALLATION
CT CABINETS FOR SINGLE PHASE CABINETS
ARE 24"X24"X12"
THREE PHASE CABINETS ARE
36"X36"X12"
ALL CABINETS SUPPLIED BY CONTRACTOR
ALL CABINETS TO HAVE LOCKABLE HASP
CUSTOMER TO SUPPLY 3/4" PLYWOOD BACKING.

Figure #20: Pad Mounted Transformer CT Installation

TYPICAL CT METERING
AT TRANSFORMER LOCATION
WITH NO OTHER SERVICES
FED FROM TRANSFORMER

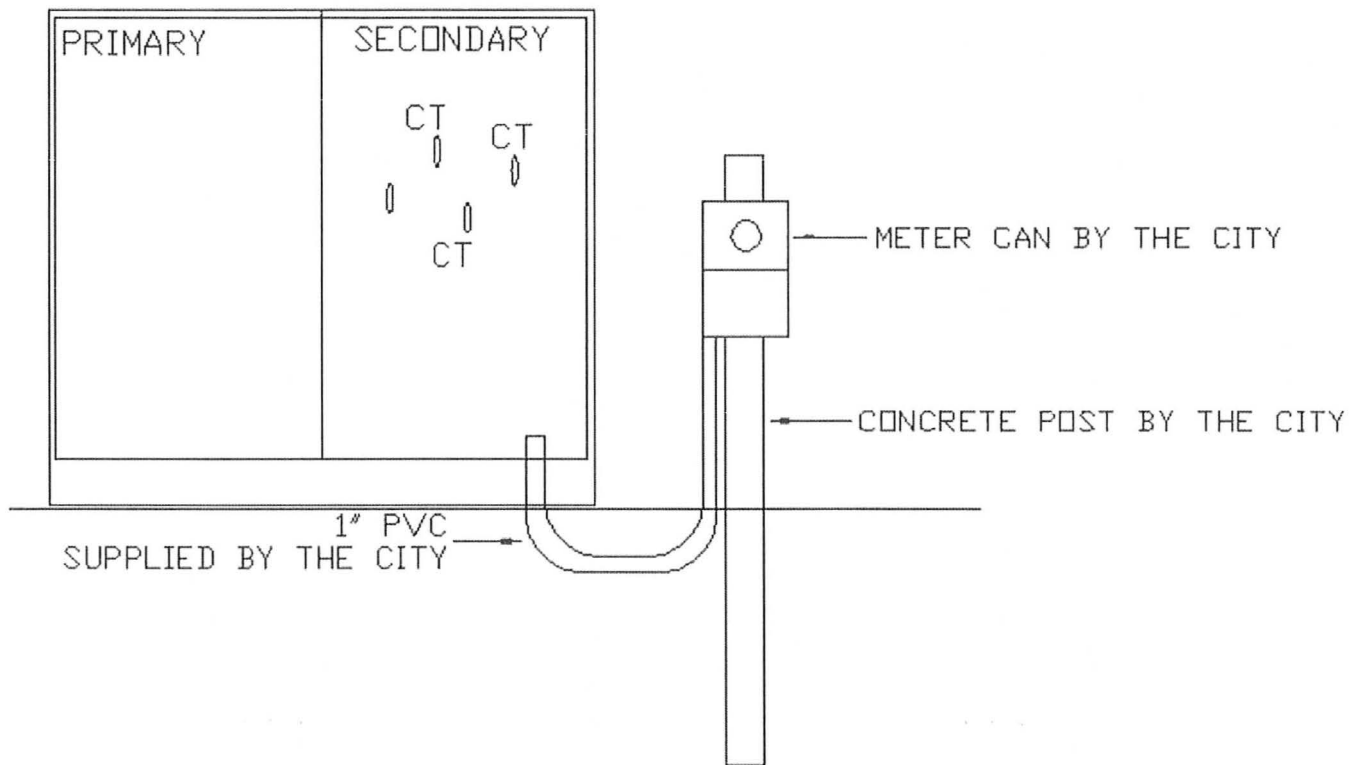

PAD MOUNTED TRANSFORMER CT INSTALLATION
CONDUCTORS TO BE SUPPLIED BY THE OWNER/CONTRACTOR
CT'S TO BE INSTALLED BY THE ELECTRIC DEPARTMENT
METER CAN PROVIDED BY THE ELECTRIC DEPARTMENT
CT METERING AT THE TRANSFORMER IS NOT NORMALLY
AVAILABLE.

EXCEPTIONS WILL BE BASED ON NUMBER AND SIZE OF CONDUCTORS
NEEDED FOR A LARGE SERVICE.



Orlando, Florida
Tampa, Florida

Miami, Florida

935 Lake Baldwin Lane
Orlando, FL 32814

Tel: 407-767-5188
Fax: 407-767-5772
sgmeng@sgmengineering.com

Letter of Transmittal

TO: Gator Sktch
100 E. Hwy 50,
Suite 210A
Clermont, FL 34711
(407) 608-5677 FAX:

PROJ #: 2021-142
PROJECT: Fruitland Park Public Works

ATTN: Bill Guidry

COPIES TO:

DATE: February 10, 2023

WE TRANSMIT: Herewith
FOR YOUR: Use
THE FOLLOWING: Shop Drawings/RFI

- Via:**
- E-mail
 - Delivery
 - Pick Up
 - Overnight
 - Second Day
 - FAX

Corrections or comments made on equipment submittals or shop drawings during this review do not relieve contractor from compliance with requirements of the drawings and specifications. This check is only for review of general conformance with the design concept of the project and general compliance with the information given in the contract documents. The contractor is responsible for: confirming and correlating all quantities and dimensions; selecting fabrication processes and techniques of construction; coordinating his work with that of all other trades and performing his work in a safe and satisfactory manner.

Submittal Item	Copies	Action	Reviewed By
RFI #1 Electric Service CT Metering	1	Responded to RFI	Scott D

*Question:
Please see attached.*

*Response:
See attached revised sheet E501 to include CT enclosure required by utility company. Ensure to follow all requirements of utility company including, but not limited to box size, lockable hasp, interior 3/4" plywood backboard, and conduit connection to meter base.*

PREPARED BY: Kelsey Kappas
Administrative Assistant

MANUFACTURER:		SQ. D.		MAIN OPTIONS REQUIRED		PANEL NAME:						
TYPE: HCM		K AMPS		MCB: 600 AMPS		MDP						
AIC RATING: 42		V		MLO: AMPS		ELEC ROOM 119						
VOLTS L-N: 120		V		S.E. RATED: YES		SURFACE						
VOLTS L-L: 208		V		GFI PROT: NO		WIDTH: 32.00 IN						
PHASE: 3		V		SHUNT TRIP: N/A		DEPTH: 8.25 IN						
NOTES	CKT NO.	IDENTIFICATION	LOAD/PHASE (KVA)			CIRCUIT BREAKER			LOAD/PHASE (KVA)			NOTES
			A	B	C	TRIP	P	TRIP	A	B	C	
	1	AHU-1-1	4.76			50	3	45	4.00			LIFT STATION
	3		4.76						4.00			
	5			4.76						4.00		
	7		4.22						3.00			
	9	AHU-1-2	4.22			45	3	60	3.00			PANEL C (FUEL STATION)
	11			4.22						3.00		
	13		3.89						3.00			
	15	DOAS-2	3.89			60	3	35	3.00			EWB-1
	17			3.89						3.00		
	19		2.56						4.00			
	21	CU-1-1	2.56			30	3	60	4.00			POLE BARN PANEL
	23			2.56						4.00		
	25		2.56						1.30			
	27	CU-1-2	2.56			30	3	20	1.30			BOOSTER PUMP BP-1
	29			2.56						1.30		
	31		0.38						14.24			
	33	CU-2	0.38			15	3	200	14.24			PANEL A
	35			0.38						14.24		
	37								18.43			
	39	SURGE PROTECTION				30	3	200	18.43			PANEL B
	41								18.43			

SUB FEED LUGS AS INDICATED, IF BLANK (NOT USED)

CONN. LOAD (KVA)	DEMAND FACTOR	DEMAND LOAD (KVA)
18.4	18.4	18.4

RECEPTACLES 1ST 10 KVA(R)	10.00	1.00	10.00
RECEPTACLES OVER 10KVA(R)	9.58	0.50	4.94
HVAC EQUIPMENT (H)	59.31	1.00	59.31
APPLIANCES (A)	0.00	1.00	0.00
EQUIPMENT (E)	113.84	1.00	113.84
LARGEST MOTOR (M)	0.00	1.25	0.00
OTHER (O)	0.00	1.00	0.00
SPARE (S)	0.00	1.00	0.00
LINKED PANEL (P)	INCLUDED IN ABOVE TOTALS		

TOTAL CONNECTED KVA: 199.01
TOTAL CONNECTED AMPS/PH: 553
TOTAL DEMAND KVA: 195.72
TOTAL DEMAND AMPS/PH: 544

GENERAL NOTES:
a. PROVIDE ARC FLASH LABELING FOR THE PANEL IN ACCORDANCE WITH NFPA 70 & 70E AS SPECIFIED.

SCHEDULE NOTES:

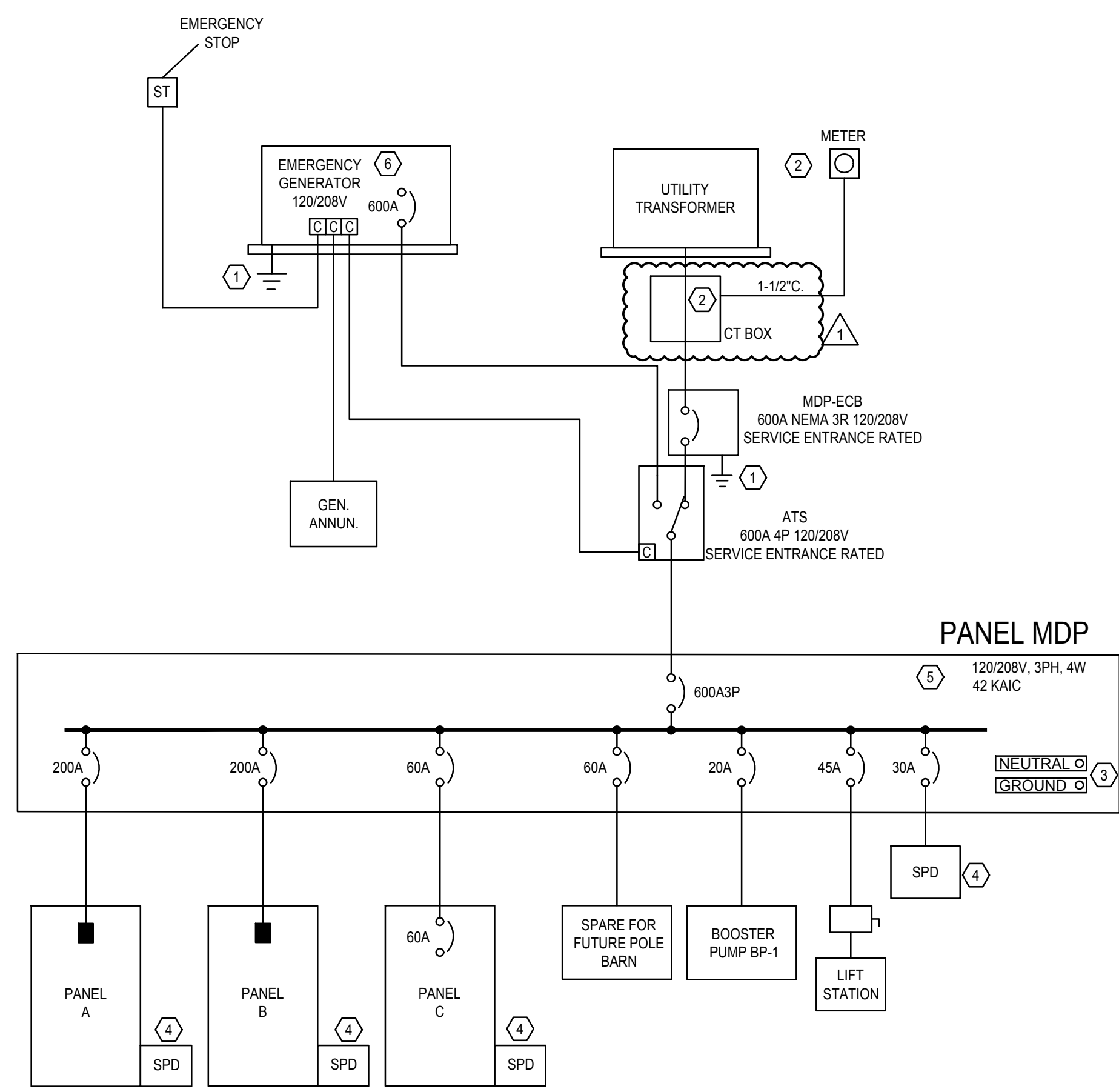

- GENERAL NOTES:**
- REFER TO SYMBOL LEGEND ON SHEET E001.
 - REFER TO BOOK SPECIFICATIONS.
 - REFER TO ARCHITECTURAL INTERIOR ELEVATIONS TO COORDINATE EXACT PLACEMENT OF ALL DEVICES, EQUIPMENT, FIXTURES, SWITCHES AND OUTLETS.
 - REFER TO EQUIPMENT SCHEDULES FOR DISCONNECT, CONDUIT AND WIRE SIZES.
 - ALL COMPUTER CIRCUITS SHALL HAVE DEDICATED NEUTRAL FROM LOAD TO SOURCE EQUIPMENT.
 - ALL FEEDERS ARE TO HAVE LESS THAN 2% TOTAL VOLTAGE DROP AND ALL BRANCH CIRCUITS SHALL HAVE LESS THAN 3% VOLTAGE DROP.
 - IF CIRCUITS ARE COMBINED AND RUN AS MULTI-WIRE BRANCH CIRCUITS SHARING A COMMON NEUTRAL, THEN EACH UNGROUNDED CONDUCTOR MUST BE DISCONNECTED SIMULTANEOUSLY BY A COMMON TRIP CIRCUIT BREAKER. CONTRACTOR MAY, AT THEIR OPTION, PROVIDE EITHER COMMON TRIP MULTI-POLE CIRCUIT BREAKERS OR UTILIZE MANUFACTURERS LISTED HANDLE TIES IN ORDER TO PROVIDE THE SIMULTANEOUS TRIP. THESE DEVICES ARE NOT SHOWN IN THE PANEL SCHEDULES AND MUST BE PROVIDED BY THIS SCOPE OF WORK. NO MORE THAN 3 CIRCUITS MAY BE COMBINED IN A SINGLE RACEWAY WITHOUT PRIOR APPROVAL BY THE ENGINEER.
 - CONTRACTOR SHALL PROVIDE ARC FLASH WARNING LABELS FOR ALL PANELS.
 - ENSURE ALL WIRES ARE TAGGED PER IDENTIFICATION SPECIFICATION.
 - ENSURE NEW PANEL HEIGHT DOES NOT RESULT IN EXCEEDING 6'-7" TO HIGHEST BREAKER.

- PLAN KEY NOTES:**
- PROVIDE GROUNDING ELECTRODE PER DETAIL.
 - COORDINATE WITH UTILITY COMPANY TO PROVIDE REQUIRED CONDUIT AND WIRE CONNECTION FOR SERVICE AND METER INSTALLATION. PROVIDE 36"x36"x12" BOX WITH HINGED COVER, LOCKABLE HASP, AND 3/4" PLYWOOD BACKING INSIDE.
 - DO NOT BOND GROUND AND NEUTRAL BUS.
 - PROVIDE SURGE PROTECTION DEVICE FOR PANEL.
 - SEE PANEL SCHEDULE FOR ALL BREAKERS REQUIRED FOR EQUIPMENT CONNECTIONS.
 - STANDBY DIESEL GENERATOR SET WITH ENCLOSURE AND FUEL TANK. 120/208V, 3 PHASE, 4 WIRE, 180KW WITH 600A BREAKER. ENCLOSURE TO BE 150 MPH RATED, 500 GAL FUEL TANK.

PANEL FEEDER SCHEDULE:

* WIRE SIZES ARE BASED ON NFPA 70 TABLE 310.15(B)(16) 60 DEGREE CU COLUMN FOR SIZES OF 100A AND LESS, ALL OTHERS BASED ON 75 DEGREE COLUMN. **LOAD AMPS AND DISTANCE SHOWN FOR VD CALCULATION ONLY. SEE PANEL SCHEDULE FOR ACTUAL LOAD. ACTUAL DISTANCE MAY VARY DEPENDENT ON ROUTING.

FEEDER DESCRIPTION	VOLTS	PH	NEUT	GRND	ISO	MAIN	OCB	LOAD	DISCONNECT SIZE	FUSE	NEMA	WIRE PER WIRE	NEUT WIRE	GND WIRE	ISO GND	SYST	# OF RUNS	CONDUIT SIZE	APPROX. DIST. FT	VOLT DROP V/D%	NOTES
UTL MDP-ECB	208	3	Y	N	N	N	N	600	480		#350	#350			#2/0	2	3"	50	0.39%		
MDP-ECB	208	3	Y	N	Y	N	N	600	480		#350	#350		#1		2	3"	20	0.16%		
GEN	208	3	Y	N	Y	N	N	600	480		#350	#350		#1		2	3"	50	0.39%		
ATS	208	3	Y	N	Y	N	N	600	480		#350	#350		#1		2	3"	10	0.08%		
MDP A	208	3	Y	N	Y	N	N	200	160		#3/0	#3/0	#6		1	2-1/2"	30	0.32%			
MDP B	208	3	Y	N	Y	N	N	200	160		#3/0	#3/0	#6		1	2-1/2"	30	0.32%			
MDP C	208	3	Y	N	Y	N	N	60	48		#2	#2	#4		1	1-1/2"	200	1.60%			

ELECTRICAL ONE-LINE DIAGRAM

EQUIPMENT FEEDER SCHEDULE:

* WIRE SIZES ARE BASED ON NFPA 70 TABLE 310.15(B)(16) 60 DEGREE CU COLUMN FOR SIZES OF 100A OR LESS, ALL OTHERS BASED ON 75 DEGREE COLUMN. **DISTANCE SHOWN FOR VOLTAGE DROP CALCULATION ONLY. ACTUAL DISTANCE MAY VARY DEPENDENT ON ROUTING.

EQUIPMENT DESCRIPTION	VOLTS	PH	NEUT	MOTOR (LARGEST)	ADDITIONAL MOTORS		HEAT STRIPS		MISC AMPS	TOTAL AMPS	MIN C.B. SIZE	P.N.L. SIZE	DISCONNECT SIZE	STARTER SIZE	WIRE PER WIRE	NEUT WIRE	GND WIRE	# OF RUNS	CONDUIT SIZE	APPROX. DIST. FT	VOLT DROP V/D%	NOTES	
					H.P.	FLA	H.P.	FLA															KW
AHU-1-1	208	3	Y	1.00	3.50				39.6	49.5	50	60	NF	1	#6	#6	#10	1	1-1/4"	50	0.81%		
AHU-1-2	208	3	Y	1.00	4.60				13.0	36.1	45	60	NF	1	#6	#6	#10	1	1-1/4"	50	0.72%		
DOAS-2	208	3	Y	5.00	16.70	2.00	7.50	4.0	11.1	12.0	47.3	54.3	60	60	NF	1	#4	#4	#10	1	1-1/2"	50	0.61%
CU-1-1	208	3	Y	5.00	16.70	1.00	4.60				21.3	25.5	30	30	NF	3R	#10	#10	#10	1	3/4"	50	1.06%
CU-1-2	208	3	Y	5.00	16.70	1.00	4.60				21.3	25.5	30	30	NF	3R	#10	#10	#10	1	3/4"	50	1.06%
CU-2	208	3	Y				3.00				3.0	3.0	15	30	NF	3R	#12	#12	#12	1	3/4"	75	0.37%
EF-1	120	1	Y		0.07						0.1	0.1	15	MMS		1	#12	#12	#12	1	3/4"	30	0.01%
EF-2	120	1	Y		0.07						0.1	0.1	15	MMS		1	#12	#12	#12	1	3/4"	30	0.01%
EF-3	120	1	Y		0.78						0.8	1.0	15	MMS		1	#12	#12	#12	1	3/4"	75	0.19%
EF-4	120	1	Y	1.00	16.00						16.0	20.0	30	MMS		1	#10	#10	#10	1	3/4"	75	2.40%
EF-5	120	1	Y	1.00	16.00						16.0	20.0	30	MMS		1	#6	#6	#6	1	1-1/4"	150	1.96%
EF-6	120	1	Y		2.60						2.6	3.3	15	MMS		1	#12	#12	#12	1	3/4"	150	1.30%
EWC	120	1	Y						8.0		8.0	8.0	15			#12	#12	#12	1	3/4"	50	1.33%	
HAND DRYER	120	1	Y		8.32						8.3	10.4	15			#12	#12	#12	1	3/4"	100	2.77%	
BW-1	208	3	Y				9.0	25.0			25.0	31.3	35	60	NF	1	#8	#8	#10	1	1"	50	0.81%
ICE MACHINE	208	1	Y		15.10						15.1	18.9	20	MMS		1	#12	#12	#12	1	3/4"	75	2.18%
CAR LIFT	208	3	Y	3.00	10.60				3.0		13.6	16.3	20	30	NF	1	#12	#12	#12	1	3/4"	75	1.70%
208 RECEPT	208	3	Y				8.3	39.9			39.9	49.9	50			1	#6	#6	#10	1	1-1/4"	130	2.44%
AIR COMPRESSOR	208	3	Y	5.00	16.70						16.7	20.9	25	30	NF	3R	#10	#10	#10	1	3/4"	150	2.50%
DRYER	208	1	Y				5.0	24.0			24.0	30.0	30			#10	#10	#10	1	3/4"	100	2.77%	
LIFT STATION	208	3	Y	5.00	16.70	5.00	16.70				33.4	37.6	45	60	NF	3R	#6	#6	#10	1	1-1/4"	150	2.04%
ENTRY GATE	208	1	N	0.50	5.40						5.4	6.8	15	30	NF	3R	#10	#10	#10	1	3/4"	450	2.80%
BOOSTER PUMP	208	3	Y	3.00	10.60				2.0		12.6	15.3	20	30	NF	#12	#12	#12	1	3/4"	50	1.05%	

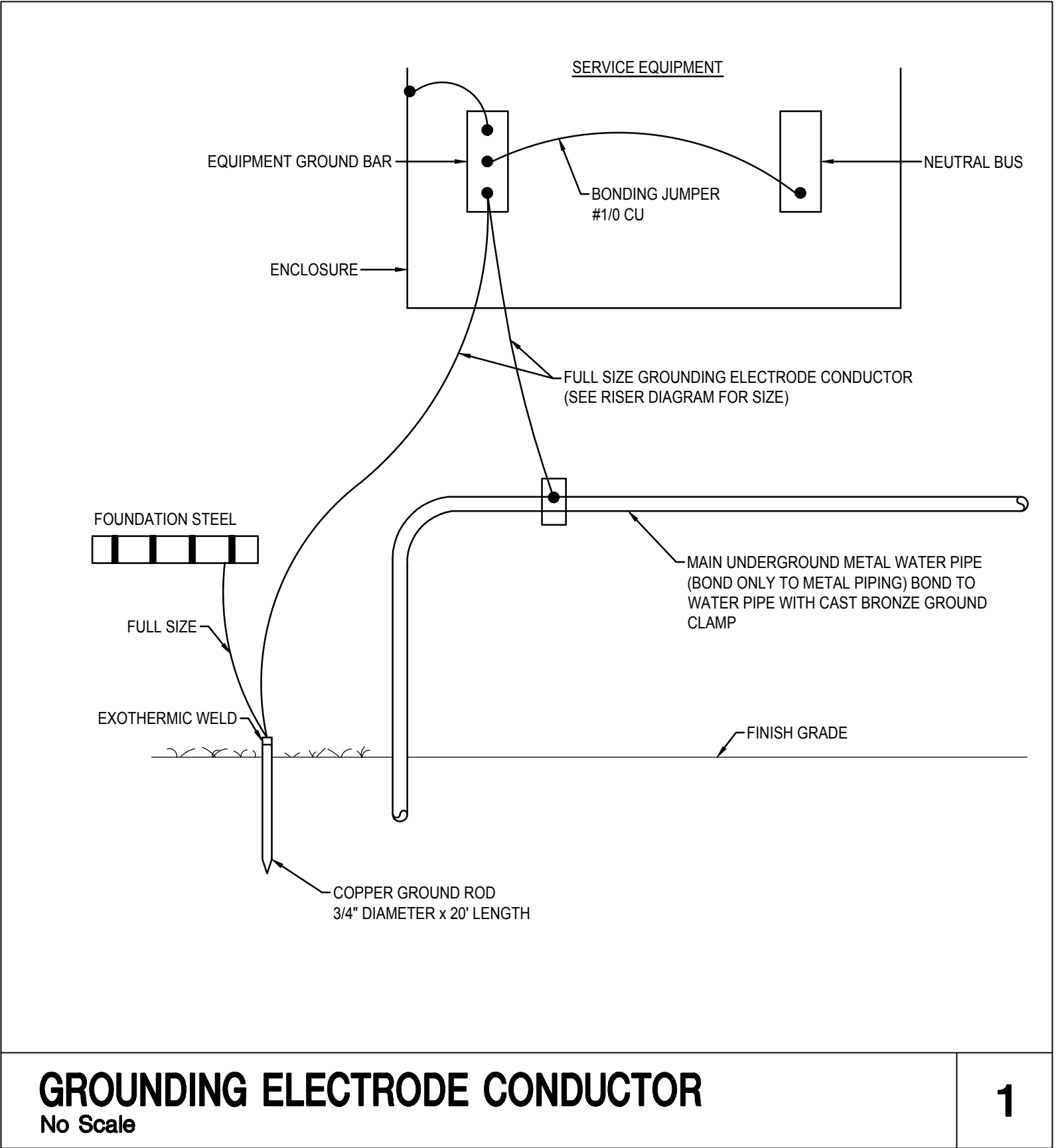

GROUNDING ELECTRODE CONDUCTOR
No Scale

This item has been electronically signed and sealed by the individual named beside, using a dated Digital Signature, per F.A.C. Rule 61G15-23.004. Printed copies of this document are not considered signed and sealed and the signature must be verified on any electronic copies.

JUSTIN L. MUNDLE
LICENSE No. 70700
STATE OF FLORIDA
PROFESSIONAL ENGINEER

SGM ENGINEERING
935 LAKE BALDWIN LANE
ORLANDO, FL 32814
TEL: 407-767-5188
FAX: 407-767-5772
CA-00006208

WWW.SGMENGINEERING.COM
SGM #: 2021-142 COPYRIGHT © 2021 SGM ENGINEERING, INC.

REVISIONS
02/09/2023
RFI# 001

FRUITLAND PARK PUBLIC WORKS
2601 SPRING LAKE ROAD
FRUITLAND PARK, FLORIDA, 34731

BID SET

GatorSketch ARCHITECTS & PLANNERS
1000 EAST HWY 66 SUITE 201A, CLEMONT, FL 34711
PH: (407) 868-5677 FAX: (888) 999-4814
Web Site: www.gatorstitch.com

CONSTRUCTION DOCUMENTS
COPYRIGHT © 2020 GATORSKETCH CORP. THIS DRAWING IS PROTECTED BY COPYRIGHT LAWS OF THE UNITED STATES. NO PART OF THIS DESIGN OR THIS DOCUMENT, INCLUDING ELECTRONIC MEDIA, MAY BE REPRODUCED, TRANSMITTED, COPIED OR OTHERWISE USED FOR CONSTRUCTION PURPOSES WITHOUT EXPRESSED WRITTEN PERMISSION OF THE DESIGN PROFESSIONAL. VIOLATORS WILL BE SUBJECT TO LEGAL PROSECUTION TO THE FULLEST EXTENT OF THE LAW.

ELECTRICAL ONE-LINE DIAGRAM
E501
ISSUE DATE 07-12-22

CITY OF FRUITLAND PARK
AGENDA ITEM SUMMARY SHEET
Item Number: 5d

ITEM TITLE: Resolution 2023-022 Change Order 2, CR 02 PVC Pipe Credit for New Public Works Building

MEETING DATE: Thursday, March 23, 2023

DATE SUBMITTED: Friday, March 13, 2023

SUBMITTED BY: City Attorney/City Manager/Public Works Director

BRIEF NARRATIVE: Resolution 2023-022 – The city awarded and entered into a EJCDC Standard Form of Agreement (ITB 2022-01) with GSB Construction and Development Inc. on October 13, 2022.

This is a deductive change order for the city’s new public works building located at 2601 Spring Lake Road, Fruitland Park, Florida. Change order #2 reduces the contract price with GSB Construction by \$8,000.00 due to changing the overhead cast iron sanitary pipe to Sch. 40 PVC pipe and changing overhead copper domestic water pipe to CPVC pipe.

The public works director requested this change as a cost savings to the city. Staff is of the opinion that the PVC pipe will last longer as it is resistant to chemicals and the CPVC water pipe will do the same job as the copper water pipe. Both products are almost standard products in the industry on commercial projects and represents cost savings to both the copper and cast iron that was specified.

FUNDS REQUIRED: Deduction of \$8,000 in the change order to the contract price with GSB Construction and Development Inc. (Capital – 30541-60620)

ATTACHMENTS: Proposed Resolution 2023-022, change order request #2 from GSB Construction, and A1A Document G701

RECOMMENDATION: Staff recommends approval.

ACTION: Adopt Resolution 2023-022

RESOLUTION 2023-022

A RESOLUTION OF THE CITY COMMISSION OF THE CITY OF FRUITLAND PARK, FLORIDA, APPROVING CHANGE ORDER NO. 2 TO THE EJCDC STANDARD FORM OF AGREEMENT BETWEEN OWNER AND CONTRACTOR ON THE BASIS OF A STIPULATED PRICE BETWEEN THE CITY OF FRUITLAND PARK AND GSB CONSTRUCTION & DEVELOPMENT, INC. TO PROVIDE FOR A REDUCTION OF \$8,000.00 IN THE STIPULATED SUM; AUTHORIZING THE CITY MANAGER TO EXECUTE THE CHANGE ORDER; PROVIDING FOR AN EFFECTIVE DATE.

WHEREAS, the City of Fruitland Park issued Invitation to Bid No. 2022-01 for construction of the city’s public works building and entered into that certain contract titled EJCDC Standard Form of Agreement between owner and contractor on the basis of a stipulated price between the City of Fruitland Park and GSB Construction & Development Inc. (the “Contract”); and

WHEREAS, the city requested substitution of copper water piping to CPVC and cast iron sewer piping to PVC thereby resulting in a cost-savings to the city of \$8,000.00; therefore it is necessary to decrease the Stipulated Sum by \$8,000.00; and

WHEREAS, the City Commission of the City of Fruitland Park, Florida finds it is in the best interest of the City to approve Change Order No. 2.

NOW, THEREFORE, BE IT RESOLVED AS FOLLOWS:

Section 1. The stipulated sum set forth in the contract is decreased by \$8,000.00.

Section 2. The commission authorizes the city manager to execute any required approval of such extension including Change Order No. 2, a copy of which is attached hereto.

Section 3. This resolution shall take effect immediately upon its final adoption by the City Commission of the City of Fruitland Park, Florida.

PASSED AND RESOLVED this 23rd day of March 2023, by the City Commission of the City of Fruitland Park, Florida.

SEAL

CITY COMMISSION OF THE CITY OF FRUITLAND PARK, FLORIDA

CHRIS CHESHIRE, MAYOR

ATTEST:

ESTHER COULSON, CITY CLERK, MMC

Mayor Cheshire	_____	(Yes),	_____	(No),	_____	(Abstained),	_____	(Absent)
Vice Mayor DeGrave	_____	(Yes),	_____	(No),	_____	(Abstained),	_____	(Absent)
Commissioner Bell	_____	(Yes),	_____	(No),	_____	(Abstained),	_____	(Absent)
Commissioner Gunter	_____	(Yes),	_____	(No),	_____	(Abstained),	_____	(Absent)
Commissioner Mobilian	_____	(Yes),	_____	(No),	_____	(Abstained),	_____	(Absent)

Approved as to form:

Anita Geraci-Carver, City Attorney



AIA Document G701™ – 2017

Change Order

PROJECT: *(name and address)*
 Fruitland Park Public Works
 2601 Spring Lake Rd.
 Fruitland Park, FL 34731

CONTRACT INFORMATION:
 Contract For: New Construction
 Date: October 13, 2022

CHANGE ORDER INFORMATION:
 Change Order Number: 2
 Date: March 16, 2023

OWNER: *(name and address)*
 The City of Fruitland Park
 506 West Berckman St.
 Fruitland Park, FL 34731

ARCHITECT: *(name and address)*
 GatorSketch Architects
 1000 E. Hwy 50, Suite 201A
 Clermont, FL 34711

CONTRACTOR: *(name and address)*
 GSB Construction & Development, Inc.
 8470 NE 44th Dr., Suite B
 Wildwood, FL 34785

The Contract is changed as follows:

(Insert a detailed description of the change and, if applicable, attach or reference specific exhibits. Also include agreed upon adjustments attributable to executed Construction Change Directives.)

As per GSB Construction Change Request #2

The original (Contract Sum) (Guaranteed Maximum Price) was	\$	3,234,00.00
The net change by previously authorized Change Orders	\$	4,349.19
The (Contract Sum) (Guaranteed Maximum Price) prior to this Change Order was	\$	3,238,349.19
The (Contract Sum) (Guaranteed Maximum Price) will be (increased) (<u>decreased</u>) (unchanged) by this Change Order in the amount of	\$	8,000.00
The new (Contract Sum) (Guaranteed Maximum Price), including this Change Order, will be	\$	3,230,349.19
The Contract Time will be (increased) (decreased) (<u>unchanged</u>) by		() days.
The new date of Substantial Completion will be		

NOTE: This Change Order does not include adjustments to the Contract Sum or Guaranteed Maximum Price, or the Contract Time, that have been authorized by Construction Change Directive until the cost and time have been agreed upon by both the Owner and Contractor, in which case a Change Order is executed to supersede the Construction Change Directive.

NOT VALID UNTIL SIGNED BY THE ARCHITECT, CONTRACTOR AND OWNER.

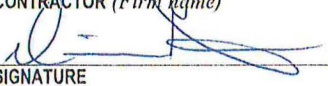
<p>GatorSketch Architects ARCHITECT <i>(Firm name)</i></p> <p> SIGNATURE</p> <p>Bill Cardry, CA MA PRINTED NAME AND TITLE</p> <p>3/16/23 DATE</p>	<p>GSB Construction & Development, Inc. CONTRACTOR <i>(Firm name)</i></p> <p> SIGNATURE</p> <p>Dominic Giannini, Pres. PRINTED NAME AND TITLE</p> <p>3-16-23 DATE</p>	<p>The City of Fruitland Park OWNER <i>(Firm name)</i></p> <p> SIGNATURE</p> <p> PRINTED NAME AND TITLE</p> <p> DATE</p>
------------------------------------------------------------------------------------------------------------------------------------------------------------------------------------------------------------------------------------------------------------------------------------------	------------------------------------------------------------------------------------------------------------------------------------------------------------------------------------------------------------------------------------------------------------------------------------------------------------------	------------------------------------------------------------------------------------------------------------------------------------------------------------------------------

CAUTION: You should sign an original AIA Contract Document, on which this text appears in RED. An original assures that changes will not be obscured.

Change Request

To: The City of Fruitland Park
506 West Berckman St.
Fruitland Park, FL 34731

Number: 2
Date: 2/24/23
Job: 22-23 Fruitland Park Public Works
Phone:

Description: Substitution Request - Water/Sewer Piping

We are pleased to offer the following specifications and pricing to make the following changes:

Change Request #2 is being submitted for the substitution of copper water piping to CPVC and cast iron sewer piping to PVC per Substitution Request #02

The total amount to provide this work is \$-8,000.00
(Please refer to attached sheet for details.)

The schedule is not affected by this change.

If you have any questions, please contact me at 352-748-1949.

Submitted by: DOM GIANNINI

Approved by: _____
Date: _____

Change Request 2 Price Breakdown
Continuation Sheet

Description: Substitution Request - Water/Sewer Piping

Description	Labor	Material	Equipment	Subcontract	Other	Price
Quote per Southern Plumbing				\$-7,272.73		\$-7,272.73
					Subtotal:	\$-7,272.73
			OHP	-\$7,272.73	10.00%	\$-727.27
					Total:	\$-8,000.00

EXHIBIT A

CONTRACTOR'S REQUEST FOR SUBSTITUTION FORM

The undersigned hereby submits for consideration the following request for substitution in lieu of the specified item noted:

Section/Page	Paragraph/Detail	Specified Item/Model No.
<u>22 11 16</u>	<u>2.2 A/B</u>	<u>Copper Tube & Fittings</u>
<u>22 13 16</u>	<u>2.2/2,3</u>	<u>Cast Iron Soil Pipe & Fittings</u>

Proposed Substitution:

Alternate Means/Methods: CPVC for Water Piping and PVC for Sanitary Piping

REV 1 ~~PVC drain, waste & vent pipe will be installed per code with proper vertical & horizontal support
CPVC water piping will be installed per code with proper supports. CPVC to be Flow Guard Gold CPVC pipe. Service
coming into building will be copper and transition to CPVC above slab within Mech Room. Souix Chief hammer
arrestors will be installed for each fixture group~~

It is the Contractor's responsibility to provide all information necessary to determine the proposed substitution is equal or better than the specified item. Complete product description, drawings, photographs, performance and test data, samples and other information necessary for evaluation of requested substitution is to be attached and marked for comparison purposes. Fill in ALL BLANKS below.

1. Identify specific reason why this Substitution Request is being made. _____

Cost savings suggestion

2. Identify the recycled materials or components, or the features which support its status as "Environmentally Friendly": _____

N/A

3. Will approval of the requested substitution affect dimensions, locations, or configurations shown on the drawings in any way? Yes ___ No x. If "Yes", explain:

4. Will changes be required to the building or other construction in order to properly install or accommodate the requested substitution? Yes___ No x. If "Yes", explain: _____

City of Fruitland Park
Public Works Building

5. Will the Contractor pay for any changes to the building design, including re-design, engineering and detailing caused by acceptance of the substitution request? Yes__ No X. If "No", explain: _____
No redesign/engineering anticipated or required

6. Does the requested substitution meet all applicable Codes, Ordinances, and regulations for this specific application? Yes X No __. If "No", explain: _____

7. Does the requested substitution meet the same applicable standards (ASTM, ANSI, UL, FS, etc.)? Yes X No __. If "No", explain: _____

8. Will approval of the requested substitution affect the work of other trades? Yes x No __. If "Yes", explain: _____
Coordination will be handled by GSB to ensure no issues arise with other trades

9. Will the requested substitution affect the construction progress schedule? Yes__ No X. If "Yes", explain: _____

10. Has the requested substitution been used locally in similar applications? Yes X (identify) No __. (explain): _____
Many buildings within the area use CPVC for water piping and PVC for San

11. Does the manufacturer's warranty on the requested substitution differ from that specified? Yes__ No X. If "Yes", explain: _____

12. Identify monetary credit and reduction of contract time the Owner will realize if this Substitution Request is accepted. _____
Cost Savings of of ~~\$9,000.00~~ is proposed
\$8,000.00 REV 1

The Architect and Owner will not be required to prove any product is not equal or suitable for the Project.

CONTRACTOR'S CERTIFICATION OF EQUAL PERFORMANCE AND ASSUMPTION OF LIABILITY FOR EQUAL PERFORMANCE

The undersigned Contractor states that the performance, function, quality and durability are equivalent or superior to the specified item. If Contractor is a corporation, the legal name of the corporation shall be set forth below, together with signature(s) of the officer or officers authorized to sign contracts on behalf of the corporation and corporate seal; if Contractor is a partnership, the true name of the firm and the name(s) of the general partner(s) shall be set forth below with the signature(s) of the partner or partners authorized to sign contracts on behalf of the partnership.; and if the Contractor is an individual, his signature shall be placed below. Failure to provide legally binding signature(s) will result in non-consideration of Substitution Request.

Submitted By: _____ (Corporate Seal)
_____ Attest (if Corporation)

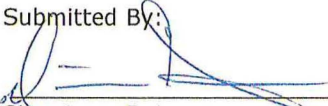
 1/3/23
Signature, Date
Dominic Giannini
Name (Print)
President
Title
GSB Construction & Development, Inc
Primary GC Firm (Print)
8470 NE 44th Dr. Suite B
Street Address
Wildwood, FL 34785
City, State, Zip
Witnesses: _____
(if partnership or individual)

ARCHITECT'S ACTION

Approved By:  Date: 3/16/23
(Signature Required)
Gregor Skitch
(Print Firm Name)
 Not Approved: By: _____ Date: _____
(Signature Required)
(Print Firm Name)

BUILDING CODE OFFICIAL ACTION

Review and approval required _____ Not Applicable (N/A) _____
 Approved By: _____ Date: _____
(Signature Required) - Building Code Official
 Not Approved By: _____ Date: _____
(Signature Required) - Building Code Official

CITY OF FRUITLAND PARK / OWNER

Approved: By: _____ Date: _____
(Signature Required) - OWNER
 Not Approved: By: _____ Date: _____
(Signature Required) - OWNER

Southern Plumbing of Ocala, Inc.

Ph: (352) 629-2747 Fax: (352)629-6336 St. Lic.CF-C057587
1717 N.W. 58 Lane Ocala, FL. 34475

Company: GSB

Date: 1.2.23

To: Dominic Giannini

From: Chris Redd

Reference Fruitland Park Public Works

Comment:

Proposal to provide and install the following;

Substitute Domestic water piping from copper to CPVC (Flow Guard Gold

Substitute Sanitary piping from Cast Iron to PVC

Sioux Chief Hammer Arrestors to be installed for each fixture group

Credit _____ \$7,272.73

Thank you

Chris Redd



CITY OF FRUITLAND PARK
AGENDA ITEM SUMMARY SHEET
Item Number: 5e

ITEM TITLE: Resolution 2023-023 Change Order #3 Fire Sprinkler System – GSB Construction and Development Inc.

MEETING DATE: Thursday, March 23, 2023

DATE SUBMITTED: Friday, March 17, 2023

SUBMITTED BY: City Attorney/City Manager/Public Works Director

BRIEF NARRATIVE: Resolution 2023-023 – This is a deductive change order to the city’s new public works building located at 2601 Spring Lake Road- Fruitland Park, Florida. This change order reduces the contract price with GSB Construction by \$18,450.00 by changing the fire sprinkler system from a wet system to a dry system.

A wet system keeps water on the entire system at all times while the dry system involves the system being maintained under air pressure at all times while releasing water to the system under a loss of pressure on the system.

Staff is of the understanding that this is the cost savings resulting from not having to install a heat trace system that is required on the wet system due to the pipes being exposed in an open bay area. Staff’s communications with the contractor and his discussion with his subcontractor confirm that there is no increased maintenance cost from one system to the other.

FUNDS REQUIRED: \$18,450 (deduction) (Capital – 30541-60620)

ATTACHMENTS: Proposed Resolution 2023-023, change order request #3, GSB Construction

RECOMMENDATION: Staff recommends approval

ACTION: Adopt Resolution 2023-023

RESOLUTION 2023-023

A RESOLUTION OF THE CITY COMMISSION OF THE CITY OF FRUITLAND PARK, FLORIDA, APPROVING CHANGE ORDER NO. 3 TO THE EJCDC STANDARD FORM OF AGREEMENT BETWEEN OWNER AND CONTRACTOR ON THE BASIS OF A STIPULATED PRICE BETWEEN THE CITY OF FRUITLAND PARK AND GSB CONSTRUCTION & DEVELOPMENT, INC. TO PROVIDE FOR A DECREASE OF \$18,450.00 IN THE STIPULATED SUM; AUTHORIZING THE CITY MANAGER TO EXECUTE THE CHANGE ORDER; PROVIDING FOR AN EFFECTIVE DATE.

WHEREAS, the City of Fruitland Park issued Invitation to Bid No. 2022-01 for construction of the City’s public works building and entered into that certain contract titled EJCDC Standard Form of Agreement between Owner and Contractor on the Basis of a Stipulated Price between the City of Fruitland Park and GSB Construction & Development Inc. (the “Contract”); and

WHEREAS, the City requested the fire sprinkler system change from a wet system to a dry system thereby resulting in a cost-savings to the City of \$18,450.00; therefore it is necessary to decrease the Stipulated Sum by \$18,450.00; and

WHEREAS, the City Commission of the City of Fruitland Park, Florida finds it is in the best interest of the City to approve Change Order No. 3.

NOW, THEREFORE, BE IT RESOLVED AS FOLLOWS:

Section 1. The Stipulated Sum set forth in the Contract is decreased by \$18,450.00.

Section 2. The Commission authorizes the city manager to execute any required approval of such extension including Change Order No. 3, a copy of which is attached hereto.

Section 3. This resolution shall take effect immediately upon its final adoption by the City Commission of the City of Fruitland Park, Florida.

PASSED AND RESOLVED this 23rd day of March, 2023, by the City Commission of the City of Fruitland Park, Florida.

SEAL

CITY COMMISSION OF THE CITY OF FRUITLAND PARK, FLORIDA

CHRIS CHESHIRE, MAYOR

ATTEST:

ESTHER COULSON, CITY CLERK

Mayor Cheshire	_____	(Yes),	_____	(No),	_____	(Abstained),	_____	(Absent)
Vice Mayor DeGrave	_____	(Yes),	_____	(No),	_____	(Abstained),	_____	(Absent)
Commissioner Bell	_____	(Yes),	_____	(No),	_____	(Abstained),	_____	(Absent)
Commissioner Gunter	_____	(Yes),	_____	(No),	_____	(Abstained),	_____	(Absent)
Commissioner Mobilian	_____	(Yes),	_____	(No),	_____	(Abstained),	_____	(Absent)

Approved as to form:

Anita Geraci-Carver, City Attorney



AIA[®] Document G701[™] – 2017

Change Order

PROJECT: <i>(name and address)</i> Fruitland Park Public Works 2601 Spring Lake Rd. Fruitland Park, FL 34731	CONTRACT INFORMATION: Contract For: New Construction Date: October 13, 2022	CHANGE ORDER INFORMATION: Change Order Number: 3 Date: March 16, 2023
OWNER: <i>(name and address)</i> The City of Fruitland Park 506 West Berckman St. Fruitland Park, FL 34731	ARCHITECT: <i>(name and address)</i> GatorSketch Architects 1000 E. Hwy 50, Suite 201A Clermont, FL 34711	CONTRACTOR: <i>(name and address)</i> GSB Construction & Development, Inc. 8470 NE 44th Dr., Suite B Wildwood, FL 34785

The Contract is changed as follows:

(Insert a detailed description of the change and, if applicable, attach or reference specific exhibits. Also include agreed upon adjustments attributable to executed Construction Change Directives.)

As per GSB Construction Change Request #3

The original (Contract Sum) (Guaranteed Maximum Price) was	\$ 3,234,00.00
The net change by previously authorized Change Orders	\$ (3,650.81)
The (Contract Sum) (Guaranteed Maximum Price) prior to this Change Order was	\$ 3,230,349.19
The (Contract Sum) (Guaranteed Maximum Price) will be (increased) <u>(decreased)</u> (unchanged) by this Change Order in the amount of	\$ 18,450.00
The new (Contract Sum) (Guaranteed Maximum Price), including this Change Order, will be	\$ 3,211,899.19
The Contract Time will be (increased) (decreased) <u>(unchanged)</u> by	() days.
The new date of Substantial Completion will be	

NOTE: This Change Order does not include adjustments to the Contract Sum or Guaranteed Maximum Price, or the Contract Time, that have been authorized by Construction Change Directive until the cost and time have been agreed upon by both the Owner and Contractor, in which case a Change Order is executed to supersede the Construction Change Directive.

NOT VALID UNTIL SIGNED BY THE ARCHITECT, CONTRACTOR AND OWNER.

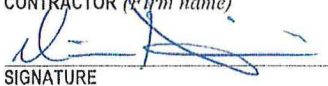
GatorSketch Architects	GSB Construction & Development, Inc.	The City of Fruitland Park
ARCHITECT <i>(Firm name)</i>	CONTRACTOR <i>(Firm name)</i>	OWNER <i>(Firm name)</i>
		
SIGNATURE	SIGNATURE	SIGNATURE
William Gurdy, CA Mgr	Dominic Giannini, Pres.	
PRINTED NAME AND TITLE	PRINTED NAME AND TITLE	PRINTED NAME AND TITLE
3/16/23	3-16-23	
DATE	DATE	DATE

CAUTION: You should sign an original AIA Contract Document, on which this text appears in RED. An original assures that changes will not be obscured.

Change Request

To: The City of Fruitland Park
506 West Berckman St.
Fruitland Park, FL 34731

Number: 3
Date: 3/15/23
Job: 22-23 Fruitland Park Public Works
Phone:

Description: Dry Sprinkler VE

We are pleased to offer the following specifications and pricing to make the following changes:

Change Request #3 is being submitted for the substitution for a dry pipe sprinkler system in lieu of heat tracing called for in contract documents.

The total amount to provide this work is \$-18,450.00
(Please refer to attached sheet for details.)

The schedule is not affected by this change.

If you have any questions, please contact me at 352-748-1949.

Submitted by: DOM GIANNINI

Approved by: _____
Date: _____



Change Request 3 Price Breakdown
 Continuation Sheet

Description: Dry Sprinkler VE

Description	Labor	Material	Equipment	Subcontract	Other	Price
Dry System VE				\$-16,772.73		\$-16,772.73
					Subtotal:	\$-16,772.73
			OH/P	-\$16,772.73	10.00%	\$-1,677.27
					Total:	\$-18,450.00



4145 County Road 561
 Tavares, FL 32778-9371
 352-639-4119
 Chris Whigham
 CWhigham@elitefirefl.com

Customer	Service Location
Elite Fire Protection US	Fruitland Park Public Works Fruitland Park, FL

Item(s)						
Qty	Name	Description	Rate	Amount	Tax	Approved
1	New Install starting 1' AFF.	New install starting 1'-0' above finished floor			NON	Yes
1	Alternate Price	Deduct price to include Dry System in place of Heat Trace	\$16,772.73	\$16,772.73	NON	No

Subtotal		
Tax		\$0.00
Total		

Notes

New install new Wet system starting 1'-0" above finished floor. Includes Design, Permit, Materials, and Labor. Layout based on plans by GayorSkitch Arch. dated 7/12/22.

Alternate Price 1 to use Dry Valve in place of Heat Trace

Excludes:
 Underground Feed
 Water Quality
 Backflow

EXHIBIT A

CONTRACTOR'S REQUEST FOR SUBSTITUTION FORM

The undersigned hereby submits for consideration the following request for substitution in lieu of the specified item noted:

Section/Page	Paragraph/Detail	Specified Item/Model No.
<u>F201</u>	<u>Fire Protection Floor Plan</u>	<u>Heat Tracing for Shop Area</u>
_____	_____	_____

Proposed Substitution:

Alternate Means/Methods: Dry Pipe System for Unconditioned Shop Area

It is the Contractor's responsibility to provide all information necessary to determine the proposed substitution is equal or better than the specified item. Complete product description, drawings, photographs, performance and test data, samples and other information necessary for evaluation of requested substitution is to be attached and marked for comparison purposes. Fill in ALL BLANKS below.

1. Identify specific reason why this Substitution Request is being made. _____
Cost savings suggestion

2. Identify the recycled materials or components, or the features which support its status as "Environmentally Friendly": _____
N/A

3. Will approval of the requested substitution affect dimensions, locations, or configurations shown on the drawings in any way? Yes X No __. If "Yes", explain:
Dry system compressor would be required within Mechanical Room 118

4. Will changes be required to the building or other construction in order to properly install or accommodate the requested substitution? Yes X No __. If "Yes", explain: _____
Electrical requirements will be coordinated to accommodate the dry system

City of Fruitland Park
Public Works Building

5. Will the Contractor pay for any changes to the building design, including re-design, engineering and detailing caused by acceptance of the substitution request? Yes__ No X. If "No", explain: _____
Design to be handled by fire sprinkler contractor
6. Does the requested substitution meet all applicable Codes, Ordinances, and regulations for this specific application? Yes X No___. If "No", explain: _____
7. Does the requested substitution meet the same applicable standards (ASTM, ANSI, UL, FS, etc.)? Yes X No___. If "No", explain: _____
8. Will approval of the requested substitution affect the work of other trades? Yes x No___. If "Yes", explain: _____
Coordination will be handled by GSB to ensure no issues arise with other trades
9. Will the requested substitution affect the construction progress schedule? Yes__ No X. If "Yes", explain: _____
10. Has the requested substitution been used locally in similar applications? Yes X (Identify) No___. (explain): _____
Many buildings within the area use dry systems for exterior portions of buildings or unconditioned spaces
11. Does the manufacturer's warranty on the requested substitution differ from that specified? Yes__ No x. If "Yes", explain: _____
12. Identify monetary credit and reduction of contract time the Owner will realize if this Substitution Request is accepted. _____
Cost Savings of of \$18,450.00 is proposed

The Architect and Owner will not be required to prove any product is not equal or suitable for the Project.

City of Fruitland Park
Public Works Building

CONTRACTOR'S CERTIFICATION OF EQUAL PERFORMANCE AND ASSUMPTION OF LIABILITY FOR EQUAL PERFORMANCE

The undersigned Contractor states that the performance, function, quality and durability are equivalent or superior to the specified item. If Contractor is a corporation, the legal name of the corporation shall be set forth below, together with signature(s) of the officer or officers authorized to sign contracts on behalf of the corporation and corporate seal; If Contractor is a partnership, the true name of the firm and the name(s) of the general partner(s) shall be set forth below with the signature(s) of the partner or partners authorized to sign contracts on behalf of the partnership.; and if the Contractor is an Individual, his signature shall be placed below. Failure to provide legally binding signature(s) will result in non-consideration of Substitution Request.

Submitted By: _____

(Corporate Seal)

Attest (If Corporation)

 1/3/23

Signature, Date

Dominic Giannini

Name (Print)
President

Title
GSB Construction & Development, Inc

Primary GC Firm (Print)
8470 NE 44th Dr. Suite B

Street Address
Wildwood, FL 34785

City, State, Zip

Witnesses: _____
(If partnership or Individual)

ARCHITECT'S ACTION

Approved By:  Date: 3/16/23

(Signature Required)



(Print Firm Name)

Not Approved: By: _____ Date: _____
(Signature Required)

(Print Firm Name)

BUILDING CODE OFFICIAL ACTION

Review and approval required _____ Not Applicable (N/A) _____

Approved By: _____ Date: _____
(Signature Required) - Building Code Official

Not Approved By: _____ Date: _____
(Signature Required) - Building Code Official

CITY OF FRUITLAND PARK / OWNER

Approved: By: _____ Date: _____
(Signature Required) - OWNER

Not Approved: By: _____ Date: _____
(Signature Required) - OWNER

CITY OF FRUITLAND PARK
AGENDA ITEM SUMMARY SHEET
Item Number: 5f

ITEM TITLE: Second Reading and Public Hearing - Ordinance 2023-001 Annexation - South of Urick Street and West of Thomas Avenue - Petitioner: Kimaya, LLC

MEETING DATE: Thursday, March 23, 2023

DATE SUBMITTED: Friday, February 24, 2023

SUBMITTED BY: City Attorney/City Manager/Community Development

BRIEF NARRATIVE: Ordinance 2023-001 Annexation to receive city services and develop a proposed subdivision including single family cottages, townhomes, and multi-family apartments.

FUNDS BUDGETED: None

ATTACHMENTS: Proposed Ordinance 2023-001, legal description, map, staff report and advertising affidavit.

RECOMMENDATION: It is highly recommended that a conceptual plan be submitted with the rezoning to R-10 and that adequate schools' determination or school concurrency reservation be submitted. The Planning and Zoning Board recommended approval at its January 19, 2023 meeting. (First reading was held on March 9, 2023.)

ACTION:

ORDINANCE 2023 - 001

AN ORDINANCE OF THE CITY COMMISSION OF THE CITY OF FRUITLAND PARK, FLORIDA, AMENDING THE BOUNDARIES OF THE CITY OF FRUITLAND PARK FLORIDA, IN ACCORDANCE WITH THE PROCEDURE SET FORTH IN SECTION 171.044, FLORIDA STATUTES, TO INCLUDE WITHIN THE CITY LIMITS APPROXIMATELY 19.10 ± ACRES OF LAND GENERALLY LOCATED SOUTH OF URICK STREET AND WEST OF THOMAS AVENUE; DIRECTING THE CITY MANAGER TO PROVIDE CERTIFIED COPIES OF THIS ORDINANCE AFTER APPROVAL TO THE CLERK OF THE CIRCUIT COURT, THE LAKE COUNTY MANAGER AND THE DEPARTMENT OF STATE OF THE STATE OF FLORIDA; PROVIDING FOR SCRIVENER'S ERRORS, SEVERABILITY AND CONFLICTS; PROVIDING FOR AN EFFECTIVE DATE.

WHEREAS, a petition has been submitted by Vishaal Gupta, as Applicant, on behalf of Kimaya, LLC, Owner, requesting that approximately 19.10 ± acres of real property generally located south of Urick Street and west of Thomas Avenue (the "Property") be annexed to and made a part of the City of Fruitland Park; and

WHEREAS, the petition bears the signature of all applicable parties; and

WHEREAS, this Ordinance has been advertised as required by law with a copy of said notice sent via certified mail to the Board of County Commissioners of Lake County as provided for by statute; and

WHEREAS, the Planning and Zoning Board considered this ordinance at a public meeting; and

WHEREAS, the Property is contiguous to the City limits and is reasonably compact; and

WHEREAS, the City Commission has determined that the area proposed for annexation meets the requirements of §171.044, Florida Statutes; and

NOW, THEREFORE, BE IT ORDAINED by the City Commission of the City of Fruitland Park, Florida, as follows:

Section 1. The recitals set forth above are hereby adopted as legislative findings of the City Commission of the City of Fruitland Park.

Section 2. The following described property consisting of approximately 19.10 acres of land generally located south of Urick Street and west of Thomas Avenue, contiguous to the City limits, is hereby incorporated into and made part of the City of Fruitland Park Florida. The property is more particularly described as follows:

LEGAL DESCRIPTION: See attached Exhibit A.

Parcel Alternate Key No. 1289891

Section 3. Upon this Ordinance becoming effective, the property annexed shall be subject to all laws, ordinances, and regulations enforced in the City of Fruitland Park, and shall be entitled to the same privileges and benefits as other parts of the City of Fruitland Park upon the effective date of the annexation. Except that the property annexed in this Ordinance is subject to the Land Use Plan

of the Lake County Comprehensive Plan and county zoning regulations until the City adopts the Comprehensive Plan Amendments to include the property annexed in the City Comprehensive Plan.

Section 4. The City Clerk shall forward a certified copy of this Ordinance to the Clerk of the Circuit Court, the County Manager of Lake County, Florida, and the Department of State of Florida within seven (7) days after its passage on second and final reading. It shall further be submitted to the Office of Economic and Demographic Research within 30 days of approval along with a statement specifying the population census effect and the affected land area. F.S. 171.091, Florida Statutes.

Section 5. Scrivener’s errors in the legal description may be corrected without a public hearing or at public meeting, by re-recording the original ordinance or a certified copy of the ordinance and attaching the correct legal description.

Section 6. If any provision or portion of this Ordinance is declared by any court of competent jurisdiction to be void, unconstitutional, or unenforceable, then all remaining provisions and portions of this Ordinance shall remain in full force and effect.

Section 7. All ordinances and parts of ordinances to the extent in conflict with this Ordinance are hereby repealed.

Section 8. This Ordinance shall become effective immediately upon passage by the City Commission of the City of Fruitland Park.

PASSED AND ORDAINED in regular session of the City Commission of the City of Fruitland Park, Lake County, Florida, this _____ day of _____, 2023.

Chris Cheshire, Mayor
City of Fruitland Park, Florida

(SEAL)

ATTEST:

Esther Coulson, MMC, City Clerk

Approved as to Form:

Anita Geraci-Carver, City Attorney

Mayor Cheshire _____ (Yes), _____ (No), _____ (Abstained), _____ (Absent)
Vice-Mayor DeGrave _____ (Yes), _____ (No), _____ (Abstained), _____ (Absent)
Commissioner Gunter _____ (Yes), _____ (No), _____ (Abstained), _____ (Absent)
Commissioner Bell _____ (Yes), _____ (No), _____ (Abstained), _____ (Absent)
Commissioner Mobilian _____ (Yes), _____ (No), _____ (Abstained), _____ (Absent)

Denied First Reading March 9, 2023
Passed Second Reading _____

EXHIBIT A
Legal Description

THE EAST 1/2 OF THE NORTHEAST 1/4 OF NORTHEAST 1/4, SECTION 16,
TOWNSHIP 19 SOUTH, RANGE 24 EAST, LAKE COUNTY, FLORIDA.
LESS THE SOUTH 50 FEET THEREOF.

ALSO DESCRIBED AS:

BEGIN AT THE NORTHEAST CORNER OF SECTION 16, TOWNSHIP 19 SOUTH,
RANGE 24 EAST, LAKE COUNTY, FLORIDA THENCE S 00°53'57" E, ALONG THE
EAST LINE OF THE NORTHEAST 1/4 OF NORTHEAST 1/4, A DISTANCE OF 1265.41
FEET; THENCE N 89°25'38" W, A DISTANCE OF 657.76 FEET, TO THE WEST LINE OF
THE EAST 1/2 OF THE NORTHEAST 1/4 OF NORTHEAST 1/4, THENCE N 00°55'00"
E, ALONG SAID WEST LINE, A DISTANCE OF 1266.62 FEET, TO THE NORTH LINE
OF THE NE 1/4 OF SAID SECTION 16; THENCE S 89°19'17" E, ALONG SAID NORTH
LINE, A DISTANCE OF 657.37' TO THE POINT OF BEGINNING.

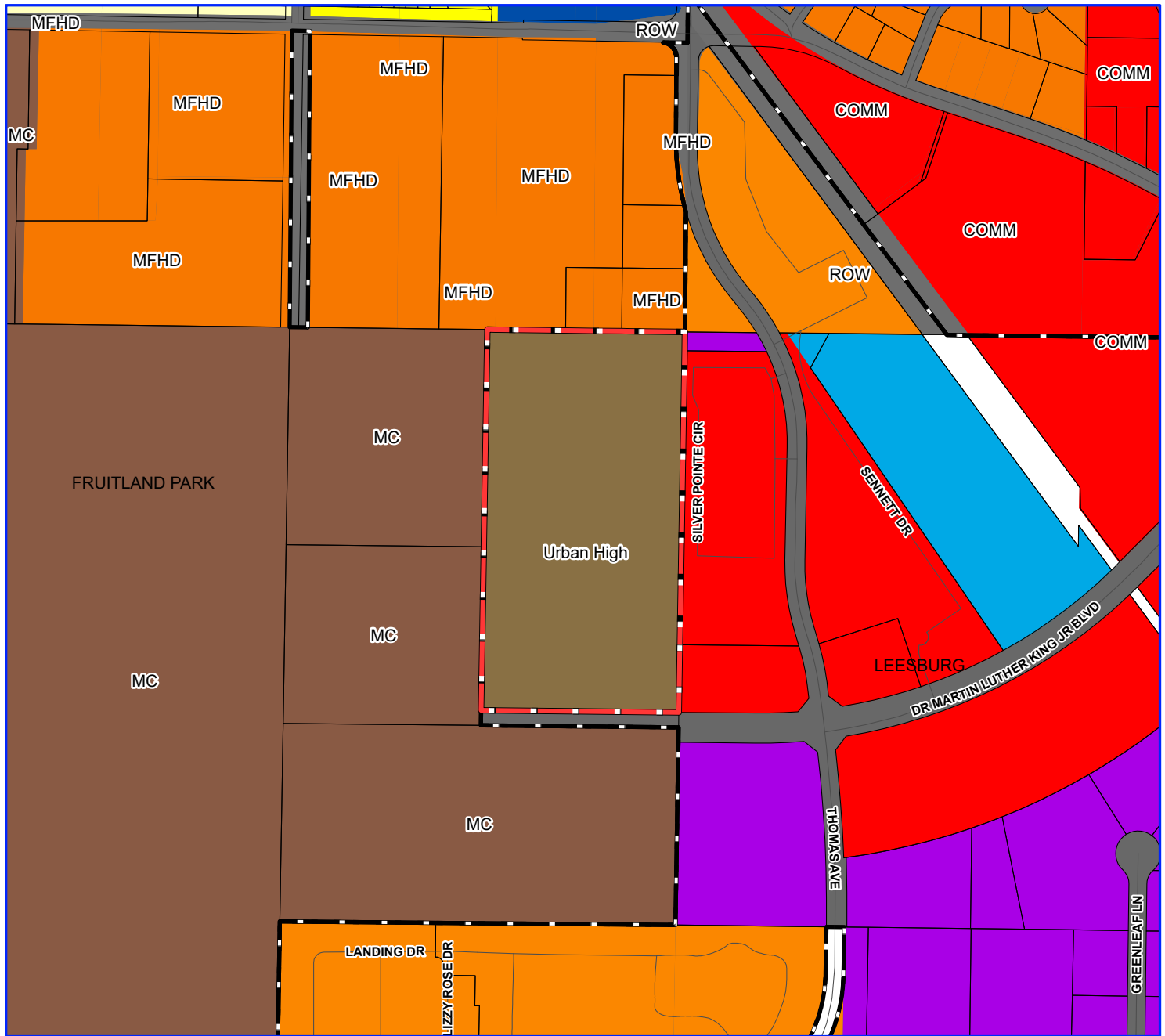

Legend

Site Boundary

City Limits

Lake County Future Land Use

Urban High Density

City of Fruitland Park Future Land Use

SFLD, Single Family Low Density

SFMD, Single Family Medium Density

MFHD, Multiple Family/High Density

COMM, Commercial

MC, Mixed Community

INST, Institutional

ROW, Transportation

City of Leesburg Future Land Use

RIGHT-OF-WAY

GENERAL COMMERCIAL

INSTITUTIONAL

INDUSTRIAL

HIGH DENSITY

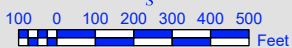

1 inch = 500 feet

**City of Fruitland Park
Park Square**
Lake County, Florida
Existing Future Land Use Map

Project: 398-22-10
File: Existing FLU
Name: Park Square
PM: Sherie Lindh
Date: December 7, 2022
Created By: J. Wilson



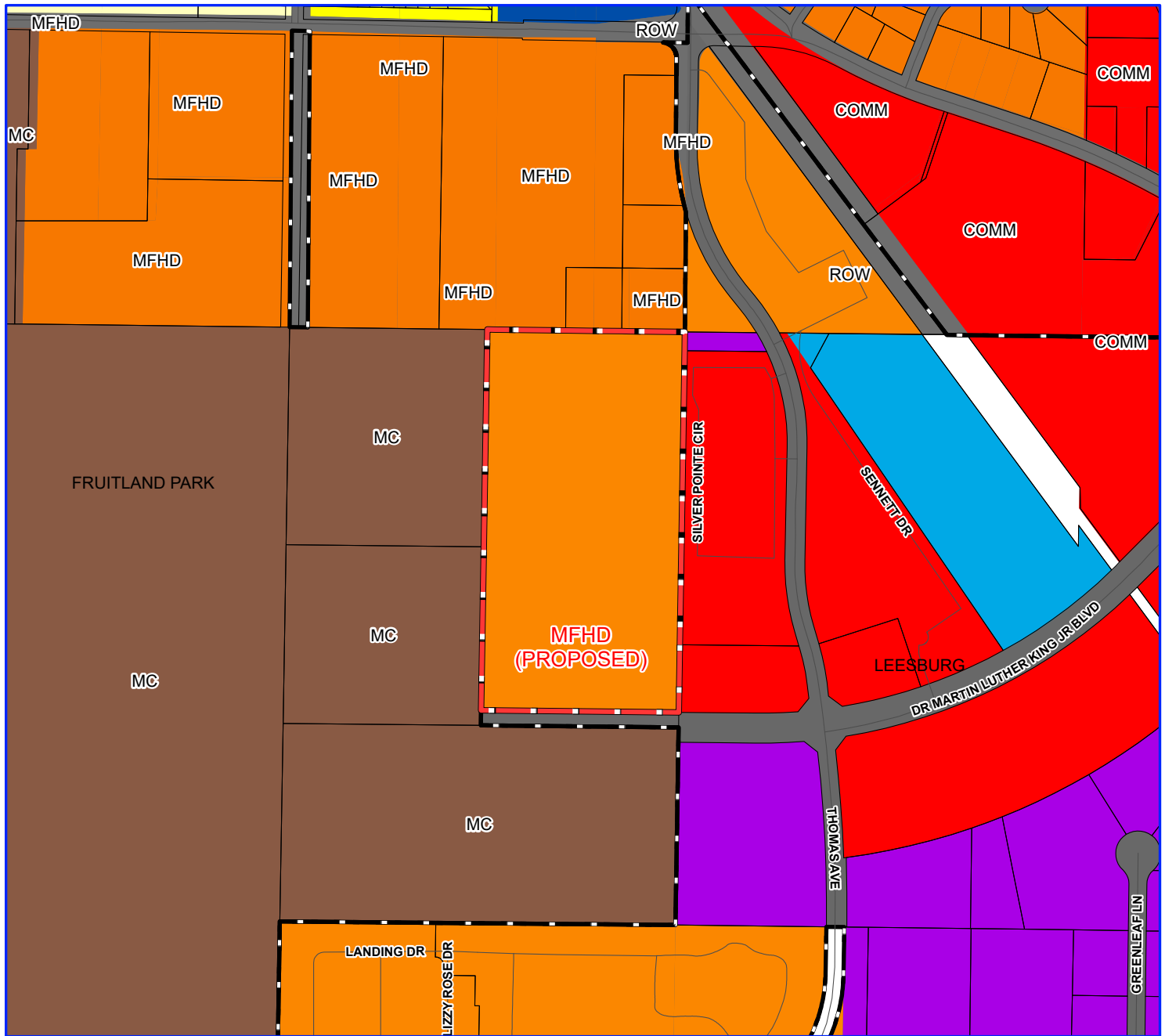

Legend

Site Boundary

City Limits

Lake County Future Land Use

Urban High Density

City of Fruitland Park Future Land Use

SFLD, Single Family Low Density

SFMD, Single Family Medium Density

MFHD, Multiple Family/High Density

COMM, Commercial

MC, Mixed Community

INST, Institutional

ROW, Transportation

City of Leesburg Future Land Use

RIGHT-OF-WAY

GENERAL COMMERCIAL

INSTITUTIONAL

INDUSTRIAL

HIGH DENSITY

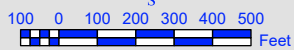

1 inch = 500 feet

**City of Fruitland Park
Park Square
Lake County, Florida
Proposed Future Land Use Map**

Project: 398-22-10
File: Proposed FLU
Name: Park Square
PM: Sherie Lindh
Date: December 7, 2022
Created By: J. Wilson



**CITY OF FRUITLAND PARK
STAFF REPORT BY LPG URBAN & REGIONAL PLANNERS, INC.**

ANNEXATION, SSCPA, AND REZONING

Owner: Kimaya, LLC

Applicant: Vishaal Gupta

General Location: Silver Pointe Circle/ Urick St/ Thomas Ave

Number of Acres: 19.10 ± acres

Existing Zoning: Agriculture (Lake County)

Proposed Zoning: R-10 (City of Fruitland Park)

Existing Land Use: Urban High (Lake County) (12 units/acre)

Proposed Land Use: Multi-Family Medium Density (10 units/acre)

Date: December 13, 2022

Description of Project

The applicant is requesting annexation, a small-scale comp plan amendment, and a rezoning to receive city services and develop a proposed subdivision including single family cottages, townhomes, and multi-family apartments.

	Surrounding Zoning	Surrounding Land Use
North	R-15	Multi-Family High Density (15 units/acre)
South	City of Leesburg – appears to be r/w	City of Leesburg – no land use designated
East	C-3	General Commercial (City of Leesburg)
West	MUPUD	Mixed Community (6 units/acre)

Assessment

Applications

Please be advised that the concurrency application indicates 304 units; however, the maximum # of units that potentially could be allowed is 191. Please revise application.

Annexation

The subject site is adjacent to the City limits along the northern and western property boundaries and is eligible for voluntary annexation. The proposed annexation would be considered infill development. The subject site is also within the City's Utility Service Area.

Rezoning

The subject property is currently zoned Agriculture in Lake County and the proposed City zoning is R-10 (minimum lot size for single family of 8,000 square feet with central sewer being utilized, and minimum lot size for multi-family of 6,000 square feet with central sewer). The proposed zoning is compatible with the adjacent lands. The property to the North is zoned R-15, and to the west the property is zoned MUPUD (6 units/acre). The property to the South is City of Leesburg (appears to be City of Leesburg right of way), and to the east the property is zoned C-3.

Small Scale Comp Plan Amendment

For comprehensive plan purposes a maximum development scenario was utilized.

Residential Needs Analysis – The housing element data and analysis indicates the City requires a minimum of 5,460 additional dwelling units to meet the projected need through 2035. The addition of 287 units will assist in meeting this need.

School Impact Analysis – The amendment will decrease the impacts to schools, as it is a decrease in density from 12 units/acre (228 units) to 10 units/acre (191 units). The decrease in school age children is from 65 students to 54 students; a decrease of 11 students. Please provide adequate school facilities determination from Lake County Schools.

Existing County Land Use Residential Units: 228 units

Proposed Development Residential Units: 191 units

The anticipated number of students generated by the existing land use is shown in Table 1.

**TABLE 1
STUDENTS GENERATED BASED ON EXISTING DEVELOPMENT**

Lake County Student Generation Rates	
Multi-Family	
Type	Student Multipliers per Dwelling Unit
High School	0.143
Middle School	0.063
Elementary School	0.077
Total	0.283

SCHOOL	SF Units	STUDENT GENERATION RATE	STUDENTS GENERATED	MF UNITS	STUDENT GENERATION RATE	STUDENTS GENERATED	GRAND TOTAL
ELEMENTARY	0	0.152	0	228	0.143	33	33
MIDDLE	0	0.074	0	228	0.063	14	14
HIGH	0	0.102	0	228	0.077	18	18
GRAND TOTAL							65

The anticipated number of students generated by the proposed land use is shown in Table 2.

SCHOOL	SF Units	STUDENT GENERATION RATE	STUDENTS GENERATED	MF UNITS	STUDENT GENERATION RATE	STUDENTS GENERATED	GRAND TOTAL
ELEMENTARY	0	0.152	0	191	0.143	27	27
MIDDLE	0	0.074	0	191	0.063	12	12
HIGH	0	0.102	0	191	0.077	15	15
GRAND TOTAL							54

Traffic Impact Analysis – The amendment will decrease traffic impacts as it is an decrease in density. The LOS for Dr Martin Luther King Jr. Blvd is “D”. Results of the trip analysis indicate that the proposed amendment will decrease the daily trips by 281 and reduce the PM Peak hour trips by 23. The proposed increase in traffic is considered de minimus.

TRIP GENERATION ANALYSIS

Proposed Land Use Program

Land Use	Size/Unit	ITE Code	Daily Trips	PM Peak Hour Trips	PM Trips Enter	PM Trips Exit
MF Residential	191 units	220	1,388	105	66	39
TOTAL GROSS TRIPS (PROPOSED)			1,388	105	66	39

Existing Land Use Program

Land Use	Size/Unit	ITE Code	Daily Trips	PM Peak Hour Trips	PM Trips Enter	PM Trips Exit
MF Residential	228 units	220	1,669	128	80	47
TOTAL GROSS TRIPS (EXISTING)			1,669	128	80	47

Net Difference (Proposed Net Generation Minus Existing Net Trip Generation)

Land Use	PM Peak Hour Trips	PM Trips Enter	PM Trips Exit
TOTAL NET TRIPS (PROPOSED – EXISTING)	-23	-14	-8

Solid Waste Impact Analysis – The LOS for solid waste is 2 collections per week pursuant to Public Facilities Policy 4-6.1. The City utilizes a private waste hauler through a franchise agreement. The amendment will not cause a deficiency in the LOS.

Utility Impact Analysis – The subject site is within the City of Fruitland Park Utility Service Area and central water is available. The LOS for water is 172 gallons per resident per day pursuant to Public Facilities Policy 4-10.1. The estimated population based on US Census data (estimated 2019) of 2.42 person per household is 462. The estimated water usage is 0.079.

The City owns, operates and maintains a central potable water treatment and distribution system. The permitted plant capacity is 2.879 MGD and the permitted consumptive use permit capacity is 1.22 MGD. The City has a current available capacity of .396 mgpd and an analysis was conducted of the proposed amendment based on land use and the City’s Level of Service (LOS) standards. The analysis concludes that the proposed amendment will not cause a deficiency and the City will have a remaining available capacity of 0.317 mgpd.

The City of Fruitland Park provides sanitary sewer. The City of Fruitland Park has an agreement with the Town of Lady Lake to treat sewage and the maximum capacity is 500,000 gallons per day (0.5 mgd). The City currently has an available capacity of 430,000 gallons per day (0.43 mgd). The LOS for sanitary sewer is 122 gallons per resident per day pursuant to Public Facilities Policy 4-2.1. The estimated population based on US Census data (estimated 2019) of 2.42 person per household is 462. The estimated sanitary sewer usage is 0.056 (mgd). The analysis concludes that the proposed amendment will not cause a deficiency and the City will have a remaining capacity of 0.374 (mgd).

Environmental Analysis – There are no wetlands or surface waters onsite. Formal surveys for the federally listed sand skink were completed in accordance with USFWS survey protocol in May 2022. A 4-week formal coverboard survey detected a total of forty-seven (47) coverboard with skink tracks within the project site on suitable habitat. The coverboard survey tracks detected determined that 7.43 acres of the subject property contains occupied sand skink habitat and if this area cannot be avoided then mitigation will be required from a USFWS approved Conservation Bank.

There were no known eagle nests observed on the property. A pedestrian survey of the subject property located potentially occupied gopher tortoise burrows. Prior to land clearing and/or construction it is advised that a 100% survey of all potentially suitable gopher tortoise habitat be performed. Prior to development, appropriate regulatory permits will be required.

Comprehensive Plan Compliance

The subject amendment is consistent with the following Comprehensive Plan policies, among others. The amendment will further the City’s goals in meeting projected housing demands through 2035.

- FLU Policy 1-1.1:** Adequate Residential Land Area.
- FLU Policy 1-1.2:** Density and Intensity Standards and Table 1-1 – Multi-Family Medium Density, 10 units/acre.
- FLU Policy 1-1.6:** Multiple-Family Medium Density.
- FLU Policy 1-2.1:** Promote Orderly, Compact Growth.

Recommendation

It is highly recommended that a conceptual plan be submitted with the rezoning to R-10. Please submit adequate schools determination or school concurrency reservation.

The Villages
DAILY SUN

Published Daily
 Lady Lake, Florida
 State of Florida
 County Of Lake

Before the undersigned authority personally appeared **Joseph Szabo**, who on oath says that she is Legal Ad Coordinator of the DAILY SUN, a daily newspaper published at Lady Lake in Lake County, Florida with circulation in Lake, Sumter and Marion Counties; that the attached copy of advertisement, being a Legal #1112190 in the matter of

NOTICE OF PUBLIC HEARING

was published in said newspaper in the issues of

FEBRUARY 17, 2023

Affiant further says that the said Daily Sun is a newspaper published at Lady Lake in said Lake County, Florida, and that the said newspaper has heretofore been continuously published in said Lake County, Florida each week and has been entered as second class mail matter at the post office in Lady Lake, in said Lake County, Florida, for a period of one year next preceding the first publication of the attached copy of advertisements; and affiant further says that he has neither paid nor promised any person, firm, or Corporation any discount, rebate, commission or refund for the purpose of securing this advertisement for Publication in the said newspaper.

(Handwritten Signature)

 (Signature Of Affiant)

Sworn to and subscribed before me this 21 day of February 2023.

(Handwritten Signature)

 Robin L. Baldeschwieler, Notary

Personally Known X or
 Production Identification _____
 Type of Identification Produced _____

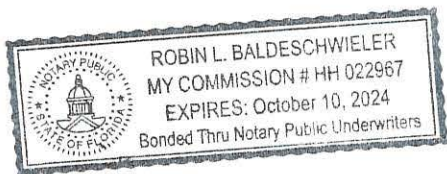

10 a.m.: Virginia Tech vs. Okla.St. (ESPNU)

12:30 p.m.: Indiana vs. Mississippi St. (SECN, Ch. 745)

1 p.m.: Duke vs. South Florida (ACCN)

1 p.m.: Arkansas vs. Florida St. (ESPNU)

4 p.m.: Virginia Tech vs. Nebraska (AGCN)

4 p.m.: Alabama vs. UCLA (ESPN2, Ch. 29)

Golf

5:30 a.m.: Asian Tour: International Series (GOLF, Ch. 49)

Noon: PGA Tour Champions: Chubb Classic (GOLF, Ch. 49)

4 p.m.: PGA Tour: Genesis Invitational (GOLF, Ch. 49)

NBA

7 p.m.: All-Star Celebrity Game (ESPN, Ch. 28)

9 p.m.: Jordan Rising Stars Game (TNT, Ch.27)

NHL

9 p.m.: Los Angeles at Anaheim (ESPN, Ch. 28)

Men's soccer

2:40 p.m.: Serie A: Napoli at Sassuolo (CBSSN)

8 p.m.: Liga MX: León at Juárez (FS2)

Tennis

7 a.m.: Delray Beach-ATP, Rotterdam-ATP, Buenos Aires-ATP Quarterfinals; Doha-WTA Semifinals (TENNIS)

NOTICE OF PUBLIC HEARING

ORDINANCE 2023 - 001

AN ORDINANCE OF THE CITY COMMISSION OF THE CITY OF FRUITLAND PARK, FLORIDA, AMENDING THE BOUNDARIES OF THE CITY OF FRUITLAND PARK FLORIDA, IN ACCORDANCE WITH THE PROCEDURE SET FORTH IN SECTION 171.044, FLORIDA STATUTES, TO INCLUDE WITHIN THE CITY LIMITS APPROXIMATELY 19.10 ± ACRES OF LAND GENERALLY LOCATED SOUTH OF URICK STREET AND WEST OF THOMAS AVENUE; DIRECTING THE CITY MANAGER TO PROVIDE CERTIFIED COPIES OF THIS ORDINANCE AFTER APPROVAL TO THE CLERK OF THE CIRCUIT COURT, THE LAKE COUNTY MANAGER AND THE DEPARTMENT OF STATE OF THE STATE OF FLORIDA; PROVIDING FOR SCRIVENER'S ERRORS, SEVERABILITY AND CONFLICTS; PROVIDING FOR AN EFFECTIVE DATE.

ORDINANCE 2023-002

AN ORDINANCE OF THE CITY COMMISSION OF THE CITY OF FRUITLAND PARK, FLORIDA, PROVIDING FOR A SMALL SCALE COMPREHENSIVE PLAN AMENDMENT BY AMENDING THE FUTURE LAND USE PLAN DESIGNATION FROM LAKE COUNTY URBAN HIGH DENSITY TO CITY MULTI-FAMILY MEDIUM DENSITY OF 19.10 +/- ACRES OF PROPERTY GENERALLY LOCATED SOUTH OF URICK STREET AND WEST OF THOMAS AVENUE; DIRECTING THE CITY MANAGER OR DESIGNEE TO TRANSMIT THE AMENDMENT TO THE APPROPRIATE GOVERNMENTAL AGENCIES PURSUANT TO CHAPTER 163, FLORIDA STATUTES; AUTHORIZING THE CITY MANAGER TO AMEND SAID COMPREHENSIVE PLAN; PROVIDING FOR SEVERABILITY, CONFLICTS AND SCRIVENER'S ERRORS; REPEALING ALL ORDINANCES IN CONFLICT HEREWITH; PROVIDING FOR AN EFFECTIVE DATE.

ORDINANCE 2023-003

AN ORDINANCE OF THE CITY COMMISSION OF THE CITY OF FRUITLAND PARK, FLORIDA, REZONING 19.10 +/- ACRES OF PROPERTY FROM LAKE COUNTY AGRICULTURE (A) TO CITY OF FRUITLAND PARK R-10 WITHIN THE CITY LIMITS OF FRUITLAND PARK; GENERALLY LOCATED SOUTH OF URICK STREET AND WEST OF THOMAS AVENUE; DIRECTING THE CITY MANAGER OR DESIGNEE TO HAVE AMENDED THE ZONING MAP OF THE CITY OF FRUITLAND PARK; PROVIDING FOR SEVERABILITY, CONFLICTS AND SCRIVENER'S ERRORS; REPEALING ALL ORDINANCES IN CONFLICT HEREWITH; PROVIDING FOR AN EFFECTIVE DATE

The proposed Ordinances will be considered at the following public meetings:

- Fruitland Park City Commission Meeting on March 9th, 2023 at 6:00 p.m.
- Fruitland Park Land Planning Agency Meeting on March 9th, 2023 at 6:15 p.m.
- Fruitland Park City Commission Meeting March 23rd, 2023 at 6:00 p.m.

The public meetings will be held in the Commission Chambers located at City Hall, 506 West Berckman Street, Fruitland Park FL 34731. These meetings are open to the public and hearings may be continued as determined by the commission from time to time to a time/date certain. The proposed Ordinances and metes and bounds legal description of property may be inspected by the public during normal working hours at City Hall. For further information call 352-360-6727. Interested parties may appear at the meetings and will be heard with respect to the proposed resolution.

A person who decides to appeal any decision made by any board, agency or council with respect to any matter considered at such meeting or hearing, will need a record of the proceedings. For such purposes, any such person may need to ensure that a verbatim record of the proceedings is made, which includes the testimony and evidence upon which the appeal is based (Florida Statutes, 286.0105). Persons with disabilities needing assistance to participate in any of these proceedings should contact Esther Coulson, City Clerk at (352) 360-6790 at least 48 hours before the date of the scheduled hearing.

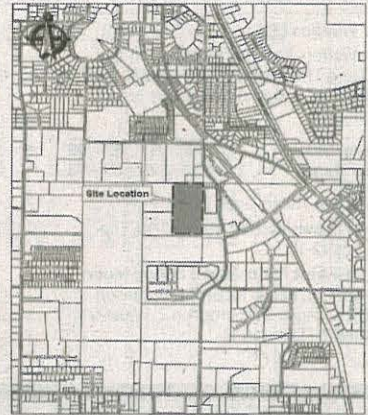

CITY OF FRUITLAND PARK
AGENDA ITEM SUMMARY SHEET
Item Number: 5g

ITEM TITLE: Second Reading and Public Hearing - Ordinance 2023-002 SSCPA - South of Urick Street and West of Thomas Avenue - Petitioner: Kimaya, LLC

MEETING DATE: Thursday, March 23, 2023

DATE SUBMITTED: Friday, February 24, 2023

SUBMITTED BY: City Attorney/City Manager/Community Development

BRIEF NARRATIVE: Ordinance 2023-002 small-scale comprehensive plan amendment to receive city services and develop a proposed subdivision including single family cottages, townhomes, and multi-family apartments.

FUNDS BUDGETED: None

ATTACHMENTS: Proposed Ordinance 2023-002, legal description and maps (see Item 7.(b) for staff report and advertising affidavit).

RECOMMENDATION: It is highly recommended that a conceptual plan be submitted with the rezoning to R-10 and that adequate schools' determination or school concurrency reservation be submitted. The Planning and Zoning Board recommended approval at its January 19, 2023 meeting. (First reading was held on March 9, 2023.)

ACTION:

ORDINANCE 2023-002

AN ORDINANCE OF THE CITY COMMISSION OF THE CITY OF FRUITLAND PARK, FLORIDA, PROVIDING FOR A SMALL SCALE COMPREHENSIVE PLAN AMENDMENT BY AMENDING THE FUTURE LAND USE PLAN DESIGNATION FROM LAKE COUNTY URBAN HIGH DENSITY TO CITY MULTI-FAMILY MEDIUM DENSITY OF 19.10 +/- ACRES OF PROPERTY GENERALLY LOCATED SOUTH OF URICK STREET AND WEST OF THOMAS AVENUE; DIRECTING THE CITY MANAGER OR DESIGNEE TO TRANSMIT THE AMENDMENT TO THE APPROPRIATE GOVERNMENTAL AGENCIES PURSUANT TO CHAPTER 163, FLORIDA STATUTES; AUTHORIZING THE CITY MANAGER TO AMEND SAID COMPREHENSIVE PLAN; PROVIDING FOR SEVERABILITY, CONFLICTS AND SCRIVENER'S ERRORS; REPEALING ALL ORDINANCES IN CONFLICT HERewith; PROVIDING FOR AN EFFECTIVE DATE.

WHEREAS, a petition has been received from Vishaal Gupta as applicant, on behalf of Kimaya, LLC as Owner, requesting that real property within the city limits of the City of Fruitland Park be assigned a land use designation of "Multi-Family Medium Density" under the Comprehensive Plan for the City of Fruitland Park; and

WHEREAS, the required notice of the proposed small scale comprehensive plan amendment has been properly published as required by Chapter 163, Florida Statutes; and

WHEREAS, the Planning and Zoning Commission of the City of Fruitland Park and the Local Planning Agency for the City of Fruitland Park have reviewed the proposed amendment to the Comprehensive Plan and have made recommendations to the City Commission of the City of Fruitland Park.

NOW, THEREFORE, BE IT ORDAINED BY THE CITY COMMISSION OF FRUITLAND PARK, FLORIDA, AS FOLLOWS:

Section 1: The following described property consisting of approximately 19.10 ± acres generally located south of Urick Street and west of Thomas Avenue as described and depicted as set forth on Exhibit "A" shall be assigned a land use designation of Multi-Family Medium Density under the City of Fruitland Park Comprehensive Plan as depicted on the map attached hereto as Exhibit "B" and incorporated herein by reference.

Section 2: A copy of said Land Use Plan Amendment is filed in the office of the City Manager of the City of Fruitland Park as a matter of permanent record of the City, matters and contents therein are made a part of this ordinance by reference as fully and completely as if set forth herein, and such copy shall remain on file in said office available for public inspection.

Section 3: Direction to the City Manager.

Upon the Effective Date of this ordinance, the City Manager is hereby authorized to amend the comprehensive plan and future land-use map as identified herein after compliance with F.S. 163.3187 and F.S. 163.3184(11).

Section 4: Severability.

If any provision or portion of this Ordinance is declared by any court of competent jurisdiction to be void, unconstitutional, or unenforceable, then all remaining provisions and portions of this Ordinance shall remain in full force and effect.

Section 5: All ordinances or parts of ordinances in conflict herewith are hereby repealed.

Section 6: Scrivener's Errors.

Scrivener's errors in the legal description may be corrected without a public hearing or at public meeting, by re-recording the original ordinance or a certified copy of the ordinance and attaching the correct legal description.

Section 7: Adoption

After adoption, a copy hereof shall be forwarded to the Department of Economic Opportunity.

Section 8: This Ordinance shall become effective 31 days after its adoption by the City Commission. If this Ordinance is challenged within 30 days after its adoption, it may not become effective until the state land planning agency or Administrative Commission, respectively, issues a final order determining that this Ordinance is in compliance. No development permits or land uses dependent on this amendment may be issued or commence before it has become effective.

PASSED AND ORDAINED in regular session of the City Commission of the City of Fruitland Park, Lake County, Florida, this _____ day of _____, 2023.

Chris Cheshire, Mayor
City of Fruitland Park, Florida

ATTEST:

Approved as to Form:

Esther Coulson, MMC, City Clerk

Anita Geraci-Carver, City Attorney

Mayor Cheshire	_____	(Yes),	_____	(No),	_____	(Abstained),	_____	(Absent)
Vice-Mayor DeGrave	_____	(Yes),	_____	(No),	_____	(Abstained),	_____	(Absent)
Commissioner Gunter	_____	(Yes),	_____	(No),	_____	(Abstained),	_____	(Absent)
Commissioner Bell	_____	(Yes),	_____	(No),	_____	(Abstained),	_____	(Absent)
Commissioner Mobilian	_____	(Yes),	_____	(No),	_____	(Abstained),	_____	(Absent)

Denied First Reading March 9, 2023
Passed Second Reading _____
(SEAL)

“EXHIBIT A”

THE EAST 1/2 OF THE NORTHEAST 1/4 OF NORTHEAST 1/4, SECTION 16,
TOWNSHIP 19 SOUTH, RANGE 24 EAST, LAKE COUNTY, FLORIDA.
LESS THE SOUTH 50 FEET THEREOF.

ALSO DESCRIBED AS:

BEGIN AT THE NORTHEAST CORNER OF SECTION 16, TOWNSHIP 19 SOUTH,
RANGE 24 EAST, LAKE COUNTY, FLORIDA THENCE S 00°53'57" E, ALONG THE
EAST LINE OF THE NORTHEAST 1/4 OF NORTHEAST 1/4, A DISTANCE OF 1265.41
FEET; THENCE N 89°25'38" W, A DISTANCE OF 657.76 FEET, TO THE WEST LINE OF
THE EAST 1/2 OF THE NORTHEAST 1/4 OF NORTHEAST 1/4, THENCE N 00°55'00"
E, ALONG SAID WEST LINE, A DISTANCE OF 1266.62 FEET, TO THE NORTH LINE
OF THE NE 1/4 OF SAID SECTION 16; THENCE S 89°19'17" E, ALONG SAID NORTH
LINE, A DISTANCE OF 657.37' TO THE POINT OF BEGINNING.

EXHIBIT B

CITY OF FRUITLAND PARK
AGENDA ITEM SUMMARY SHEET
Item Number: 5h

ITEM TITLE: Second Reading and Quasi-Judicial Public Hearing - Ordinance 2023-003 Rezoning - South of Urick Street and West of Thomas Avenue - Petitioner: Kimaya, LLC

MEETING DATE: Thursday, March 23, 2023

DATE SUBMITTED: Friday, February 24, 2023

SUBMITTED BY: City Attorney/City Manager/Community Development

BRIEF NARRATIVE: Ordinance 2023-003 Rezoning to receive city services and develop a proposed subdivision including single family cottages, townhomes, and multi-family apartments.

FUNDS BUDGETED: None

ATTACHMENTS: Proposed Ordinance 2023-003, legal description, and maps and ex-parte communication to individual city commission members (same emails to the mayor and Item 7.(b) for staff report and advertising affidavit).

RECOMMENDATION: It is highly recommended that a conceptual plan be submitted with the rezoning to R-10 and that adequate schools' determination or school concurrency reservation be submitted. The Planning and Zoning Board recommended approval at its January 19, 2023 meeting. (First reading was held on March9, 2023)

ACTION:

ORDINANCE 2023-003

AN ORDINANCE OF THE CITY COMMISSION OF THE CITY OF FRUITLAND PARK, FLORIDA, REZONING 19.10 +/- ACRES OF PROPERTY FROM LAKE COUNTY AGRICULTURE (A) TO CITY OF FRUITLAND PARK R-10 WITHIN THE CITY LIMITS OF FRUITLAND PARK; GENERALLY LOCATED SOUTH OF URICK STREET AND WEST OF THOMAS AVENUE; DIRECTING THE CITY MANAGER OR DESIGNEE TO HAVE AMENDED THE ZONING MAP OF THE CITY OF FRUITLAND PARK; PROVIDING FOR SEVERABILITY, CONFLICTS AND SCRIVENER'S ERRORS; REPEALING ALL ORDINANCES IN CONFLICT HERewith; PROVIDING FOR AN EFFECTIVE DATE.

WHEREAS, a petition has been received from Vishaal Gupta as applicant, on behalf of Kimaya, LLC as Owner, requesting that real property within the city limits of the City of Fruitland Park be rezoned from Lake County A to City Multi-Family Medium Density Residential (R-10) within the City limits of Fruitland Park; and

WHEREAS, the petition bears the signature of all applicable parties; and

WHEREAS, the required notice of the proposed zoning has been properly published; and

WHEREAS, the City Commission reviewed said petition, the recommendations of the Planning and Zoning Board, staff report and any comments, favorable or unfavorable, from the public and surrounding property owners at a public hearing duly advertised;

NOW, THEREFORE, BE IT ORDAINED BY THE CITY COMMISSION OF FRUITLAND PARK, FLORIDA, AS FOLLOWS:

Section 1: The following described property consisting of approximately 19.10 ± acres generally located South of Urick Street and west of Thomas Avenue as described on Exhibit "A" and depicted as set forth on Exhibit "B" shall hereafter be designated as R-10 "Multi-Family Medium Density Residential" as defined in the Fruitland Park Land Development Regulations.

Section 2: That the City Manager, or designee, is hereby directed to have amended, altered, and implemented the official zoning maps of the City of Fruitland Park, Florida to include said designation consistent with this Ordinance.

Section 3. Severability. If any provision or portion of this Ordinance is declared by any court of competent jurisdiction to be void, unconstitutional, or unenforceable, then all remaining provisions and portions of this Ordinance shall remain in full force and effect.

Section 4. Scrivener's Errors. Scrivener's errors in the legal description may be corrected without a public hearing or at public meeting, by re-recording the original ordinance or a certified copy of the ordinance and attaching the correct legal description.

Section 5. Conflict. That all ordinances or parts of ordinances in conflict herewith are hereby repealed.

Section 6. This Ordinance shall become effective immediately upon passage by the City Commission of the City of Fruitland Park.

PASSED AND ORDAINED in regular session of the City Commission of the City of Fruitland Park, Lake County, Florida, this _____ day of _____, 2023.

Chris Cheshire, Mayor
City of Fruitland Park, Florida

ATTEST:

Approved as to Form:

Esther Coulson, MMC, City Clerk

Anita Geraci-Carver, City Attorney

Mayor Cheshire	_____ (Yes), _____ (No), _____ (Abstained), _____ (Absent)
Vice-Mayor Gunter	_____ (Yes), _____ (No), _____ (Abstained), _____ (Absent)
Commissioner Bell	_____ (Yes), _____ (No), _____ (Abstained), _____ (Absent)
Commissioner DeGrave	_____ (Yes), _____ (No), _____ (Abstained), _____ (Absent)
Commissioner Mobilian	_____ (Yes), _____ (No), _____ (Abstained), _____ (Absent)

Passed First Reading _____
Passed Second Reading _____
(SEAL)

“EXHIBIT A”

THE EAST 1/2 OF THE NORTHEAST 1/4 OF NORTHEAST 1/4, SECTION 16,
TOWNSHIP 19 SOUTH, RANGE 24 EAST, LAKE COUNTY, FLORIDA.
LESS THE SOUTH 50 FEET THEREOF.

ALSO DESCRIBED AS:

BEGIN AT THE NORTHEAST CORNER OF SECTION 16, TOWNSHIP 19 SOUTH,
RANGE 24 EAST, LAKE COUNTY, FLORIDA THENCE S 00°53'57" E, ALONG THE
EAST LINE OF THE NORTHEAST 1/4 OF NORTHEAST 1/4, A DISTANCE OF 1265.41
FEET; THENCE N 89°25'38" W, A DISTANCE OF 657.76 FEET, TO THE WEST LINE OF
THE EAST 1/ 2 OF THE NORTHEAST 1/4 OF NORTHEAST 1/4, THENCE N 00°55'00"
E, ALONG SAID WEST LINE, A DISTANCE OF 1266.62 FEET, TO THE NORTH LINE
OF THE NE 1/4 OF SAID SECTION 16; THENCE S 89°19'17" E, ALONG SAID NORTH
LINE, A DISTANCE OF 657.37' TO THE POINT OF BEGINNING.

EXHIBIT B

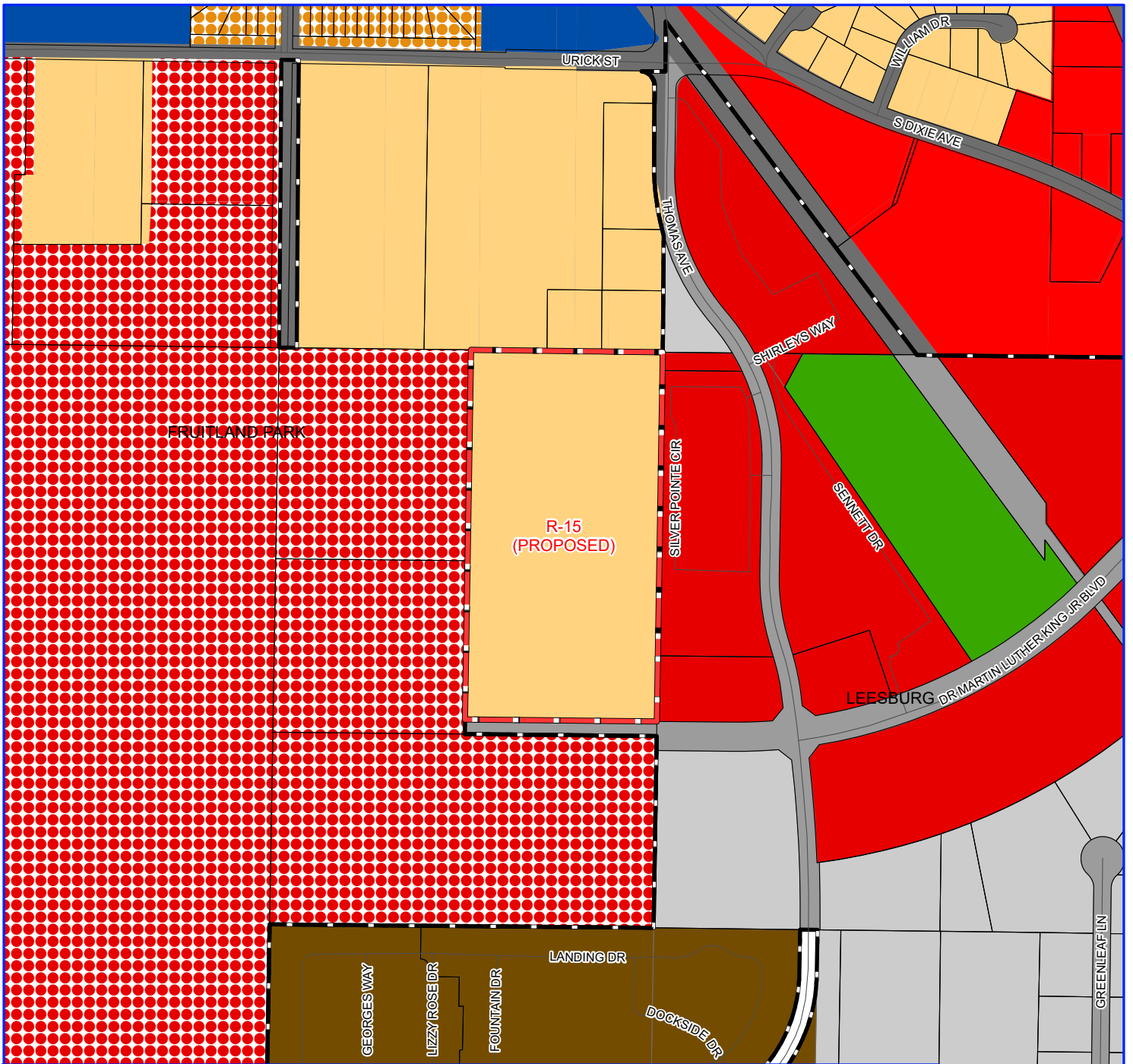

Legend

Site Boundary

City Limits

Lake County Zoning

Agriculture

City of Fruitland Park Zoning

R-15, Multi-Family Residential - High Density

C-2, General Commercial

PUD, Planned Unit Development

CPUD, Commercial Planned Unit Development District

PFD, Public Facilities District

ROW, Right-of-Way

City of Leesburg Zoning

C-3

M-1

P

R-3

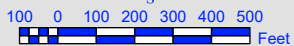

1 inch = 500 feet

**City of Fruitland Park
Park Square
Lake County, Florida
Proposed Zoning Map**

Project: 398-22-10
File: Proposed Zoning
Name: Park Square
PM: Sherie Lindh
Date: December 7, 2022
Created By: J. Wilson



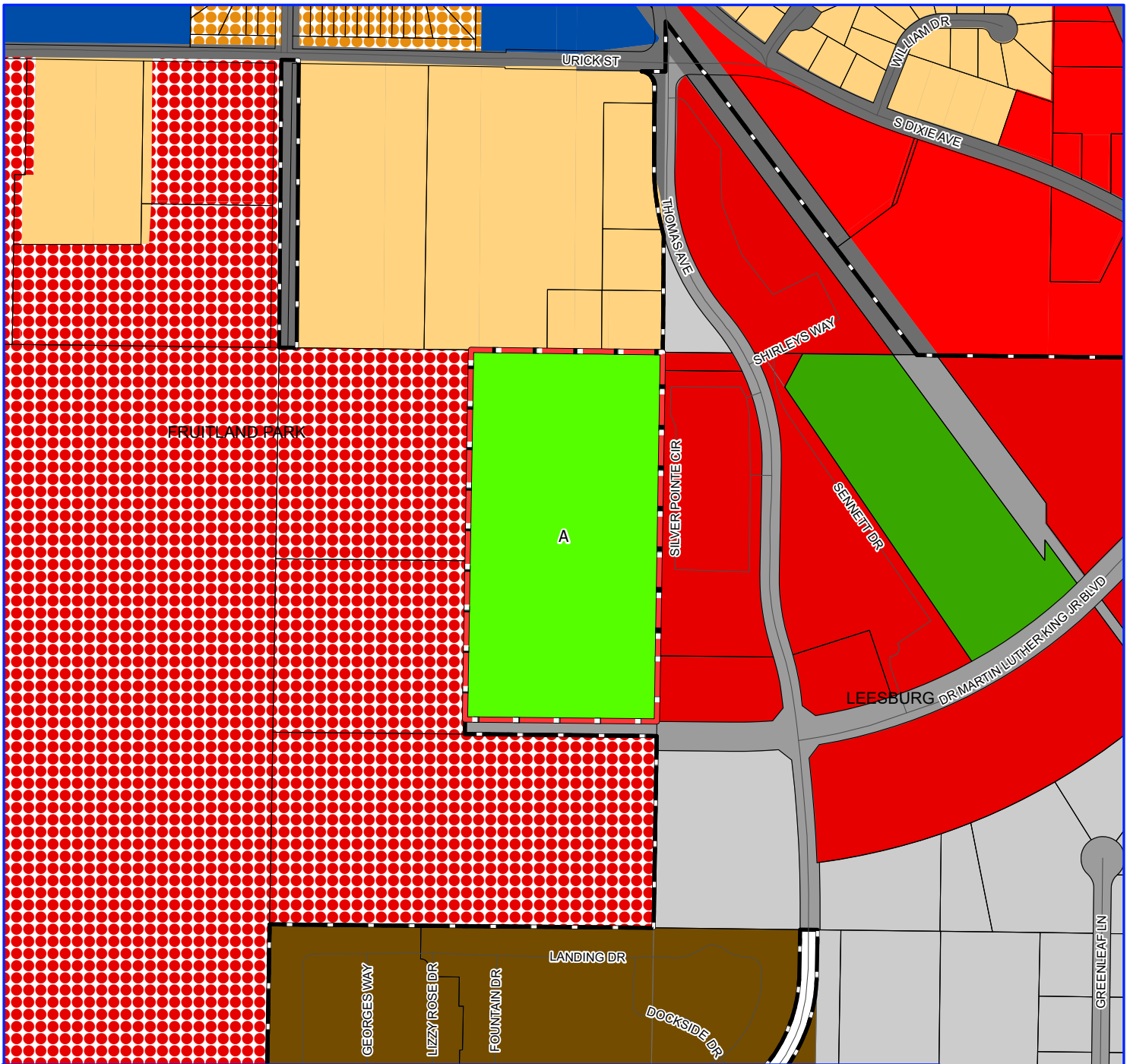

Legend

Site Boundary

City Limits

Lake County Zoning

Agriculture

City of Fruitland Park Zoning

R-15, Multi-Family Residential - High Density

C-2, General Commercial

PUD, Planned Unit Development

CPUD, Commercial Planned Unit Development District

PFD, Public Facilities District

ROW, Right-of-Way

City of Leesburg Zoning

C-3

M-1

P

R-3

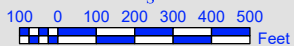

1 inch = 500 feet

**City of Fruitland Park
Park Square
Lake County, Florida
Existing Zoning Map**

Project: 398-22-10
File: Existing Zoning
Name: Park Square
PM: Sherie Lindh
Date: December 7, 2022
Created By: J. Wilson



1:\47000\4773\Complete\Half\TPA\Temple New Layout.dwg
3/17/2023 11:07:58 AM Joe_Jennifer HALFF.TPA.Site.ctb

SITE DATA	
ACREAGE:	19.11 AC (832,412 SF)
BUILD FOR RENT	566,256 SF

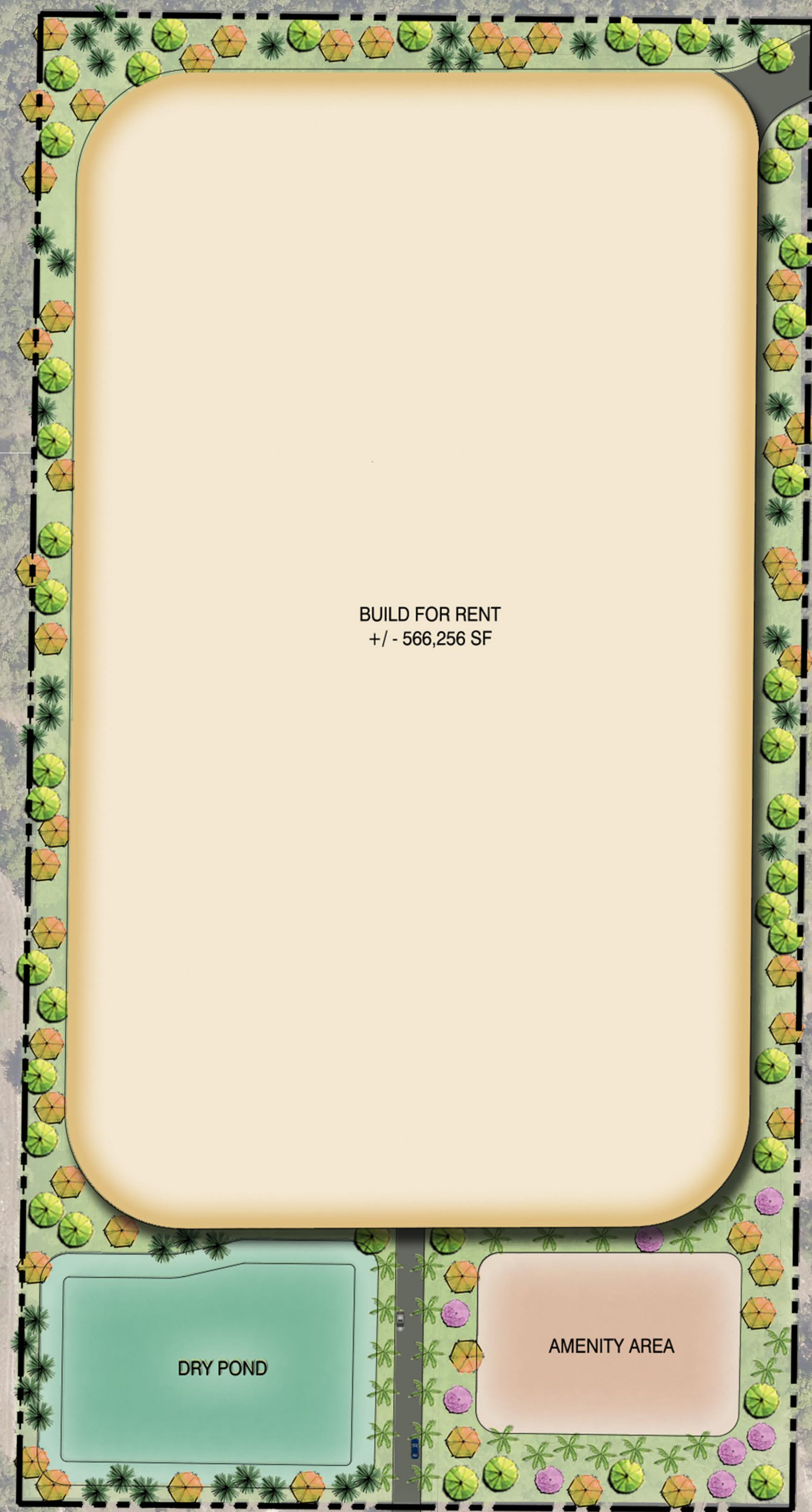

THOMAS AVE

KIMAYA PROJECT

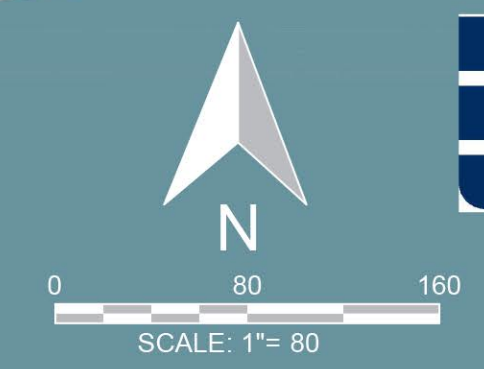

1000 n. ashley drive
suite 900 tampa, fl 33602
www.halff.com
813.6203.4500

From: [Christopher Cheshire](#)
To: [Esther Coulson](#); [Gary La Venia](#)
Subject: Fwd: Project for Feb. 9 Meeting
Date: Wednesday, March 15, 2023 7:02:25 AM
Attachments: [apartment pictures.pdf](#)
[ATT00001.htm](#)
[Annexation Aerial.pdf](#)
[ATT00002.htm](#)
[01.26.23. regular agenda Staff Report.pdf](#)
[ATT00003.htm](#)

Sent from my iPad

Begin forwarded message:

From: "Opsahl, Logan" <Logan.Opsahl@lowndes-law.com>
To: "Christopher Cheshire" <ccheshire@fruitlandpark.org>
Subject: RE: Project for Feb. 9 Meeting

Good Afternoon Mayor Cheshire,

I hope your week is going well. I understand this project has been placed on the March 9th City Commission Agenda. I would appreciate the opportunity to meet with you to discuss this project and address any questions you might have. Do you have any availability prior to the March 9th meeting to discuss?

I appreciate any time you have to devote to this.

Have a great evening,
Logan

Logan Opsahl

Associate

215 N. Eola Dr. | Orlando, FL 32801

D: 407.418.6237 | **P:** 407.843.4600 | **Ext:** 1237

[Email](#) | [Website](#) | [Bio](#) | [vCard](#)



LOCAL ROOTS. BROAD REACH. SM

From: Opsahl, Logan
Sent: Wednesday, February 8, 2023 2:10 PM
To: ccheshire@fruitlandpark.org

Subject: Project for Feb. 9 Meeting

Mayor Cheshire,

I wanted to provide some additional information about the project coming before the City Commission this Thursday.

Our law firm represents Kimaya, LLC for its request for annexation, small-scale comp plan amendment and rezoning on the approximately 19.10 acres south of Urick Street and west of Thomas Avenue. The Property is the easterly adjoining parcel to the approved Mixed-Use PUD, which is approved for up to 700 detached single-family residential units, assisted living facilities up to 220 beds, nursing home use, commercial uses, restaurants, banks, recreation and sports facilities. The parcel immediately to the north of the Property, and within the City of Fruitland Park, is zoned R-15 and entitled for Multi-Family High Density development of up to 15 units/acre.

The Property is currently situated within unincorporated Lake County and is entirely surrounded by the City of Fruitland Park to the North and West and City of Leesburg to the South and East. Following a successful annexation into the City, the Applicant is also requesting a rezoning from (County) Agriculture to (City) R-10 and a FLU designation change from (County) Urban High to (City) Multi-Family Medium Density. Following discussion with City Staff, the Applicant revised its request from 15 units/acre to 10 units/acre. It is worth noting that the Property's current FLU designation allows for up to 12 units/acre. The applicant's requested FLU designation of (City) Multi-Family Medium Density is a downzoning from its current existing and potential densities.

Annexation of the Property into the City will allow the Applicant to assemble adjoining parcels for a unified, continuous development that will allow for cohesive site circulation, buffering, setbacks, landscaping and other design capabilities in accordance with the specific performance standards of the City's Land Development Code.

The Applicant seeks to develop the Property with a market-rate multi-family product that will service the growth in the area and provide for a range of housing opportunities. Considering recent approvals in the area, the City has specifically contemplated this area for future development of urban-intensity growth. The Intended Use is a Class-A, three-story, multi-family development with market-leading amenities including a club house, pool, lounges, golf simulator, game room, fitness center and yoga room.

City Staff has concluded that the project will assist in meeting the projected housing

needs of the City as outlined in the housing element of the Comprehensive Plan. Importantly, City Staff has also concluded that the SSCPA will decrease the impacts to schools and traffic while not causing deficiencies to the city utilities readily-available to the Property.

For ease of reference, I have attached the Staff Report and conceptual renderings of similar projects. As you will note, the Staff Report concludes that there are ample capacities of all necessary urban services, the proposed land use change is compatible with significant growth in the area, surrounding developments and provide for additional tax base while meeting the projected residential housing needs of the City.

Please let me know if you have any questions. Thank you for your consideration!

Logan

Logan Opsahl

Associate

215 N. Eola Dr. | Orlando, FL 32801

D: 407.418.6237 | **P:** 407.843.4600 | **Ext:** 1237

[Email](#) | [Website](#) | [Bio](#) | [vCard](#)



LOCAL ROOTS. BROAD REACH. SM

Notice of Confidentiality: This e-mail communication and the attachment(s) hereto, if any, are intended solely for the information and use of the addressee(s) identified above and may contain information which is legally privileged from disclosure and/or otherwise confidential. If a recipient of this e-mail communication is not an addressee (or an authorized representative of an addressee), such recipient is hereby advised that any review, disclosure, reproduction, re-transmission or other dissemination or use of this e-mail communication (or any information contained herein) is strictly prohibited. If you are not an addressee and have received this e-mail communication in error, please advise the sender of that circumstance either by reply e-mail or by telephone at (800) 356-6818, immediately delete this e-mail communication from any computer and destroy all physical copies of same.

Replies Filtered: Any incoming reply to this e-mail communication or other e-mail communication to us will be electronically filtered for "spam" and/or "viruses." That filtering process may result in such reply or other e-mail communications to us being quarantined (i.e., potentially not received at our site at all) and/or delayed in reaching us. For that reason, we cannot guarantee that we will receive your reply or other e-mail communications to us and/or that we will receive the same in a timely manner. Accordingly, you should consider sending communications to us which are particularly important or time-sensitive by means other than e-mail.

[v4.30]

**CITY OF FRUITLAND PARK
AGENDA ITEM SUMMARY SHEET
Item Number: 6a**

ITEM TITLE: CITY MANAGER'S REPORT

MEETING DATE: Thursday, March 23, 2023

DATE SUBMITTED: Thursday, March 17, 2023

SUBMITTED BY: City Manager

BRIEF NARRATIVE: City Manager's Report

Economic Development Status Update

FUNDS BUDGETED: None

ATTACHMENTS:

RECOMMENDATION:

ACTION: None

**CITY OF FRUITLAND PARK
AGENDA ITEM SUMMARY SHEET
Item Number: 7**

ITEM TITLE: Public Comments

MEETING DATE: Thursday, March 23, 2023

DATE SUBMITTED: Friday, March 10, 2023

SUBMITTED BY: City Clerk

BRIEF NARRATIVE: **Item Description:** This section is reserved for members of the public to bring up matters of concern or opportunities for praise. Action may not be taken by the city commission at this meeting; however, questions may be answered by staff or issues may be referred for appropriate staff action.

Note: Pursuant to F.S. 286.0114 and the City of Fruitland Park's Public Participation Policy adopted by Resolution 2013-023, members of the public shall be given a reasonable opportunity to be heard on propositions before the city commission. Accordingly, comments, questions, and concerns regarding items listed on this agenda shall be received at the time the City Commission addresses such items during this meeting. Pursuant to Resolution 2013-023, public comments are limited to three minutes.

FUNDS REQUIRED: None

ATTACHMENTS:

RECOMMENDATION: None

ACTION: None